

LEPCOS (North-West Laboratory)

http://ferrite.ru Tel/fax +7-812-369-11-54
St-Petesburg, Russia

REVISIONS

REV	SYM	DRAFTER	CHECKER	DATE
△		T.S.LII	W.H.HSU	06/12/01
△		T.S.LII	W.H.HSU	11/01/04
△				

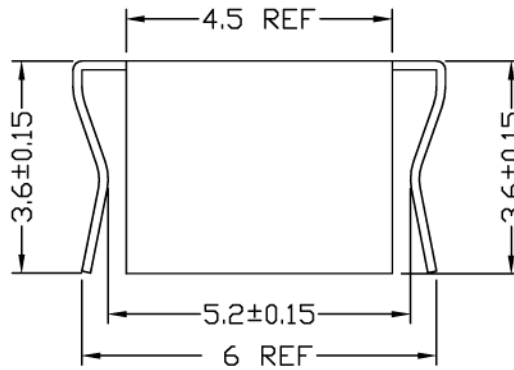
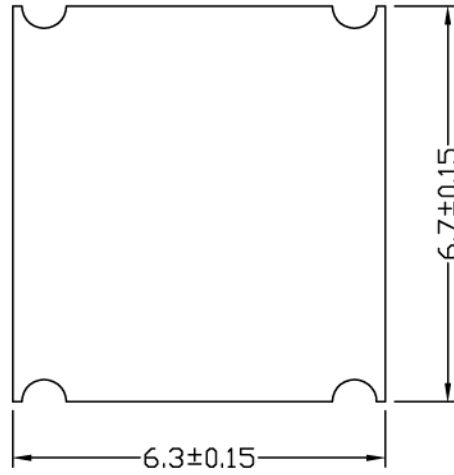

T=0.15

PART NO.	EP5-SMD-CLIP			
DWG NO.	MATERIAL (BOBBIN)	PLATING		BUYER 'S PART NO.
TBI-403-01011.1	SUS 301	NO		

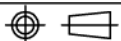

TOLERANCE: .X±0.15 .XX±0.10 .XXX±0.05

UNIT : m / m

SCALE 8 : 1

- Finish:
1. Immersion gold on terminal : Thickness gold 0.075 μm (3 μ inches) min, Base nickel 0.625 μm (25 μ inches) min.
 2. Immersion Sn on terminal : Terminal: Sn plating, 100, 5 μm (200 μ inches) min , Base nickel 0.625 μm (25 μ inches) min.
 3. Coplanarity deviation: 0.10 mm (0.004 inches)max.

REV 2