



Ferrites and accessories

RM 14, RM 14 LP
Cores and accessories

Series/Type: **B65887, B65888**
Date: September 2006

RM 14

Core

B65887

- To IEC 62317-4
- Optimized core cross section and increased thickness of base for power applications
- Without center hole
- Delivery mode: sets

Magnetic characteristics (per set)

$\Sigma l/A = 0.35 \text{ mm}^{-1}$
 $l_e = 70 \text{ mm}$
 $A_e = 200 \text{ mm}^2$
 $A_{min} = 170 \text{ mm}^2$
 $V_e = 14000 \text{ mm}^3$

Approx. weight 74 g/set

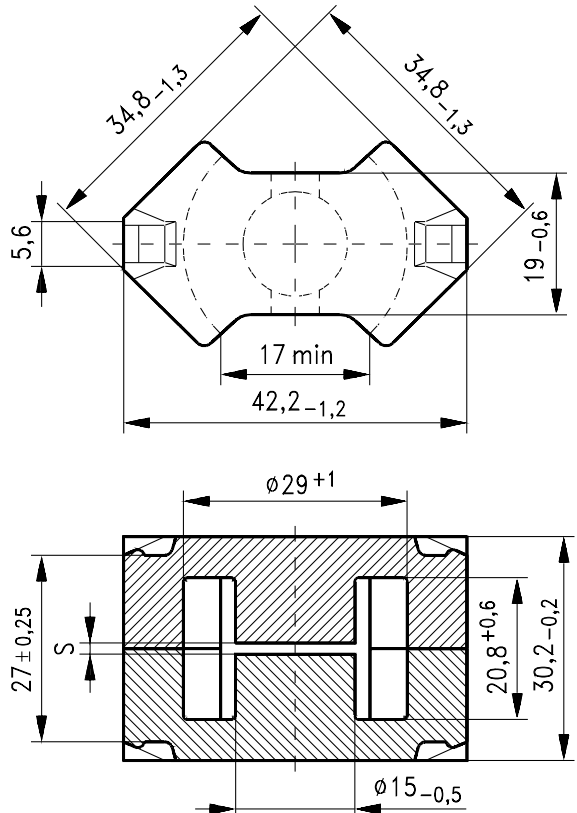

FRM0179-L

Gapped

Material	A_L value nH	s approx. mm	μ_e	Ordering code -E without center hole
N41	160 ±3%	1.90	45	B65887E0160A041
	250 ±3%	1.00	70	B65887E0250A041
	400 ±3%	0.50	111	B65887E0400A041
	1000 ±5%	0.15	279	B65887E1000J041

Ungapped

Material	A_L value nH	μ_e	P_V W/set	Ordering code -E without center hole
N49	3900 +30/-20%	1090	< 2.37 (50 mT, 500 kHz, 100 °C)	B65887E0000R049
N87	6000 +30/-20%	1670	< 7.40 (200 mT, 100 kHz, 100 °C)	B65887E0000R087
N97	6000 +30/-20%	1670	< 5.60 (200 mT, 100 kHz, 100 °C)	B65887E0000R097
N41	6800 +30/-20%	1890	< 2.52 (200 mT, 25 kHz, 100 °C)	B65887E0000R041

Coil former

Material: GFR thermosetting plastic (UL 94 V-0, insulation class to IEC 60085:
 H \triangleq max. operating temperature 180 °C), color code black
 Sumikon PM 9630® [E41429 (M)], SUMITOMO BAKELITE CO LTD

Solderability: to IEC 60068-2-20, test Ta, method 1 (aging 3): 235 °C, 2 s

Resistance to soldering heat: to IEC 60068-2-20, test Tb, method 1B: 350 °C, 3.5 s

Winding: see Data Book 2007, chapter "Processing notes, 2.1"

Squared pins.

For matching clamp and insulating washer see page 5.

Sections	A _N mm ²	l _N mm	A _R value μΩ	Pins	Ordering code
1	107	71.5	23	10 12	B65888N1010D001 B65888N1012D001

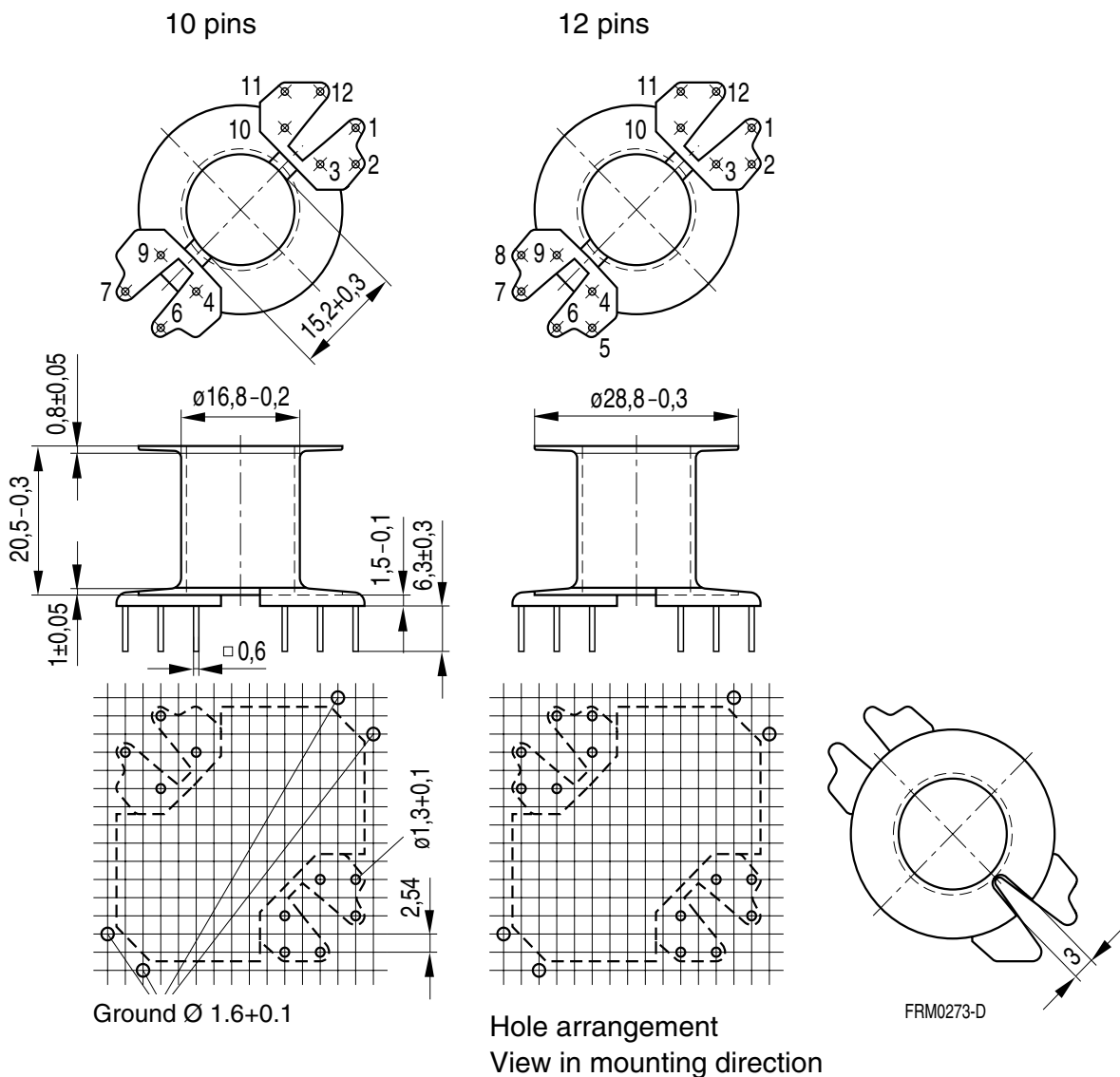

Coil former for power applications

Material: GFR polyterephthalate (UL 94 V-0, insulation class to IEC 60085:
 $F \triangleq$ max. operating temperature 155 °C), color code black
 Valox 420-SE0® [E45329 (M)], GE PLASTICS B V

Solderability: to IEC 60068-2-20, test Ta, method 1 (aging 3): 235 °C, 2 s

Resistance to soldering heat: to IEC 60068-2-20, test Tb, method 1B: 350 °C, 3.5 s

Winding: see Data Book 2007, chapter "Processing notes, 2.1"

For matching clamp and insulating washer see page 5.

Sections	A_N mm ²	l_N mm	A_R value $\mu\Omega$	Pins	Ordering code
1	106	71.5	23	12	B65888C1512T001

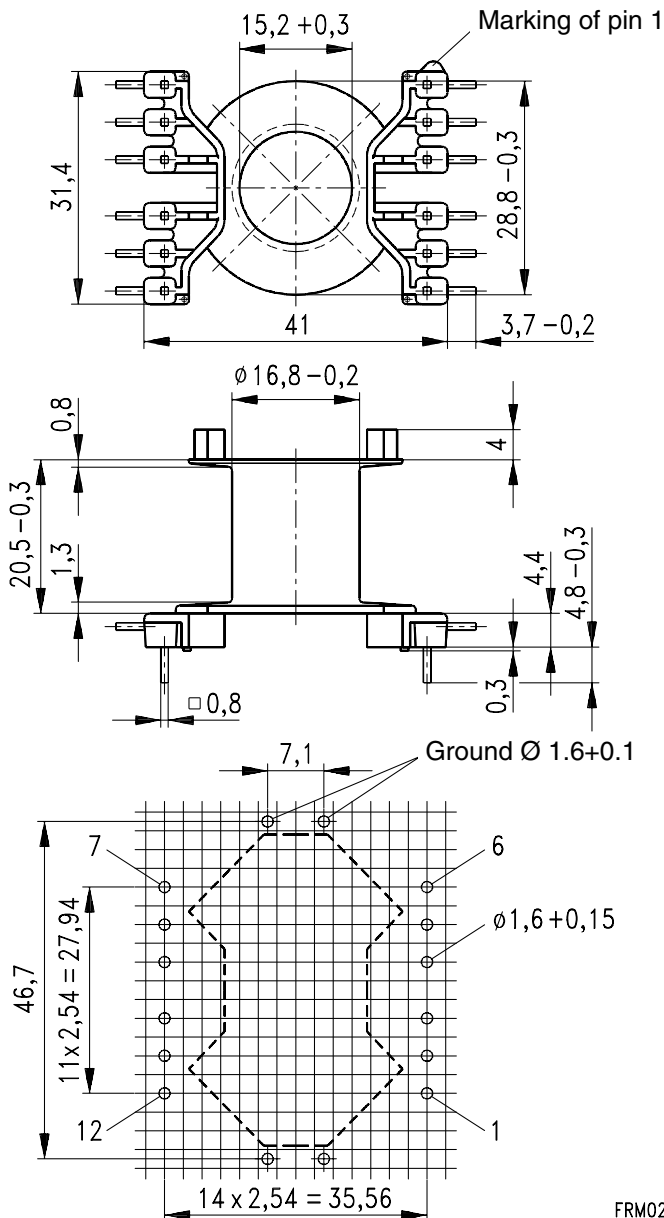

Hole arrangement
 View in mounting direction
 (Note half pitch!)

FRM0228-J

Clamp

- With ground terminal, made of stainless spring steel (tinned), 0.5 mm thick
- Solderability to IEC 60068-2-20, test Ta, method 1 (aging 3): 235 °C, 2 s

Insulating washer for double-clad PCBs

- Made of polycarbonate (UL 94 V-0, insulation class to IEC 60085: E \geq 120 °C), 0.3 mm thick
Makrofol DPF 5026, [E41613 (M)], natural color, BAYER MATERIALSCIENCE AG

	Ordering code
Clamp (ordering code per piece, 2 are required)	B65888A2002X000
Insulating washer (bulk)	B65888B2005X000

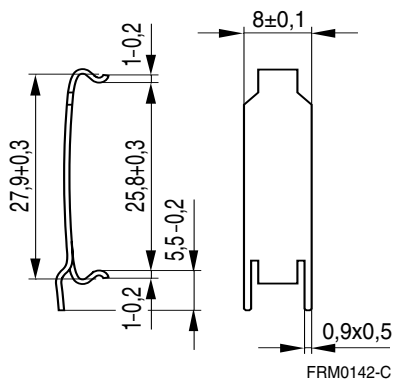
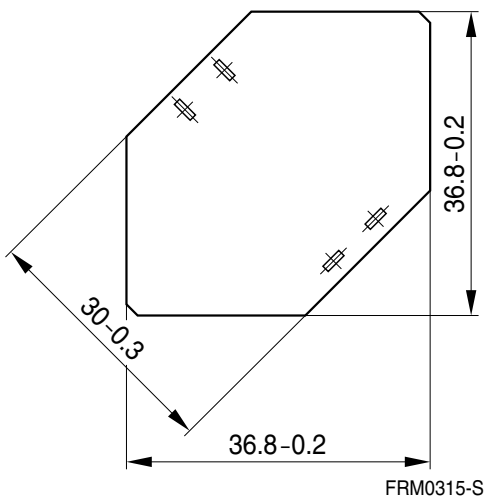
Clamp

Insulating washer

RM 14 »Low Profile«
Core
B65887P

- To IEC 62317-4
- For compact transformers
- Without center hole
- Delivery mode: sets

Magnetic characteristics (per set)

$$\Sigma l/A = 0.25 \text{ mm}^{-1}$$

$$l_e = 50.9 \text{ mm}$$

$$A_e = 201 \text{ mm}^2$$

$$A_{\text{min}} = 170 \text{ mm}^2$$

$$V_e = 10230 \text{ mm}^3$$

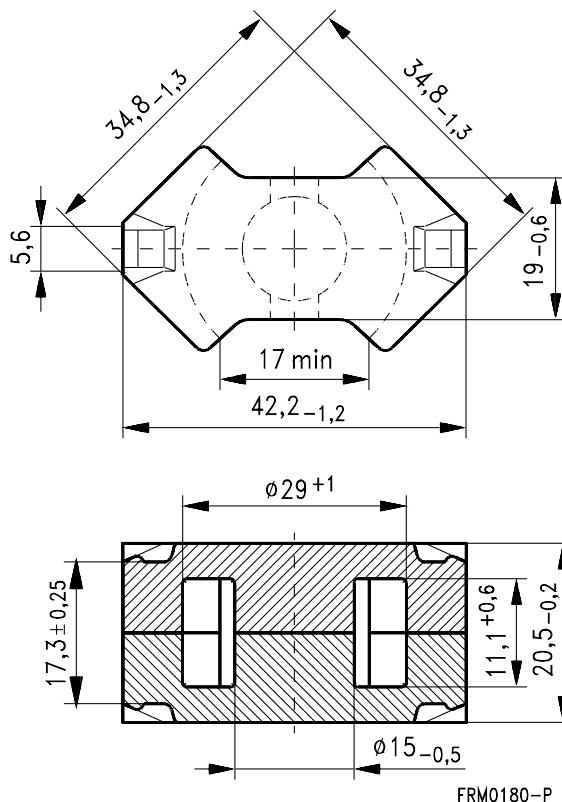
Approx. weight 55 g/set

Ungapped

Material	A_L value nH	μ_e	P_V W/set	Ordering code
N49	5100 +30/-20%	1030	< 2.0 (50 mT, 500 kHz, 100 °C)	B65887P0000R049
N92	5400 +30/-20%	1090	< 6.1 (200 mT, 100 kHz, 100 °C)	B65887P0000R092
N87	7100 +30/-20%	1430	< 5.5 (200 mT, 100 kHz, 100 °C)	B65887P0000R087

Mechanical stress and mounting

Ferrite cores have to meet mechanical requirements during assembling and for a growing number of applications. Since ferrites are ceramic materials one has to be aware of the special behavior under mechanical load.

As valid for any ceramic material, ferrite cores are brittle and sensitive to any shock, fast changing or tensile load. Especially high cooling rates under ultrasonic cleaning and high static or cyclic loads can cause cracks or failure of the ferrite cores.

For detailed information see Data Book 2007, chapter “General – Definitions, 8.1”.

Effects of core combination on A_L value

Stresses in the core affect not only the mechanical but also the magnetic properties. It is apparent that the initial permeability is dependent on the stress state of the core. The higher the stresses are in the core, the lower is the value for the initial permeability. Thus the embedding medium should have the greatest possible elasticity.

For detailed information see Data Book 2007, chapter “General – Definitions, 8.2”.

Heating up

Ferrites can run hot during operation at higher flux densities and higher frequencies.

NiZn-materials

The magnetic properties of NiZn-materials can change irreversible in high magnetic fields.

Processing notes

- The start of the winding process should be soft. Else the flanges may be destroyed.
- To strong winding forces may blast the flanges or squeeze the tube that the cores can no more be mount.
- To long soldering time at high temperature (>300 °C) may effect coplanarity or pin arrangement.
- Not following the processing notes for soldering of the J-leg terminals may cause solderability problems at the transformer because of pollution with Sn oxyd of the tin bath or burned insulation of the wire. For detailed information see Data Book 2007, chapter “Processing notes, 2.2”.
- The dimensions of the hole arrangement have fixed values and should be understood as a recommendation for drilling the printed circuit board. For dimensioning the pins, the group of holes can only be seen under certain conditions, as they fit into the given hole arrangement. To avoid problems when mounting the transformer, the manufacturing tolerances for positioning the customers’ drilling process must be considered by increasing the hole diameter.

Important notes

The following applies to all products named in this publication:

1. Some parts of this publication contain **statements about the suitability of our products for certain areas of application**. These statements are based on our knowledge of typical requirements that are often placed on our products in the areas of application concerned. We nevertheless expressly point out **that such statements cannot be regarded as binding statements about the suitability of our products for a particular customer application**. As a rule, EPCOS is either unfamiliar with individual customer applications or less familiar with them than the customers themselves. For these reasons, it is always ultimately incumbent on the customer to check and decide whether an EPCOS product with the properties described in the product specification is suitable for use in a particular customer application.
2. We also point out that **in individual cases, a malfunction of passive electronic components or failure before the end of their usual service life cannot be completely ruled out in the current state of the art, even if they are operated as specified**. In customer applications requiring a very high level of operational safety and especially in customer applications in which the malfunction or failure of a passive electronic component could endanger human life or health (e.g. in accident prevention or life-saving systems), it must therefore be ensured by means of suitable design of the customer application or other action taken by the customer (e.g. installation of protective circuitry or redundancy) that no injury or damage is sustained by third parties in the event of malfunction or failure of a passive electronic component.
3. **The warnings, cautions and product-specific notes must be observed.**
4. In order to satisfy certain technical requirements, **some of the products described in this publication may contain substances subject to restrictions in certain jurisdictions (e.g. because they are classed as “hazardous”)**. Useful information on this will be found in our Material Data Sheets on the Internet (www.epcos.com/material). Should you have any more detailed questions, please contact our sales offices.
5. We constantly strive to improve our products. Consequently, **the products described in this publication may change from time to time**. The same is true of the corresponding product specifications. Please check therefore to what extent product descriptions and specifications contained in this publication are still applicable before or when you place an order.
We also **reserve the right to discontinue production and delivery of products**. Consequently, we cannot guarantee that all products named in this publication will always be available.
6. Unless otherwise agreed in individual contracts, **all orders are subject to the current version of the “General Terms of Delivery for Products and Services in the Electrical Industry” published by the German Electrical and Electronics Industry Association (ZVEI)**.
7. The trade names EPCOS, EPCOS-JONES, Baoke, Alu-X, CeraDiode, CSSP, MLSC, PhaseCap, PhaseMod, SIFI, SIFERRIT, SIKOREL, SilverCap, SIMID, SIOV, SIP5D, SIP5K, UltraCap, WindCap are **trademarks registered or pending** in Europe and in other countries. Further information will be found on the Internet at www.epcos.com/trademarks.