



Ferrites and accessories

RM 4, RM 4 LP
Cores and accessories

Series/Type: B65803, B65804, B65806, B65539

Date: September 2006/October 2007/January 2010

- To IEC 62317-4
- Core without center hole for transformer applications
- Delivery mode: sets

Magnetic characteristics (per set)

	with center hole	without center hole	
$\Sigma l/A$	1.9	1.7	mm ⁻¹
l_e	21	22	mm
A_e	11	13	mm ²
A_{min}	—	11.3	mm ²
V_e	231	286	mm ³

Approx. weight (per set)

m	1.45	1.65	g

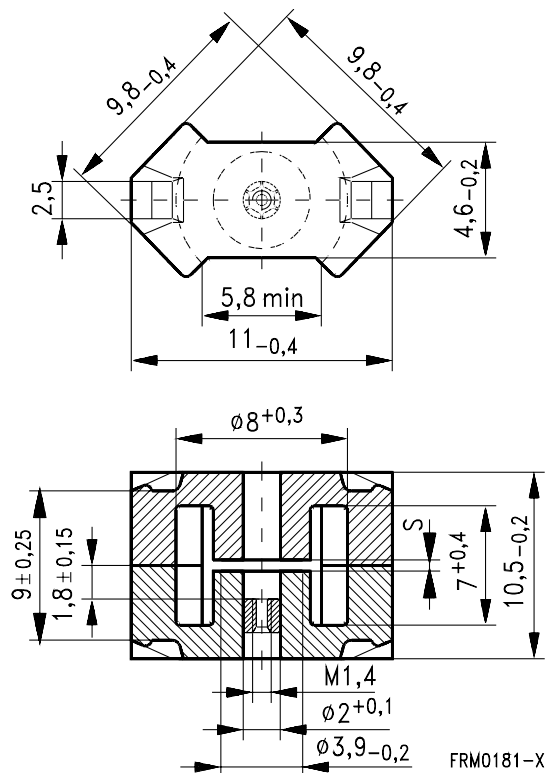
Gapped

Material	A_L value nH	s approx. mm	μ_e	Ordering code ¹⁾ -A with center hole -N with threaded sleeve
K1	16 ± 3%	1.0	24.2	B65803+0016A001
	25 ± 3%	0.40	37.8	B65803+0025A001
M33	40 ± 3%	0.36	60.4	B65803+0040A033
	63 ± 3%	0.18	96	B65803+0063A033
N48	63 ± 3%	0.16	96	B65803+0063A048
	100 ± 3%	0.10	152	B65803+0100A048
	160 ± 3%	0.06	243	B65803+0160A048

1) Replace the + by the code letter "A" or "N" for the required version.

Ungapped

Material	A _L value nH	μ _e	P _V W/set	Ordering code -J without center hole
N45	1700 +30/-20%	2290		B65803J0000R045
N30	1900 +30/-20%	2560		B65803J0000R030
T35	2800 +40/-30%	3770		B65803J0000Y035
T38	3700 +40/-30%	4980		B65803J0000Y038
N49	750 +30/-20%	1010	< 0.04 (50 mT, 500 kHz, 100 °C)	B65803J0000R049
N87	1100 +30/-20%	1480	< 0.20 (200 mT, 100 kHz, 100 °C)	B65803J0000R087
N97	1100 +30/-20%	1480	< 0.15 (200 mT, 100 kHz, 100 °C)	B65803J0000R097

Coil former

Material: GFR thermosetting plastic (UL 94 V-0, insulation class to IEC 60085:
 H \triangleq max. operating temperature 180 °C), color code blue
 Bakelite UP 3420® [E61040 (M)], HEXION SPECIALTY CHEMICALS GMBH

Solderability: to IEC 60068-2-20, test Ta, method 1 (aging 3): 235 °C, 2 s

Resistance to soldering heat: to IEC 60068-2-20, test Tb, method 1B: 350 °C, 3.5 s

Winding: see Data Book 2007, chapter "Processing notes, 2.1"

Pins squared in the start-of-winding area.

For matching clamp and insulating washers see page 5.

Sections	A_N mm ²	l_N mm	A_R value $\mu\Omega$	Pins	Ordering code
1	7.7	20	89	5 6	B65804K1005D001 B65804K1006D001

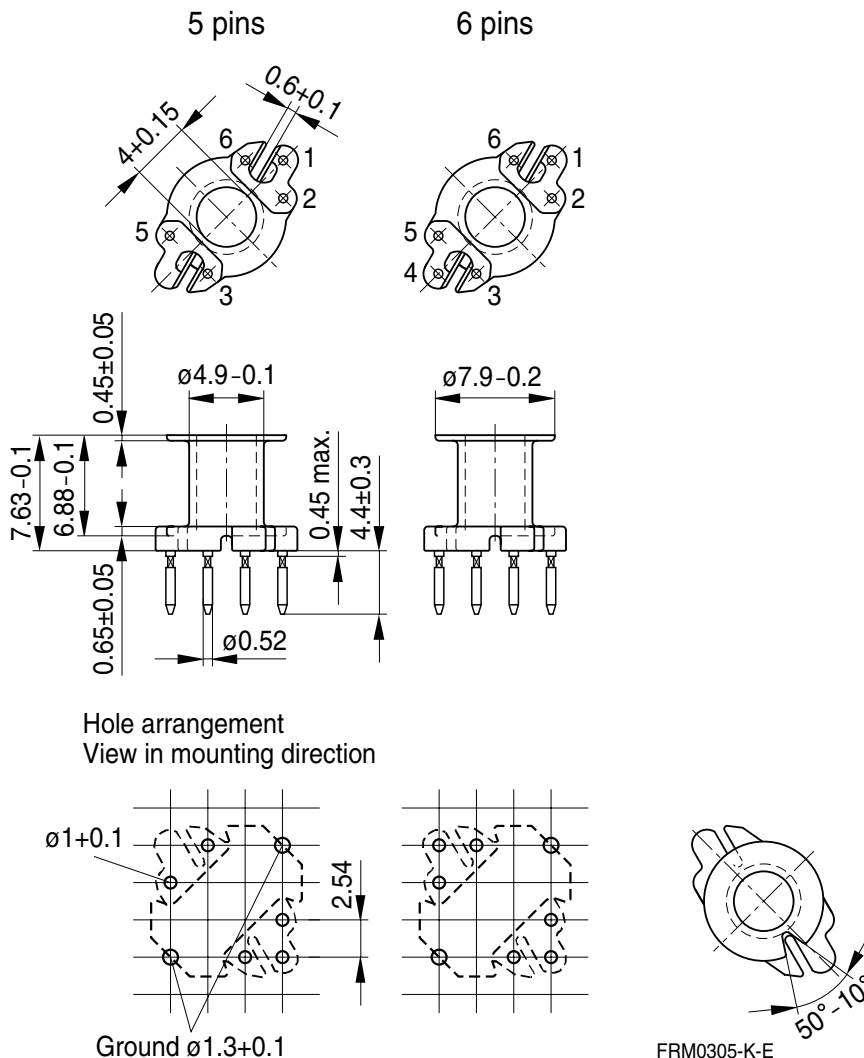

Clamp

- With ground terminal, made of stainless spring steel (tinned), 0.335 mm thick
- Solderability to IEC 60068-2-20, test Ta, method 1 (aging 3): 235 °C, 2 s
- Also available as strip clamp on reels on request

Insulating washer 1 between core and coil former

- For tolerance compensation and for insulation
- Made of polyarylate film (UL 94 V-0, insulation class to IEC 60085: $E \geq 120$ °C), 0.08 mm thick Aryphan F685, [E167358 (M)], natural color, LOFO HIGH TECH FILM GMBH

Insulating washer 2 for double-clad PCBs

- Made of polycarbonate (UL 94 V-0, insulation class to IEC 60085: $E \geq 120$ °C), 0.25 mm thick Makrofol FR, [E118859 (M)], natural color, BAYER MATERIALSCIENCE L L C

	Ordering code
Clamp (ordering code per piece, 2 are required)	B65806A2203X000
Insulating washer 1 (reel packing, PU = 1 reel)	B65804A5000X000
Insulating washer 2 (bulk)	B65804C2005X000

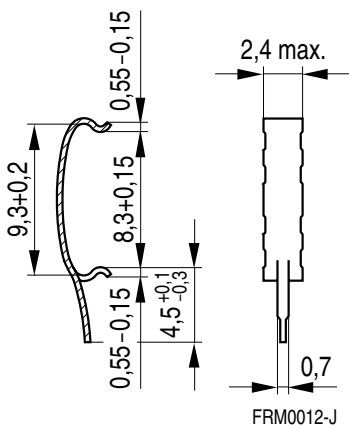
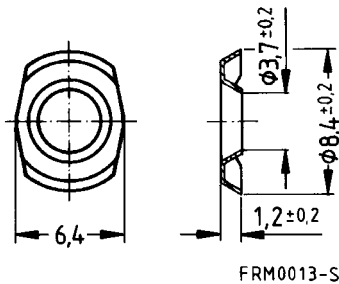
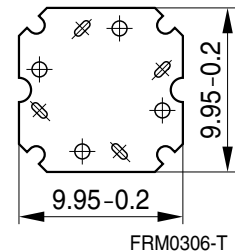
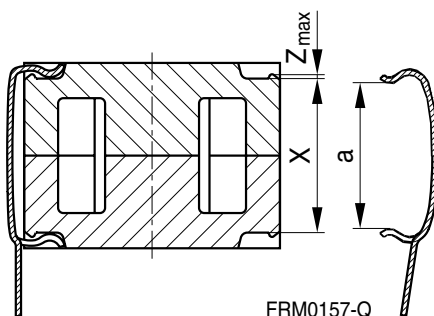
Clamp

Insulating washer 1
(preliminary data)

Insulating washer 2

Clamping forces for RM 4

F_{\min} : Extension of clamp from a to $a_2 = X_{\min}$
 F_{\max} : Extension of clamp from a to $a_1 = X_{\max}$

Clamp opening a (mm)	8.3 +0.15	
Core nose Z_{\max} (mm)	0.15	
Height of core pair X (mm)	X_{\min}	8.75
	X_{\max}	9.25
Clamping force F (N)	F_{\min}	5
	F_{\max}	40

Adjusting screw

- Tube core with thread and core brake made of GFR polyterephthalate
Pocan B3235® [E245249 (M)], LANXESS AG

Figure	Tube core		Color code	Ordering code
	Ø × length (mm)	Material		
a	1.81 × 2.0	K1	yellow	B65539C1003X001
a	1.81 × 2.7	K1	gray	B65539C1002X001
a	1.81 × 2.7	N22	red	B65539C1002X022
b	1.81 × 3.4	N22	green	B65806C3001X022

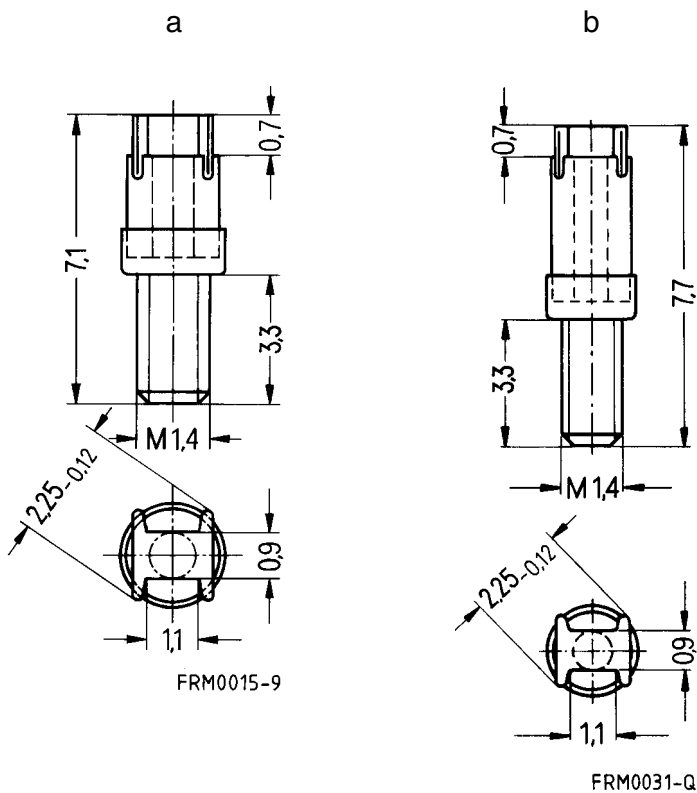

RM 4 »Low Profile«
Core
B65803P

- To IEC 62317-4
- For compact transformers with high inductance
- Without center hole
- Delivery mode: sets

Magnetic characteristics (per set)

$$\Sigma l/A = 1.2 \text{ mm}^{-1}$$

$$l_e = 17.3 \text{ mm}$$

$$A_e = 14.5 \text{ mm}^2$$

$$A_{\text{min}} = 11.3 \text{ mm}^2$$

$$V_e = 251 \text{ mm}^3$$

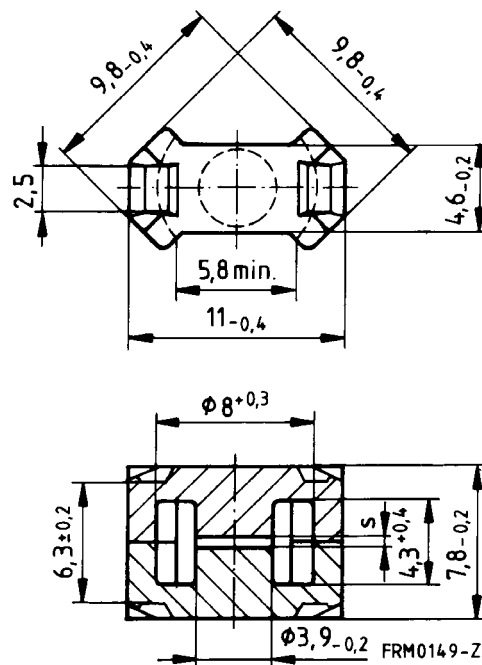
Approx. weight 1.2 g/set

Ungapped

Material	A _L value nH	μ _e	P _V W/set	Ordering code
T38	5000 +40/-30%	4750		B65803P0000Y038
N49	950 +30/-20%	900	< 0.04 (50 mT, 500 kHz, 100 °C)	B65803P0000R049
N92	1000 +30/-20%	950	< 0.14 (200 mT, 100 kHz, 100 °C)	B65803P0000R092
N87	1300 +30/-20%	1230	< 0.12 (200 mT, 100 kHz, 100 °C)	B65803P0000R087

Clamp

- With ground terminal, made of stainless spring steel (tinned), 0.3 mm thick,
Without ground terminal, made of stainless spring steel, 0.3 mm thick
- Solderability to IEC 60068-2-20, test Ta, method 1 (aging 3): 235 °C, 2 s
- Clamping force 40 N per pair of clamps (typical value)
- Also available as strip clamp on reels on request

Insulating washer 1 between core and coil former

- For tolerance compensation and for insulation
- Made of polyarylate film (UL 94 V-0, insulation class to IEC 60085: E \geq 120 °C), 0.08 mm thick
Aryphan F685, [E167358 (M)], natural color, LOFO HIGH TECH FILM GMBH

Insulating washer 2 for double-clad PCBs

- Made of polycarbonate (UL 94 V-0, insulation class to IEC 60085: E \geq 120 °C), 0.25 mm thick
Makrofol FR, [E118859 (M)], natural color, BAYER MATERIALSCIENCE L L C

	Ordering code
Clamp with ground terminal (ordering code per piece, 2 are required)	B65804P2203X000
Clamp without ground terminal (ordering code per piece, 2 are required)	B65804P2204X000
Insulating washer 1 (reel packing, PU = 1 reel)	B65804A5000X000
Insulating washer 2 (bulk)	B65804C2005X000

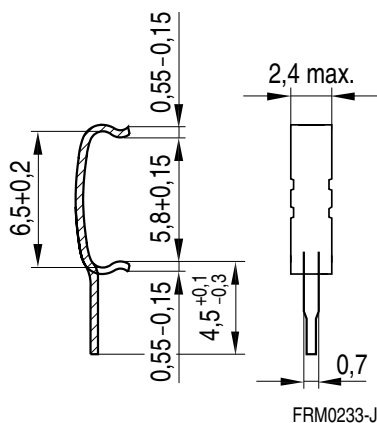
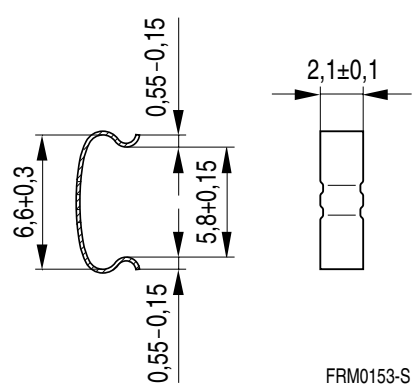
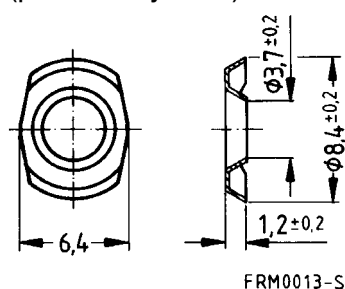
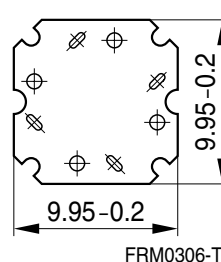
Clamp with ground terminal

Clamp without ground terminal

Insulating washer 1
(preliminary data)

Insulating washer 2



SMD coil former with J terminals

Material: GFR liquid crystal polymer (UL 94 V-0, insulation class to IEC 60085:
 F \triangleq max. operating temperature 155 °C), color code black
 Vectra C 130 [E83005 (M)], TICONA

Solderability: to IEC 60068-2-58, test Td, method 6 (Group 3): 245 °C, 3 s

Resistance to soldering heat: to IEC 60068-2-58, test Td, method 6 (Group 3): 255 °C, 10 s
 permissible soldering temperature for wire-wrap connection on coil former: 400 °C, 1 s

Winding: see Data Book 2007, chapter "Processing notes, 2.1"

Clamp

- Without ground terminal, made of stainless spring steel, 0.3 mm thick
- Also available as strip clamp (each carton containing 2 reels)

Sections	A _N mm ²	l _N mm	A _R value μΩ	Terminals ¹⁾	Ordering code
1	5.0	20.1	138	10	B65804B6010T001
Clamp(ordering code per piece, 2 are required)					B65804P2204X000

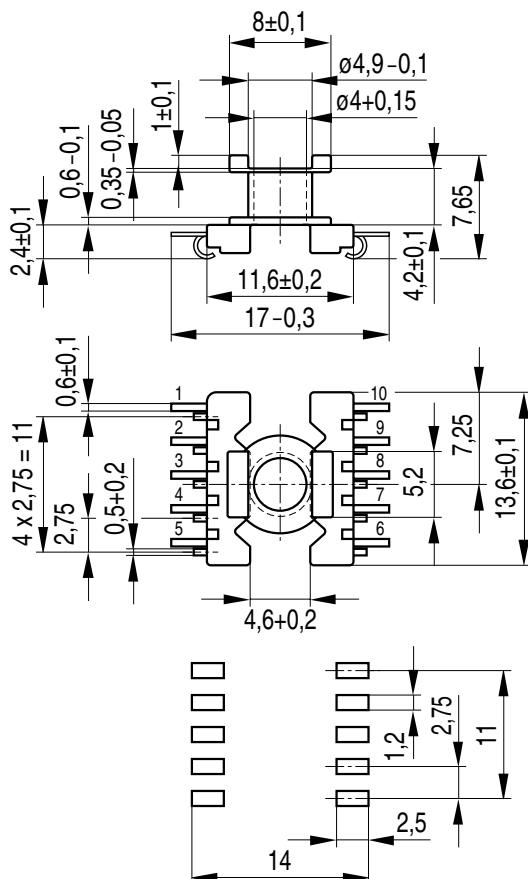
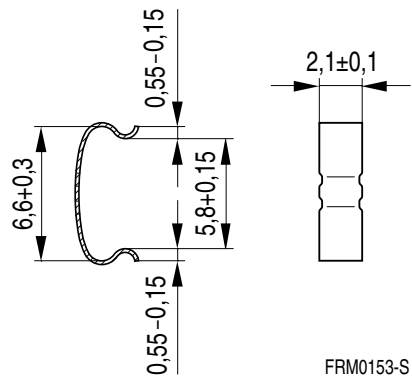
Coil former

Clamp

Recommended
PCB layout

FRM0258-5

1) 6 and 8 terminals on request

Mechanical stress and mounting

Ferrite cores have to meet mechanical requirements during assembling and for a growing number of applications. Since ferrites are ceramic materials one has to be aware of the special behavior under mechanical load.

As valid for any ceramic material, ferrite cores are brittle and sensitive to any shock, fast changing or tensile load. Especially high cooling rates under ultrasonic cleaning and high static or cyclic loads can cause cracks or failure of the ferrite cores.

For detailed information see Data Book 2007, chapter “General – Definitions, 8.1”.

Effects of core combination on A_L value

Stresses in the core affect not only the mechanical but also the magnetic properties. It is apparent that the initial permeability is dependent on the stress state of the core. The higher the stresses are in the core, the lower is the value for the initial permeability. Thus the embedding medium should have the greatest possible elasticity.

For detailed information see Data Book 2007, chapter “General – Definitions, 8.2”.

Heating up

Ferrites can run hot during operation at higher flux densities and higher frequencies.

NiZn-materials

The magnetic properties of NiZn-materials can change irreversible in high magnetic fields.

Processing notes

- The start of the winding process should be soft. Else the flanges may be destroyed.
- To strong winding forces may blast the flanges or squeeze the tube that the cores can no more be mount.
- To long soldering time at high temperature (>300 °C) may effect coplanarity or pin arrangement.
- Not following the processing notes for soldering of the J-leg terminals may cause solderability problems at the transformer because of pollution with Sn oxyd of the tin bath or burned insulation of the wire. For detailed information see Data Book 2007, chapter “Processing notes, 2.2”.
- The dimensions of the hole arrangement have fixed values and should be understood as a recommendation for drilling the printed circuit board. For dimensioning the pins, the group of holes can only be seen under certain conditions, as they fit into the given hole arrangement. To avoid problems when mounting the transformer, the manufacturing tolerances for positioning the customers’ drilling process must be considered by increasing the hole diameter.

Important notes

The following applies to all products named in this publication:

1. Some parts of this publication contain **statements about the suitability of our products for certain areas of application**. These statements are based on our knowledge of typical requirements that are often placed on our products in the areas of application concerned. We nevertheless expressly point out **that such statements cannot be regarded as binding statements about the suitability of our products for a particular customer application**. As a rule, EPCOS is either unfamiliar with individual customer applications or less familiar with them than the customers themselves. For these reasons, it is always ultimately incumbent on the customer to check and decide whether an EPCOS product with the properties described in the product specification is suitable for use in a particular customer application.
2. We also point out that **in individual cases, a malfunction of electronic components or failure before the end of their usual service life cannot be completely ruled out in the current state of the art, even if they are operated as specified**. In customer applications requiring a very high level of operational safety and especially in customer applications in which the malfunction or failure of an electronic component could endanger human life or health (e.g. in accident prevention or life-saving systems), it must therefore be ensured by means of suitable design of the customer application or other action taken by the customer (e.g. installation of protective circuitry or redundancy) that no injury or damage is sustained by third parties in the event of malfunction or failure of an electronic component.
3. **The warnings, cautions and product-specific notes must be observed.**
4. In order to satisfy certain technical requirements, **some of the products described in this publication may contain substances subject to restrictions in certain jurisdictions (e.g. because they are classed as hazardous)**. Useful information on this will be found in our Material Data Sheets on the Internet (www.epcos.com/material). Should you have any more detailed questions, please contact our sales offices.
5. We constantly strive to improve our products. Consequently, **the products described in this publication may change from time to time**. The same is true of the corresponding product specifications. Please check therefore to what extent product descriptions and specifications contained in this publication are still applicable before or when you place an order.

We also **reserve the right to discontinue production and delivery of products**. Consequently, we cannot guarantee that all products named in this publication will always be available. The aforementioned does not apply in the case of individual agreements deviating from the foregoing for customer-specific products.

6. Unless otherwise agreed in individual contracts, **all orders are subject to the current version of the “General Terms of Delivery for Products and Services in the Electrical Industry” published by the German Electrical and Electronics Industry Association (ZVEI)**.
7. The trade names EPCOS, BAOKE, Alu-X, CeraDiode, CSMP, CSSP, CTVS, DeltaCap, DigiSiMic, DSSP, MiniBlue, MiniCell, MKK, MLSC, MotorCap, PCC, PhaseCap, PhaseCube, PhaseMod, PhiCap, SIFERRIT, SIFI, SIKOREL, SilverCap, SIMDAD, SiMic, SIMID, SineFormer, SIOV, SIP5D, SIP5K, ThermoFuse, WindCap are **trademarks registered or pending** in Europe and in other countries. Further information will be found on the Internet at www.epcos.com/trademarks.