



## **Ferrites and accessories**

P 30 x 19, core and accessories

**Series/Type:** B65701, B65702, B65705, B65679

**Date:** September 2011

**Core**

- Standard: to IEC 60133
- Delivery mode: sets

**Magnetic characteristics**

	with center hole	without center hole	
$\Sigma I/A$	0.33	0.32	mm <sup>-1</sup>
$I_e$	45	46	mm
$A_e$	136	145	mm <sup>2</sup>
$A_{min}$	—	117	mm <sup>2</sup>
$V_e$	6120	6670	mm <sup>3</sup>

**Approx. weight (per set)**

	with center hole	without center hole	
m	36	38	g

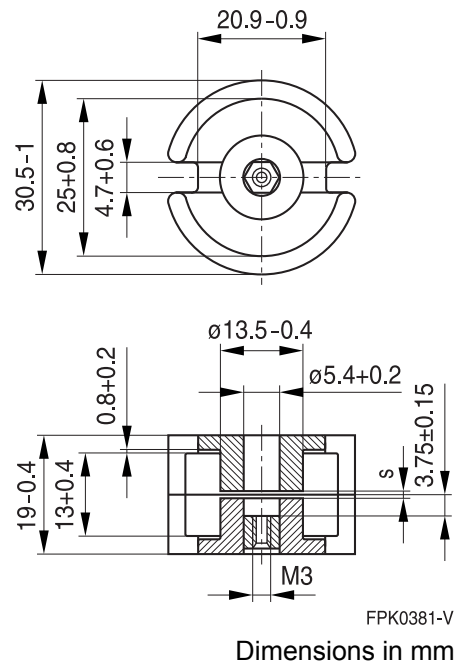
**Gapped**

Material	AL value nH	s approx mm	$\mu_e$	Ordering code <sup>1</sup> - D with center hole - T with threaded sleeve
N48	250 ±3%	0.72	66	B65701+0250A048
	400 ±3%	0.40	105	B65701+0400A048
	630 ±3%	0.22	166	B65701+0630A048
	1000 ±3%	0.12	263	B65701+1000A048
	2000 ±5%	0.05	527	B65701D2000J048

**Ungapped**

Material	AL value nH	$\mu_e$	$P_V$ W/set	Ordering code - D with center hole - T with threaded sleeve
N48	6200 +30/-20%	1630		B65701D0000R048
N30	11500 +30/-30%	2900		B65701W0000R030
T38	28000 +40/-30%	7070		B65701W0000Y038
N87	6400 +30/-20%	1620	< 1.9 (200 mT, 100 kHz, +100 °C)	B65701W0000R087

<sup>1</sup> Replace + by D or T for required version

**Coil former**

Standard: to IEC 60133

Material: GFR polyterephthalate (UL 94 V-0, insulation class to IEC 60085:

$F \hat{=}$  max. operating temperature +155 °C), color code black,

Valox 420-SE0® [E45329 (M)], SABIC INNOVATIVE PLASTICS

Winding: see Data Book 2007, chapter "Processing notes"

Coil former				Ordering code
Sections	$A_N$ mm <sup>2</sup>	$l_N$ mm	$A_R$ value $\mu\Omega$	
1	48	60	46	B65702B0000T001

Coil former:

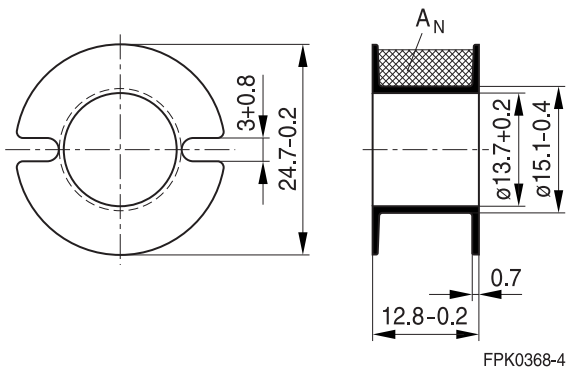

**Mounting assembly for printed circuit boards**

- The set comprises a terminal carrier and a yoke
- For snap-in connection

**Terminal carrier**

Material: GFR polyterephthalate (UL 94 V-0, insulation class to IEC 60085:  
 $F \cong$  max. operating temperature +155 °C), color code gray,  
 Pocan B4235® [E245249 (M)], LANXESS AG

Solderability: to IEC 60068-2-20, test Ta, method 1 (aging 3): +235 °C, 2 s;

Resistance to soldering heat: to IEC 60068-2-20, test Tb, method 1B: +350 °C, 3.5 s

**Yoke**

Spring yoke, made of tinned nickel silver (0.5 mm), with ground terminal

Complete mounting assembly (8 solder terminals)

Ordering code: B65705B0003X000

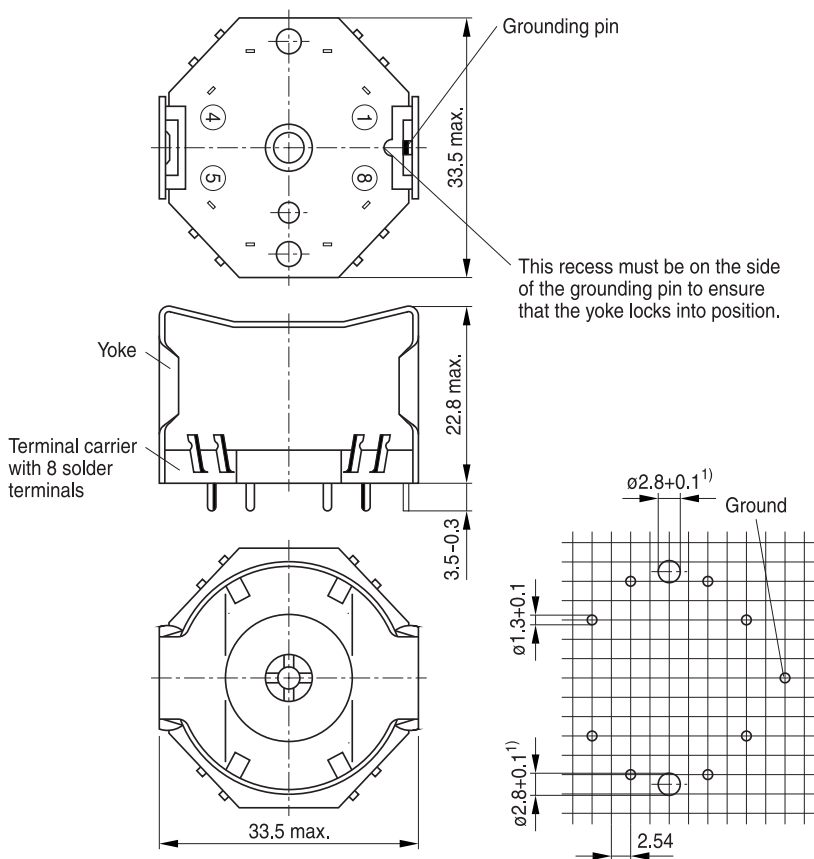

1) The 2.8 mm hole is only necessary for additional fixing with M2.5 screw.

FPK0382-4-E

**Adjusting screw**

- Tube core with thread and core brake made of GFR polyterephthalate, Pocan B3235® [E245249 (M)], LANXESS AG

Tube core			Ordering code
Ø x length (mm)	Material	Color code	
4.55 x 6.3	N22	red	B65679E0003X022
4.98 x 6.3	N22	black	B65679E0002X022

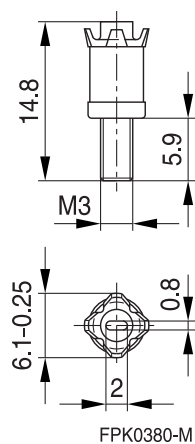
**Note:**

Due to the limited distance between adjusting screw and internal borehole, the entire assembly must be accurately centered

### **Mechanical stress and mounting**

Ferrite cores have to meet mechanical requirements during assembly and for a growing number of applications. Since ferrites are ceramic materials one has to be aware of their special behavior under mechanical load.

Just like any ceramic material, ferrite cores are brittle and sensitive to any shock, fast changing or tensile load. Especially fast cooling rates under ultrasonic cleaning, high static and cyclic loads can cause cracks or failure of the ferrite cores.

For detailed information see Data Book 2007, chapter “General – Definitions, 8.1”.

### **Effects of core combination on AL value**

Stresses in the core affect not only the mechanical but also the magnetic properties. It is apparent that the initial permeability is dependent on the stress state of the core. The higher the stresses are in the core, the lower the value for the initial permeability. Thus, the embedding medium should offer the greatest possible elasticity.

For detailed information see Data Book 2007, chapter “General – Definitions, 8.2”.

### **Heating up**

Ferrites can run hot during operation at higher flux densities and higher frequencies.

### **NiZn-materials**

The magnetic properties of NiZn-materials can change irreversibly when exposed to strong magnetic fields.

### **Processing notes**

The start of the winding process should be soft. Otherwise, the flanges may be destroyed.

Excessive winding forces may damage the flanges or squeeze the tube so that the cores can no longer be mounted.

Excessive soldering time at high temperature (>300 °C) may affect coplanarity or pin arrangement.

Not following the processing notes for soldering of the J-leg terminals may cause solderability problems at the transformer because of contamination with tin oxide (SnO) from the tin bath or burned insulation from the wire. For detailed information see Data Book 2007, chapter “Processing notes, 2.2”.

The dimensions of the pin hole arrangement are fixed and should be understood as an ideal recommendation for drilling the printed circuit board. In order to avoid problems when mounting the transformer, customers should make allowances for manufacturing tolerances in the drilling and pick-and-place processes by increasing the diameter of the pin holes

## Important notes

The following applies to all products named in this publication:

1. Some parts of this publication contain **statements about the suitability of our products for certain areas of application**. These statements are based on our knowledge of typical requirements that are often placed on our products in the areas of application concerned. We nevertheless expressly point out **that such statements cannot be regarded as binding statements about the suitability of our products for a particular customer application**. As a rule, EPCOS is either unfamiliar with individual customer applications or less familiar with them than the customers themselves. For these reasons, it is always ultimately incumbent on the customer to check and decide whether an EPCOS product with the properties described in the product specification is suitable for use in a particular customer application.
2. We also point out that **in individual cases, a malfunction of electronic components or failure before the end of their usual service life cannot be completely ruled out in the current state of the art, even if they are operated as specified**. In customer applications requiring a very high level of operational safety and especially in customer applications in which the malfunction or failure of an electronic component could endanger human life or health (e.g. in accident prevention or life-saving systems), it must therefore be ensured by means of suitable design of the customer application or other action taken by the customer (e.g. installation of protective circuitry or redundancy) that no injury or damage is sustained by third parties in the event of malfunction or failure of an electronic component.
3. **The warnings, cautions and product-specific notes must be observed.**
4. In order to satisfy certain technical requirements, **some of the products described in this publication may contain substances subject to restrictions in certain jurisdictions (e.g. because they are classed as hazardous)**. Useful information on this will be found in our Material Data Sheets on the Internet ([www.epcos.com/material](http://www.epcos.com/material)). Should you have any more detailed questions, please contact our sales offices.
5. We constantly strive to improve our products. Consequently, **the products described in this publication may change from time to time**. The same is true of the corresponding product specifications. Please check therefore to what extent product descriptions and specifications contained in this publication are still applicable before or when you place an order. We also **reserve the right to discontinue production and delivery of products**. Consequently, we cannot guarantee that all products named in this publication will always be available. The aforementioned does not apply in the case of individual agreements deviating from the foregoing for customer-specific products.
6. Unless otherwise agreed in individual contracts, **all orders are subject to the current version of the "General Terms of Delivery for Products and Services in the Electrical Industry" published by the German Electrical and Electronics Industry Association (ZVEI)**.
7. The trade names EPCOS, BAOKE, Alu-X, CeraDiode, CSMP, CSSP, CTVS, DeltaCap, DigiSiMic, DSSP, FormFit, MiniBlue, MiniCell, MKD, MKK, MLSC, MotorCap, PCC, PhaseCap, PhaseCube, PhaseMod, PhiCap, SIFERRIT, SIFI, SIKOREL, SilverCap, SIMDAD, SiMic, SIMID, SineFormer, SIOV, SIP5D, SIP5K, ThermoFuse, WindCap are **trademarks registered or pending** in Europe and in other countries. Further information will be found on the Internet at [www.epcos.com/trademarks](http://www.epcos.com/trademarks).