

# 納入仕様書

## SPECIFICATION

仕様書番号

SPEC No. KTS-A12-5957(00)

発行日

DATE 2014-08-19

MESSRS.

LEPCOS ST.PETERSB

御中

貴社品名 CUSTOMER'S PRODUCT NAME

弊社品名 TDK PRODUCT NAME

HF56 T 31X8X19

受領印欄 THIS SPECIFICATION IS RECEIVED

受領日

DATE : YEAR MONTH DAY



TDK KOREA CORPORATION

104, Hyeongoksandan-ro, Cheongbuk-myeon,

Pyeongtaek-si, Gyeonggi-do

451-831 Republic of Korea

TEL:031)8053-1968 FAX:031)8053-1964

営業 TEL:02)3019-4300 FAX:02)3019-4341~4342

技術部門

擔當者	確認者	責任者

## 基本目次 Basic contents

※本仕様書は日本語を優先言語とします。

Japanese language have priority over English in this sheet

## 1. 適用範囲 Scope of Application

当仕様書は、LEPCOS ST.PETERSB 殿へ  
納入するフェライトコアに適用する。

This specification shall be applied to the product ferrite core to be delivered to  
LEPCOS ST.PETERSB

## 2. 製品の名称 Name of Product

当仕様書に定める製品の名称は、HF56 T 31X8X19 とする。

The name of the product to be defined in this specification shall be defined as  
HF56 T 31X8X19

## 3. 記載項目 Description

- 1) 形状寸法 Shape and Dimensions
- 2) 電気的特性 Electrical Characteristics
- 3) 外観 Appearance

## 変更履歴 Revision Records

版 Rev.	年月日 Date	担当 Revised By	変更内容 Revision	
部門名 Div.			制定日 Date	仕様書番号 Spec. No.
TDK KOREA CORPORATION FERRITE DEPARTMENT TECHNICAL SECTION			2014-08-19	KTS-A12-5957(00)

## 1. 形状寸法(単位: mm)

Shape and Dimensions(Unit : mm)

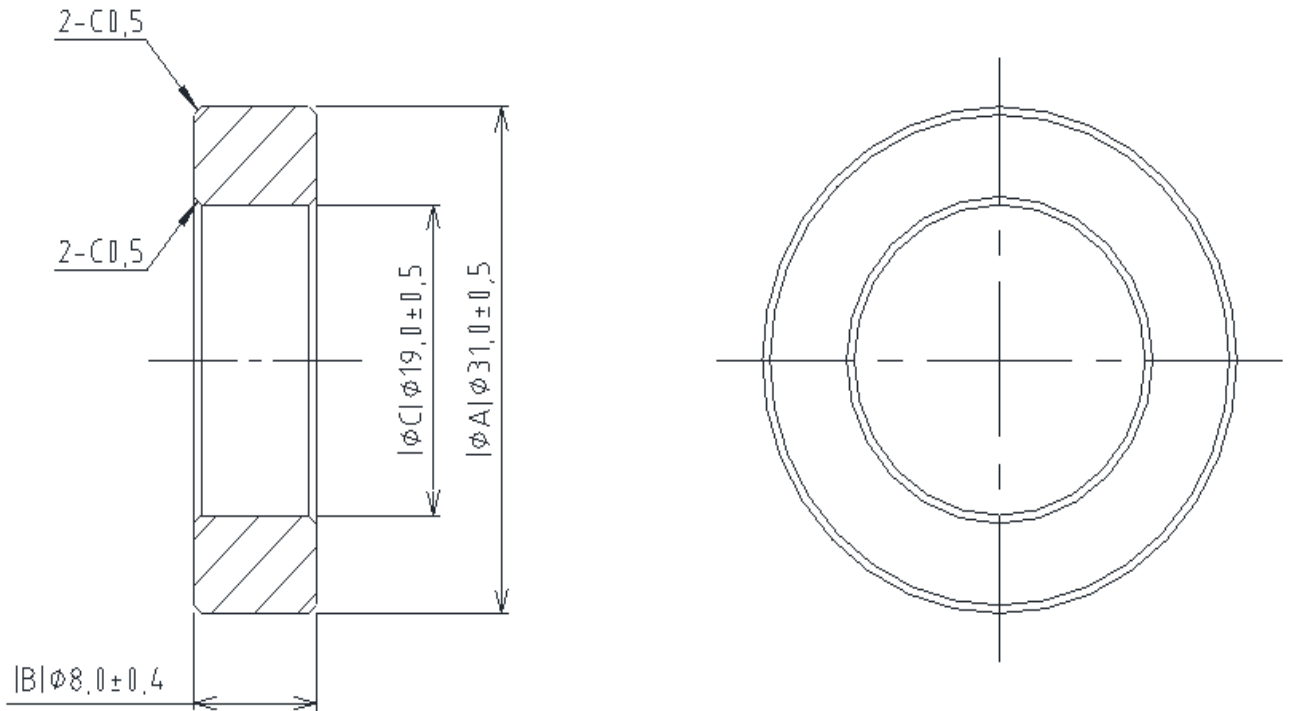

## 2. 電気的特性 Electrical Characteristics

規格 Specification		試験方法 Test method	
Z1[Ω]	14 Min	Wire	Ø1.0, 2UEW, 1Ts. L=60mm
		Test Frequency	F1=10MHz, F2=100MHz
Z2[Ω]	35 Min	Test meter	HP-4991A
		Test meter	

巻線法  
Coil  
method

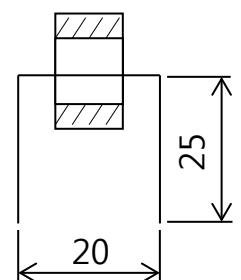

### 3.外観 Appearance

1)バリ、割れ、ヒビはなきこと。 Burr, breakage and cracks not to exist.

#### 2)欠け限度 Chip limit

弊社のその他コア一般賭け限度見本を適用する。

General chip limit samples of our company for others cores to apply.

##### ①欠け限度 Chip limit

上・下面方向 : 表面積の3%以内

On the top or bottom and side surface : 3% less of the area

側面方向 : コアの全長寸法20%(1/5)以内

On the side surface : 20%(1/5) or less of the total core length

##### ②欠け個数 Number of chips

同一表面上に1箇所以内

One or less on one and the same surface

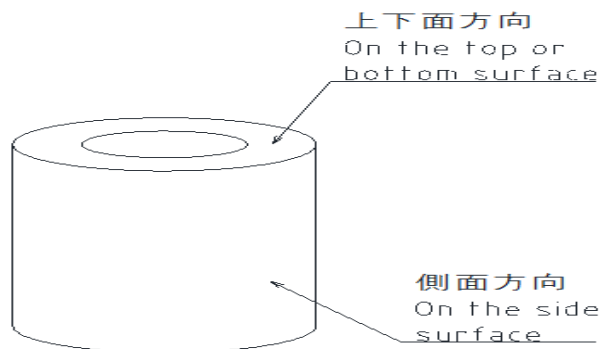

# INSPECTION REPORT(製品検査成績書)

CUSTOMER(納入先)		LEPCOS ST.PETERSB	Lot No.	
TDK Item(TDK品名)		HF56 T 31X8X19	Inspection No.(検査No.)	
CUSTOMER P#		Lot Size [pcs]	Date(発行日)	
			2014年8月19日	
ELECTRONIC PROPERTIES(電気的特性)		QTY[pcs](出荷数量)		

SPEC. (規格)	TEST FREQUENCY	F1=10[MHz], F2=100[MHz]	No.	Z1[Ω]	Z2[Ω]			
		Z1[Ω]	14 Min	1	20.6	50.6		
	Z2[Ω]	35 Min	2	20.6	50.5			
			3	20.6	50.9			
			4	20.6	50.8			
			5	20.7	50.3			
			6	20.6	50.4			
			7	20.7	50.6			
TESTING CONDITIONS	Coil Spec	∅1.0, 2UEW (L=60mm)	8	20.6	50.6			
	Winding	1Ts.	9	20.5	50.8			
	TEST Equipment	HP-4991A	10	20.4	50.1			
			X	20.59	50.56			
			R	0.3	0.8			

DIMENSIONS (UNIT:mm)			Temp (温度)[℃]	25	Humidity (湿度)[%]	45	Shape(外觀)	<b>OK</b>	NG
----------------------	--	--	--------------	----	------------------	----	-----------	-----------	----

項目	∅A	B	∅C										
Spec(規格)	31.0 ±0.5	8.0 ±0.4	19.0 ±0.5										
No.													
1	30.83	8.07	18.94										
2	30.81	8.09	18.98										
3	30.83	8.09	18.98										
4	30.85	8.02	18.98										
5	30.83	8.05	18.96										
6													
7													
8													
9													
10													
X	10.024	2.988	6.046										
R	0.01	0.03	0.01										

Shape(形状略圖)

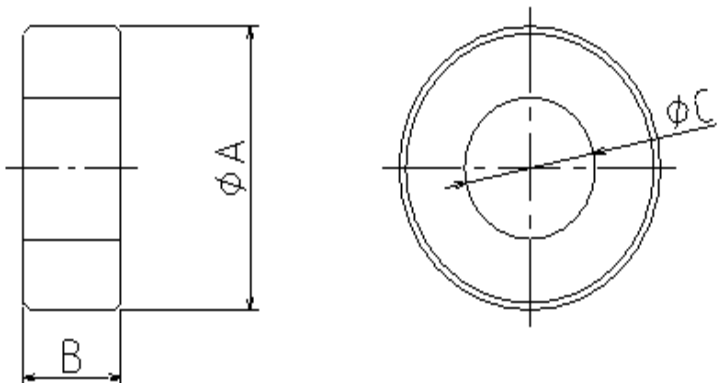

<b>OK</b> 合格	NG 不合格
-----------------	-----------

Approved 確認	Tested 検査
----------------	--------------