

LaserTrim[®] Ceramic Chip Capacitor

RF & Microwave Capacitors, SMT, RoHS

DESCRIPTION

Laser adjustable monolithic ceramic
 Rated voltage - 50V
 Porcelain Capacitors
 Excellent post-trim Q and ESR
 No capacitance drift

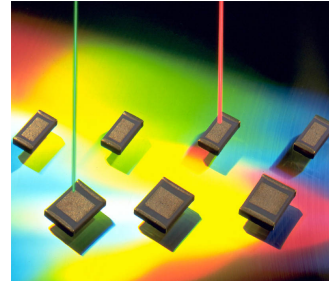

APPLICATIONS

Pagers, RF Modems
 Cellular Communications
 Remote Controls

CIRCUIT APPLICATIONS

Oscillators
 Filters
 Antennas

I. ELECTRICAL SPECIFICATIONS

<i>Parameter</i>	<i>Value</i>
Initial Capacitance Value	1 to 21 pF
Tolerance on the Initial Capacitance Value	-0% / +25%
Working Voltage (WVDC)	50V
Temperature Coefficient	0 +/-30ppm/°C, -55°C to +125°C
Dielectric Withstanding	2.5 x WVDC (50 mA maximum)
Aging	none
Piezo Effects	none

II. MECHANICAL SPECIFICATIONS

<i>Parameter</i>	<i>Value</i>	<i>Comment</i>
Termination Materials All terminations are lead-free	G	gold over nickel barrier
Case Sizes	L14	0603
	L15	0805
	L18	1206
	L41	1210

LaserTrim[®] Ceramic Chip Capacitor

RF & Microwave Capacitors, SMT, RoHS

III. INITIAL CAPACITANCE VALUE

The following chart gives the available initial capacitance values per size and dielectric. The initial capacitance is the value mentioned in the part number; this is therefore the capacitance value exhibited by the LaserTrim[®] prior to any trimming.

Initial Capacitance Value	L14	L15	L18	L41
S	1.0 / 1.5pF		1.0 / 3.0pF	
N	3.0 / 10.0pF	7.0 / 20.0pF		12.0 / 21.0pF

For instance, if size L14 and dielectric S are selected, we can produce a LaserTrim[®] with an initial capacitance value selected from the 1.0 to 1.5pF range.

NB: a prototyping phase might be conducted to fine-tune the internal design if the requested component has not been produced before.

IV. TUNING RANGE

The tuning range is the range of capacitance values that can be reached with trimming. It varies from the initial capacitance value down to the minimum capacitance value. Any capacitance value between 'initial capacitance value' and 'minimum capacitance value' can be reached with trimming.

Initial Capacitance	1pF	2pF	5pF	10pF	20pF
Tuning range	1pF to 0.2pF	2pF to 0.5pF	5pF to 1pF	10pF to 2pF	20pF to 3pF

V. ENVIRONMENTAL SPECIFICATIONS

Parameter	Value
Life Test	1'000 hours, +125°C at 1.5 x WVDC
Moisture Resistance Test	56 days, 93% relative humidity at +40°C 0V, 5V, WVDC

If the terminations are heated up above a particular temperature and/or for too long a period of time, there is a risk of leaching (dissolution of the termination revealing the inner electrodes). The chart below gives the resistance to soldering heat, based on a SAC387 solder bath at 260°C.

Dielectric Type	G
Lasertrim [®]	5 ±1s

LaserTrim[®] Ceramic Chip Capacitor

RF & Microwave Capacitors, SMT, RoHS

VI. OUTLINE DIMENSIONS

Parameter	L14 (0603)	L15 (0805)	L18 (1206)	L41 (1210)
Length (L)	1.60 ±0.30 mm	2.03 ±0.20 mm	3.09 ±0.20 mm	3.30 ±0.20 mm
Width (W)	0.80 ±0.20 mm	1.27 ±0.20 mm	1.52 ±0.20 mm	2.54 ±0.20 mm
Thickness (T)	0.76 mm (max.)	0.76 mm (max.)	0.76 mm (max.)	0.76 mm (max.)
Pad gap	0.10 mm (min)	0.10 mm (min)	0.10 mm (min)	0.10 mm (min)

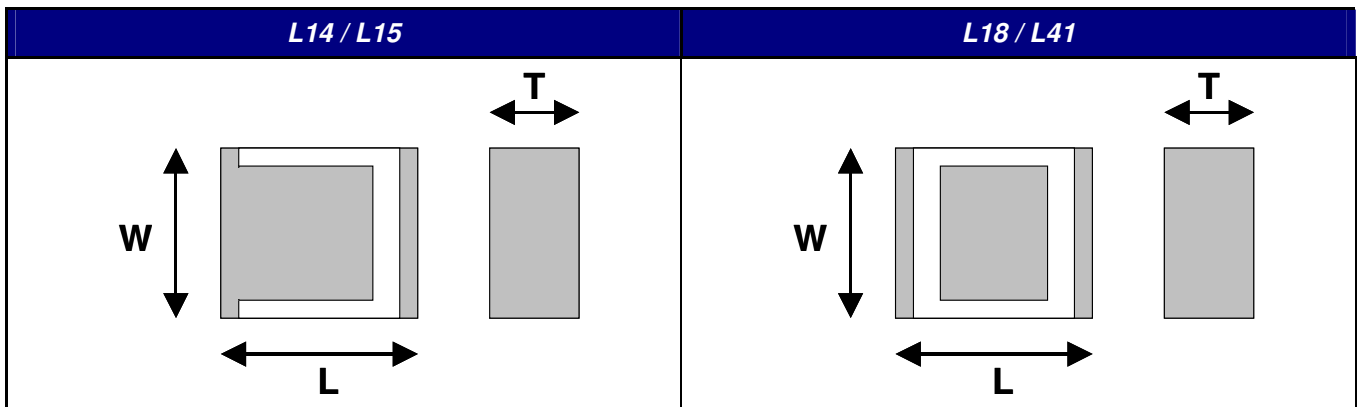

VII. ELECTRODE PATTERN

A "standard electrodes" design is used for the L14/L15 sizes. To keep the same beam trace from one part to another despite this non symmetrical design, laser-trims are always taped in the same position.

A "floating electrodes" design is used for the L18/L41 sizes. This solution provides both a symmetrical design and a better current flow.

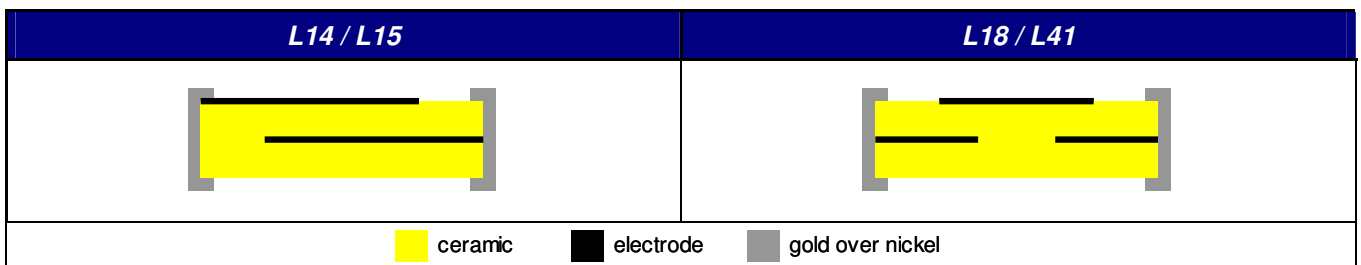

LaserTrim[®] Ceramic Chip Capacitor

RF & Microwave Capacitors, SMT, RoHS

VIII. PART NUMBERING

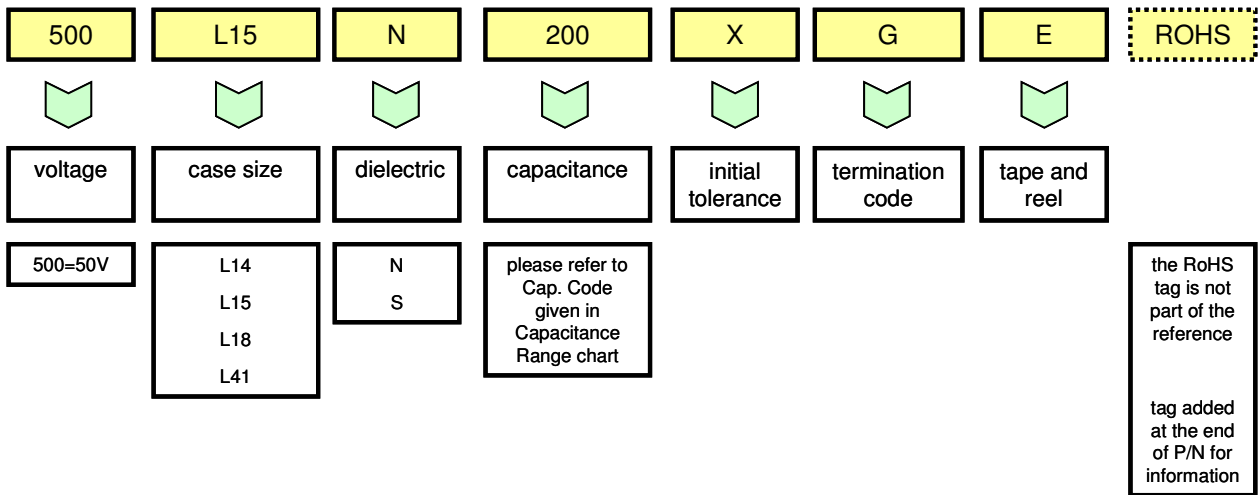

NB: the ROHS tag is for information only and does not belong to the part number itself. This tag is added on our stickers so that our customers can ensure that they use RoHS compliant parts on their process line.

IX. TAPE AND REEL

The following chart gives the number of components per reel.

Size	L14	L15	L18	L41
Quantity per Reel	4'000	4'000	4'500	4'500

LaserTrim[®] Ceramic Chip Capacitor

RF & Microwave Capacitors, SMT, RoHS

X. TYPICAL CHARACTERISTICS

X.1. Typical Quality Factor

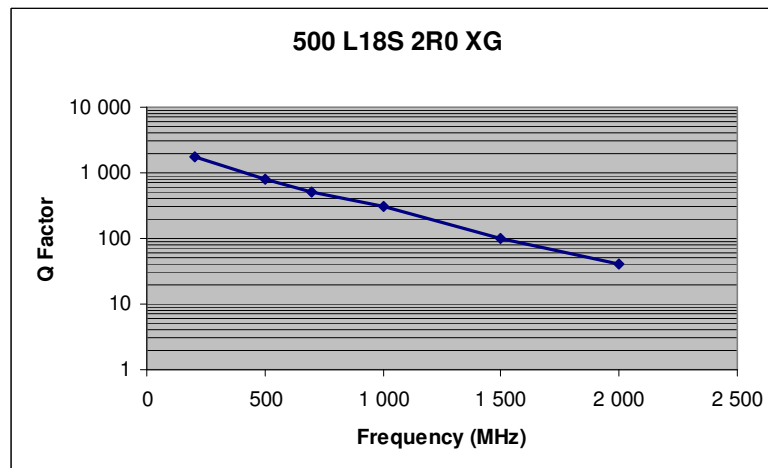
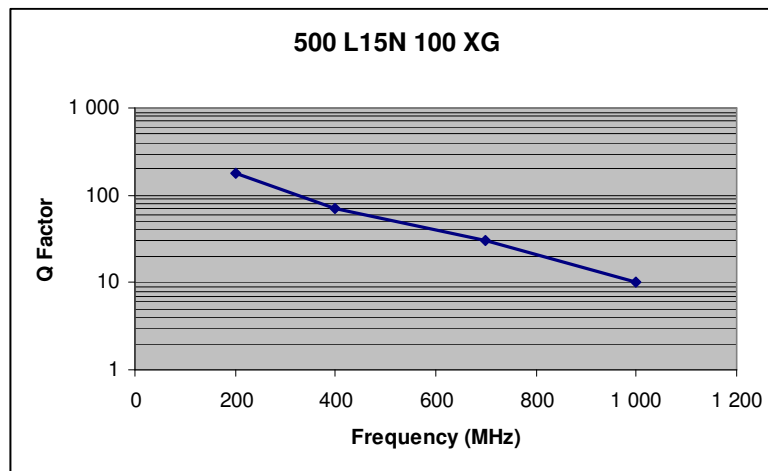

LaserTrim[®] Ceramic Chip Capacitor

RF & Microwave Capacitors, SMT, RoHS

X.2. Typical Equivalent Series Resistance

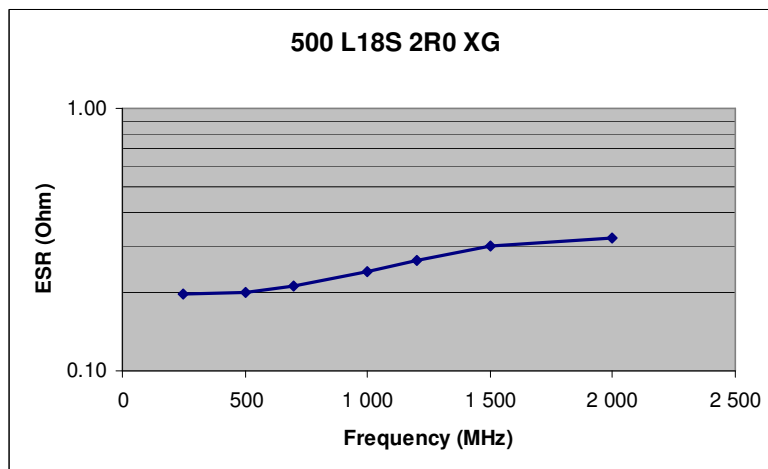
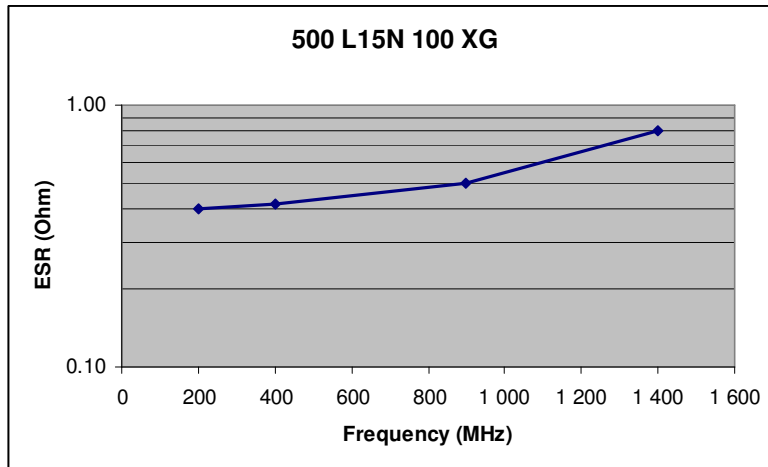

LaserTrim[®] Ceramic Chip Capacitor

RF & Microwave Capacitors, SMT, RoHS

XI. MAJOR ADVANTAGES

- ⇒ Easy functional tuning process automation
- ⇒ High resolution, high accuracy tuning capability
- ⇒ High stability and reliability after adjustment
- ⇒ No trim tool to affect the performance of RF circuits
- ⇒ Suitable for operating in vibrating environments

XII. TECHNOLOGY ANALYSIS

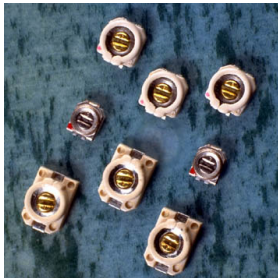
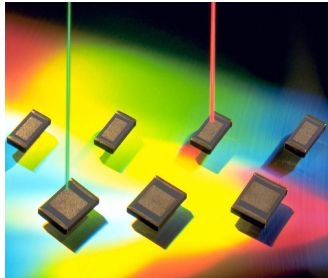
Surface Mount Trimmer Capacitors	LaserTrim [®]
	
+ multiple "pole" settings	+ very low automatic tuning time
+ high voltage rating	+ reduced component placement
+ possibility of undoing trimming	+ no capacitance drift (over time or with vibrations)
- potential drift in capacitance (mechanical, less than 1%)	- no possibility to undo trimming
- temperature coefficient ± 300 ppm/°C	- single "pole" settings

LaserTrim[®] devices are especially well suited for mass-production applications as well as for applications sensitive to vibrations where mechanical un-trimming is prohibited, such as missiles for instance. In order to perform the trimming operation, a laser equipment is needed.

Today, such a laser equipment – low power one would be enough - is very common and widely used (resistor trimming, marking...). Therefore, the LaserTrim[®] capacitors entail a very low unit cost (lower than trimmer capacitors) even for small or medium quantities.

LaserTrim[®] Ceramic Chip Capacitor

RF & Microwave Capacitors, SMT, RoHS

XIII. APPLICATION NOTES

Trimming, which is done by removing part of the surface electrode by laser, has to be carefully carried out to avoid problems. To avoid destroying the electrical path through the surface electrode, and to maintain balance throughout the operation, the laser must be operated along the axial line of the LaserTrim[®].

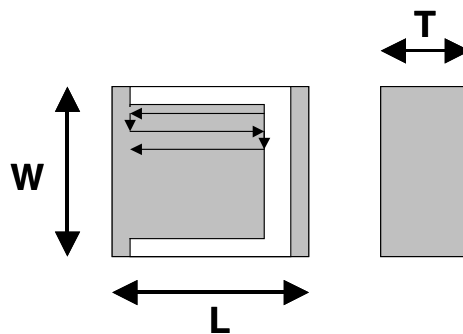

Also, a safe margin between the termination and the laser-trimmed surface must be maintained. Therefore, the L3 distance - inactive length - must remain untrimmed and with a minimum length of 0.10mm.

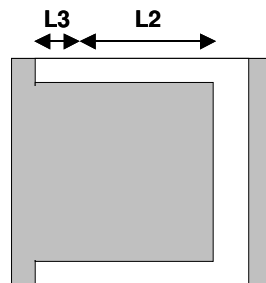

The maximum thickness D_1 of the top electrode is $11\mu\text{m}$. The trimmed depth is measured with reference to the surface of the external top electrode. We consider that an optimum depth for D_2 is $23\mu\text{m}$. Therefore, the recommended trim depth would be $12\mu\text{m}$. The first inner electrode is located at D_3 which equals $40\mu\text{m}$. Therefore the distance between D_2 and D_3 represents the safety margin which is needed to protect the internal electrodes.

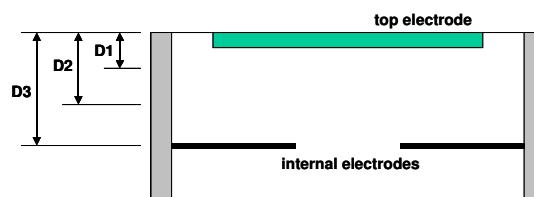

The recommended settings for an uncharacterized laser are: rep-rate 1kHz, beam speed 20mm/s, average power 1W and scan-in increment $12.5\mu\text{m}$. Laser manufacturers are ESI, Hitachi, US Laser Corp, California Digital, Robotics, Sihon and Cheval Frères for instance.