

LEPCOS (North-West Laboratory)

http://ferrite.ru Tel/fax +7-812-369-11-54
St-Petesburg, Russia

REVISIONS

REV	SYM	DRAFTER	CHECKER	DATE
△2		T.S.LII	W.H.HSU	03/12/03
△3		T.S.LII	W.H.HSU	07/24/06
△4		T.S.LII	W.H.HSU	05/16/07

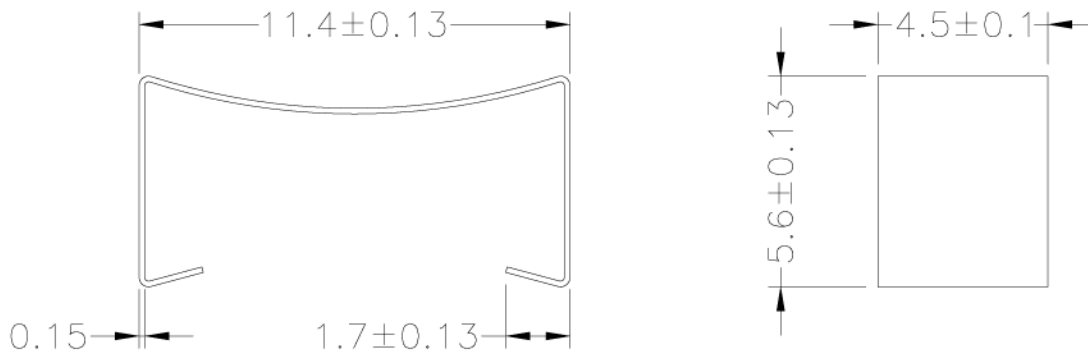
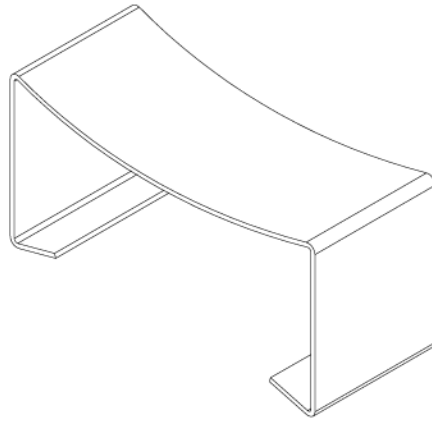

DWG NO. ER11/5 clamp E-009C

PART NO.	MATERIAL (BOBBIN)	MATERIAL (CLIP)	TERMINAL (PLATING)	PIN ALLOCATION	NOTE
E-009C		SUS 301			

TOLERANCE: .X±0.15 .XX±0.10 .XXX±0.05 UNIT : m / m SCALE 5 : 1

Finish: 1. Pb wire Immersion Sn on terminal : Thickness:Sn plating,100,5 μm (200 μ inches) min,Base nickel 0.625 μm (25 μ inches) min.
2. CP wire Immersion Sn on terminal : Thickness:Sn plating,100,5 μm (200 μ inches) min.
3. Coplanarity deviation: 0.10 mm (0.004 inches)max.

REV 4