

Description

The DFS05HF12EYR1 is a half bridge SiC MOSFET Power Module. It integrates high performance SiC MOSFET chips designed for the applications such as Solar Inverter Systems, Fuel cell-DC/DC converter, Uninterruptible Power Supplier, Energy Storage Systems.



Features

- Blocking voltage:1200V
- 5.5mΩ $R_{ds(on)}$
- Low Switching Losses
- 175°C maximum junction temperature
- Si₃N₄ AMB
- Thermistor inside

Applications

- Solar inverter Systems
- Fuel cell-DC/DC converter
- Uninterruptible Power Supplier
- Energy Storage Systems

Circuit diagram

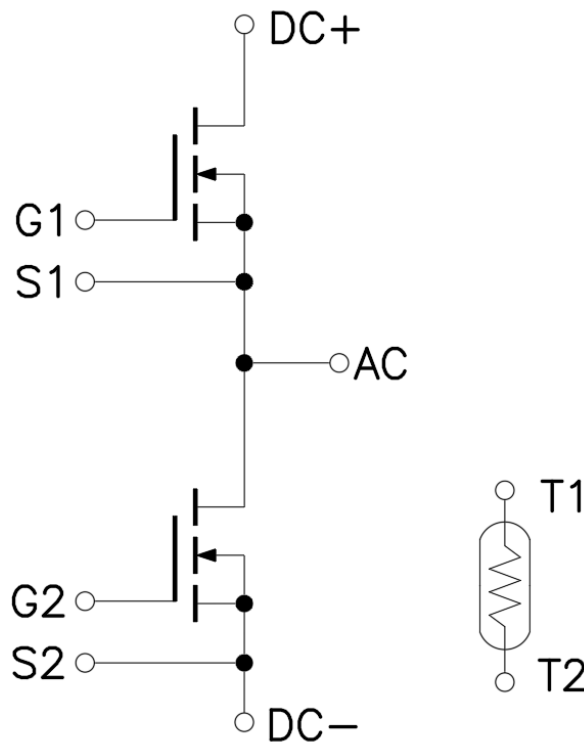

Figure 1. Out drawing & circuit diagram for DFS05HF12EYR1

Pin Configuration and Marking Information

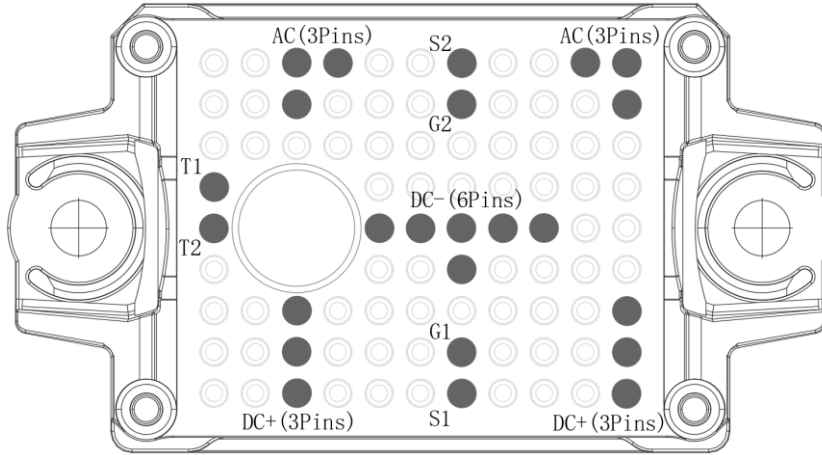

Figure 2. Pin configuration

Symbol	Description
AC	Output terminal of half bridge
S2	Low side source signal terminal
G2	Low side gate signal terminal
DC+	DC+ Bus connection
DC-	DC- Bus connection
S1	High side source signal terminal
G1	High side gate signal terminal
T1	Thermistor connection 1
T2	Thermistor connection 2

Module

Parameter	Conditions	Value	Unit
Isolation voltage	RMS, f=50Hz, t=1min	3.4	kV
Clearance	Terminal to Terminal	5	mm
	Terminal to Heatsink	10	mm
Creepage distance	Terminal to Terminal	6.3	mm
	Terminal to Heatsink	12.7	mm
Comparative Tracking Index	-	600	-
Weight	-	26	g

Maximum Ratings (T_j=25°C unless otherwise specified)

Symbol	Parameter	Conditions	Ratings	Unit
V _{DSS}	Drain-Source Voltage	G-S Short	1200	V
V _{GSS}	Gate-Source Voltage(+)	D-S Short	21	V
V _{GSS}	Gate-Source Voltage(-)	D-S Short	-2	V
V _{GSSSurge}	G-S Voltage(t _{surge} <300nsec)	D-S Short, Note1	-6 to 23	V
I _{DS}	DC Continuous Drain Current	T _f =95°C, Note2	150	A
I _{SD}	Source (Body diode) Current	T _f =95°C, with ON signal	150	A
I _{DP}	Drain Pulse Current, Peak	Less than 1ms, Note3	400	A
T _j	junction temperature	-	-40 to 175	°C
T _{stg}	Storage temperature	-	-40 to 125	°C

Note1: Recommended Operating Value, +18V/0V.

Note2: Case temperature(T_c) is defined on the surface of base plate just under the chips.

Note3: Pulse width limited by maximum junction temperature

NTC characteristics

Symbol	Parameter	Condition	Value			Unit
			Min.	Typ.	Max.	
R ₂₅	Resistance	T _c =25°C	-	5	-	kΩ
ΔR/R	Deviation of R100	T _c =100°C, R ₁₀₀ =493Ω	5	-	5	%
P ₂₅	Power dissipation	T _c =25°C	-	-	20	mW
B _{25/50}	B-value	R ₂ =R ₂₅ exp [B _{25/50} (1/T ₂ - 1/(298,15 K))]	-	3375	-	K
B _{25/80}	B-value	R ₂ =R ₂₅ exp [B _{25/80} (1/T ₂ - 1/(298,15 K))]	-	3411	-	K
B _{25/100}	B-value	R ₂ =R ₂₅ exp [B _{25/100} (1/T ₂ - 1/(298,15 K))]	-	3433	-	K

MOSFET Electrical characteristics (T_j=25°C unless otherwise specified, chip)

Symbol	Item	Condition	Value			Unit	
			Min.	Typ.	Max		
V _{(BR)DSS}	Drain-Source Breakdown Voltage	V _{GS} =0V, I _D =1mA	1200	-	-	V	
I _{DSS}	Zero gate voltage drain current	V _{DS} =1200V, V _{GS} =0V	-	-	160	μA	
V _{GS(th)}	Gate-source threshold voltage	I _D =73mA, V _{DS} =V _{GS}	2.8	-	4.8	V	
I _{GSS+}	Gate-Source Leakage Current	V _{GS} =21V, V _{DS} =0V, T _j =25°C	-	-	200	nA	
I _{GSS-}		V _{GS} =-2V, V _{DS} =0V, T _j =25°C	-200	-	-	nA	
R _{DS(on)} (Chip)	Static drain-source	I _D =150A V _{GS} =+18V	T _j =25°C	-	5.5	6.9	mΩ
	On-state resistance		T _j =175°C	-	13	-	mΩ
V _{DS(on)} (Chip)	Static drain-source	I _D =150A V _{GS} =+18V	T _j =25°C	-	0.83	1.04	V
	On-state voltage		T _j =175°C	-	1.95	-	V
C _{iss}	Input capacitance	V _D =10V, V _{GS} =0V, f =200kHz	-	14.5	-	nF	
C _{oss}	Output capacitance		-	0.4	-	nF	
C _{rss}	Reverse transfer capacitance		-	0.03	-	nF	
Q _G	Total gate charge	V _{DD} =600V, I _D =150A, V _{GS} =+15/0V	-	520	-	nC	
R _{Gint}	Internal Gate Resistance	T _j =25°C	-	1.9	-	Ω	
t _{d(on)}	Turn-on delay time	V _{DD} =600V I _D =150A V _{GS} =+18/0V R _G =3.3Ω Inductive load switching operation	T _j =25°C	-	58	-	ns
			T _j =150°C	-	55	-	
t _r	Rise time		T _j =25°C	-	27	-	ns
			T _j =150°C	-	18	-	
t _{d(off)}	Turn-off delay time		T _j =25°C	-	245	-	ns
			T _j =150°C	-	290	-	
t _f	Fall time		T _j =25°C	-	40	-	ns
			T _j =150°C	-	43	-	
E _{on}	Turn-on power dissipation		T _j =25°C	-	3.54	-	mJ
			T _j =150°C	-	3.35	-	
E _{off}	Turn-off power dissipation	T _j =25°C	-	1.59	-	mJ	
		T _j =150°C	-	1.76	-		
R _{th(j-c)}	FET Thermal Resistance	Junction to Case/MOSFET	-	0.12	-	K/W	
R _{th(c-f)}	Contact thermal resistance	With thermal conductive grease/MOSFET	-	0.15	-	K/W	

Assumes Thermal Conductivity of grease is 2.8 W/m·K and thickness is 50um.

Body Diode Electrical characteristics (T_j=25°C unless otherwise specified, chip: Target)

Symbol	Item	Condition	Value			Unit	
			Min.	Typ.	Max.		
V _{SD}	Body Diode Forward Voltage	V _{GS} =0V I _{SD} =150A	T _j =25°C	-	3.3	-	V
			T _j =150°C	-	4.0	-	
T _{rr}	Reverse recovery time	V _{DD} =600V I _D =150A	T _j =25°C	-	41.5	-	ns
			T _j =150°C	-	45	-	
Q _{rr}	Reverse recovery charge	V _{GS} =+18/0V R _G =3.3Ω	T _j =25°C	-	2.19	-	μC
			T _j =150°C	-	3.94	-	
E _{rr}	Diode switching power dissipation	Inductive load switching operation	T _j =25°C	-	0.64	-	mJ
			T _j =150°C	-	1.42	-	

Test Conditions

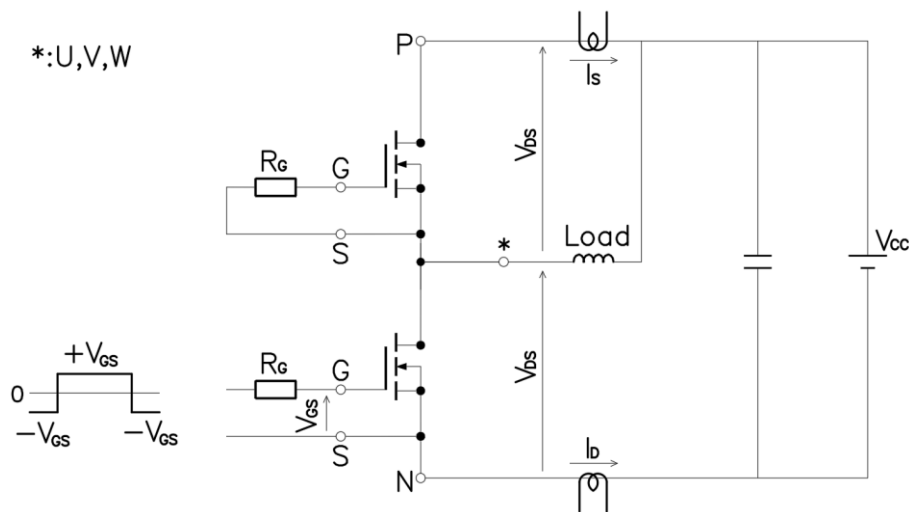

Figure 3. Switching time measure circuit

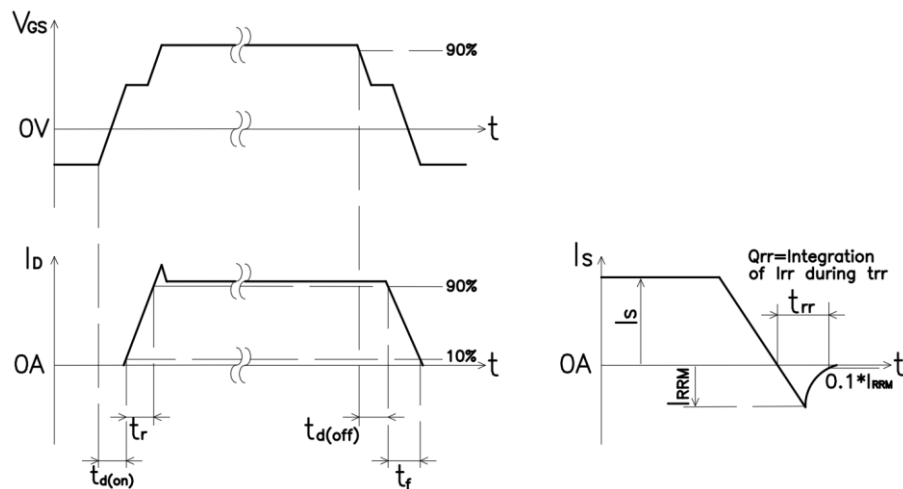

Figure 4. Switching time definition

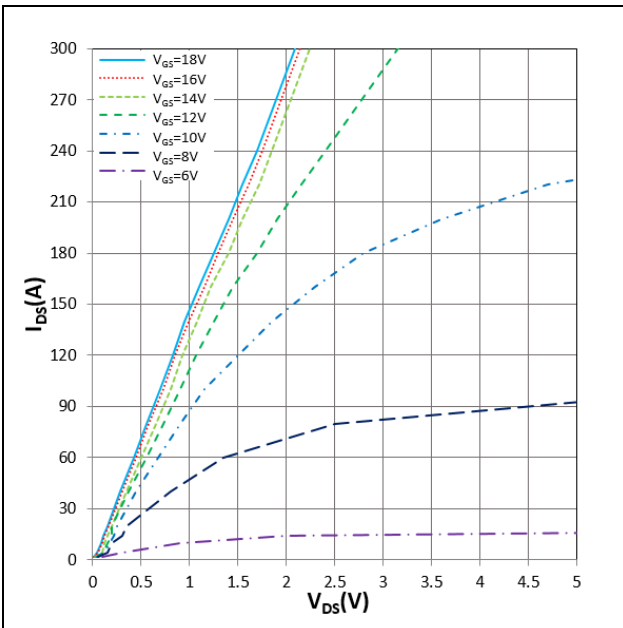

Figure 5. I_{DS} vs V_{DS}
 $T_j = 25^\circ\text{C}$, V_{GS} parameter

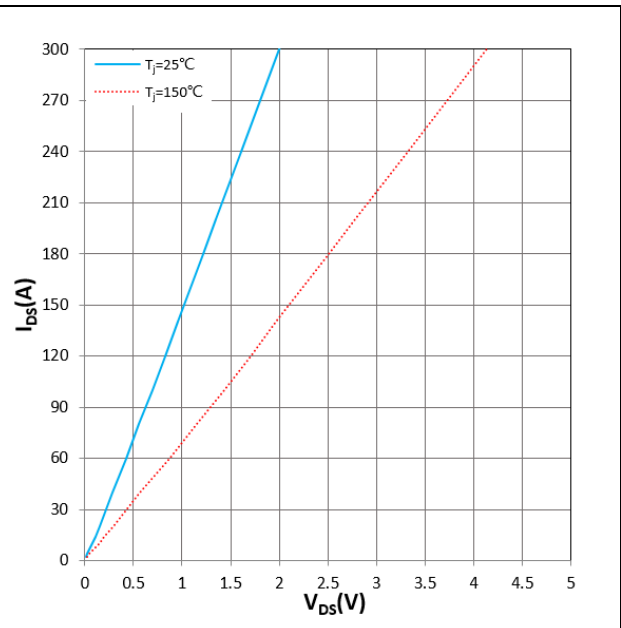

Figure 6. I_{DS} vs V_{DS}
 $V_{GS} = +18\text{V}$

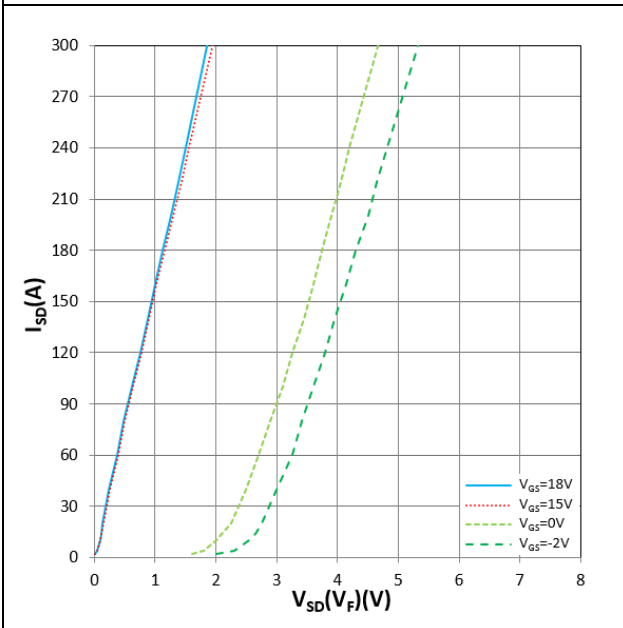

Figure 7. I_{SD} vs $V_{SD}(V_F)$
 $T_j = 25^\circ\text{C}$, V_{GS} parameter

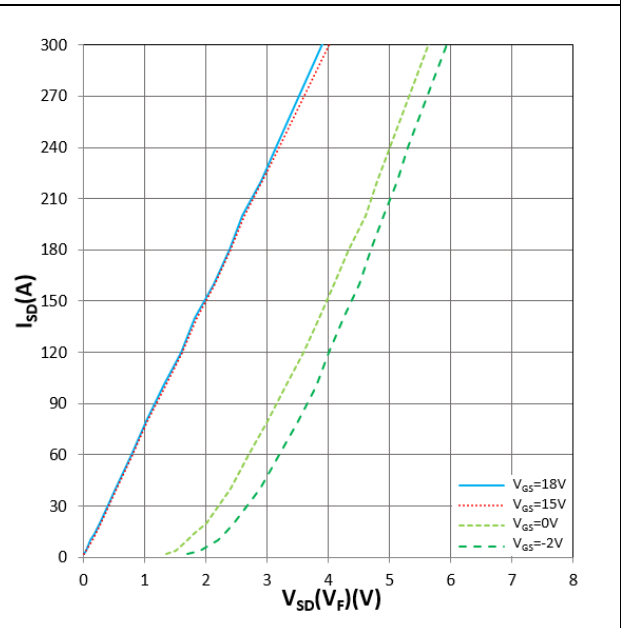

Figure 8. I_{SD} vs $V_{SD}(V_F)$
 $T_j = 150^\circ\text{C}$, V_{GS} parameter

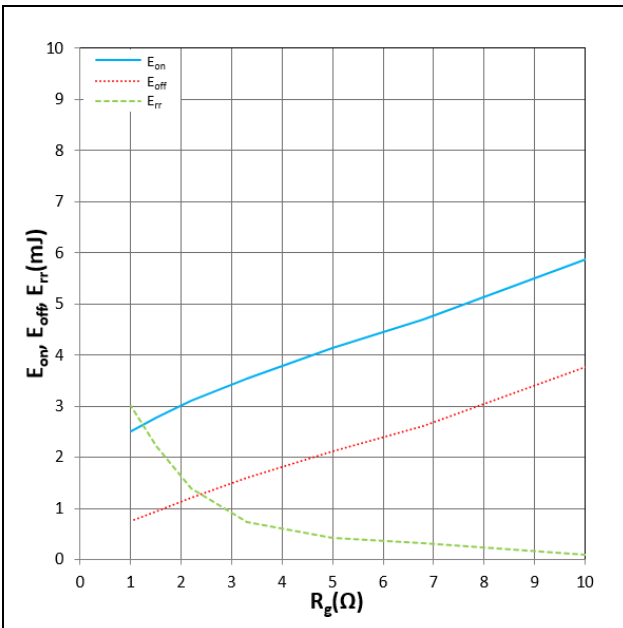

Figure 9. E_{on} , E_{off} , E_{rr} vs R_G
 $T_j=25^\circ\text{C}$, $I_D=150\text{A}$, $V_{GS}=+18\text{V}/0\text{V}$

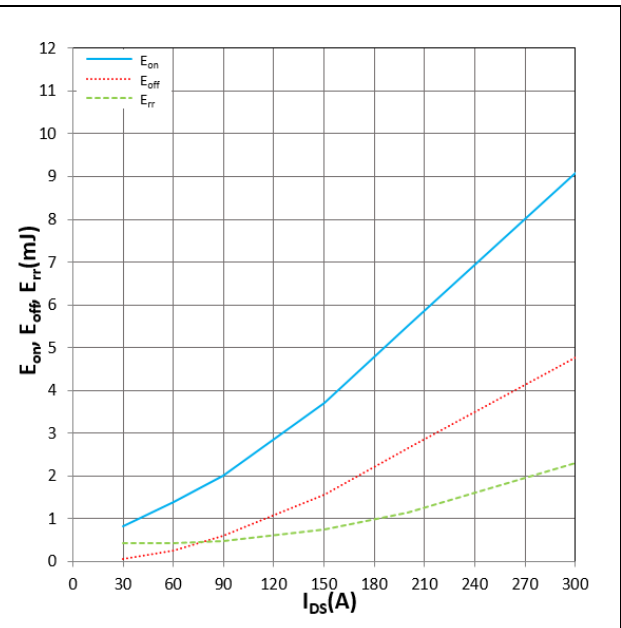

Figure 10. E_{on} , E_{off} , E_{rr} vs I_{DS}
 $T_j=25^\circ\text{C}$, $R_G=3.3\Omega$, $V_{GS}=+18\text{V}/0\text{V}$

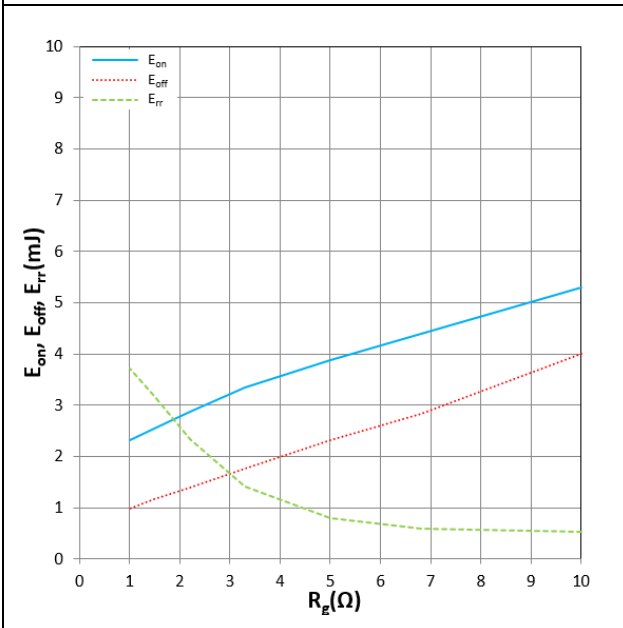

Figure 11. E_{on} , E_{off} , E_{rr} vs R_G
 $T_j=150^\circ\text{C}$, $I_D=150\text{A}$, $V_{GS}=+18\text{V}/0\text{V}$

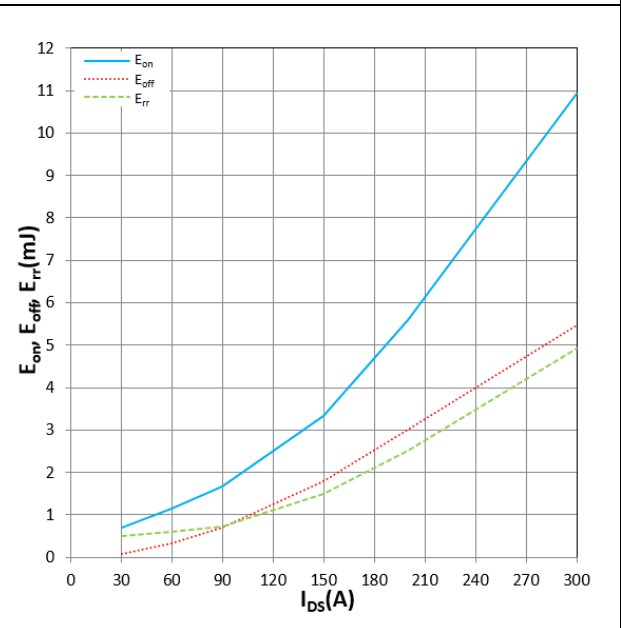
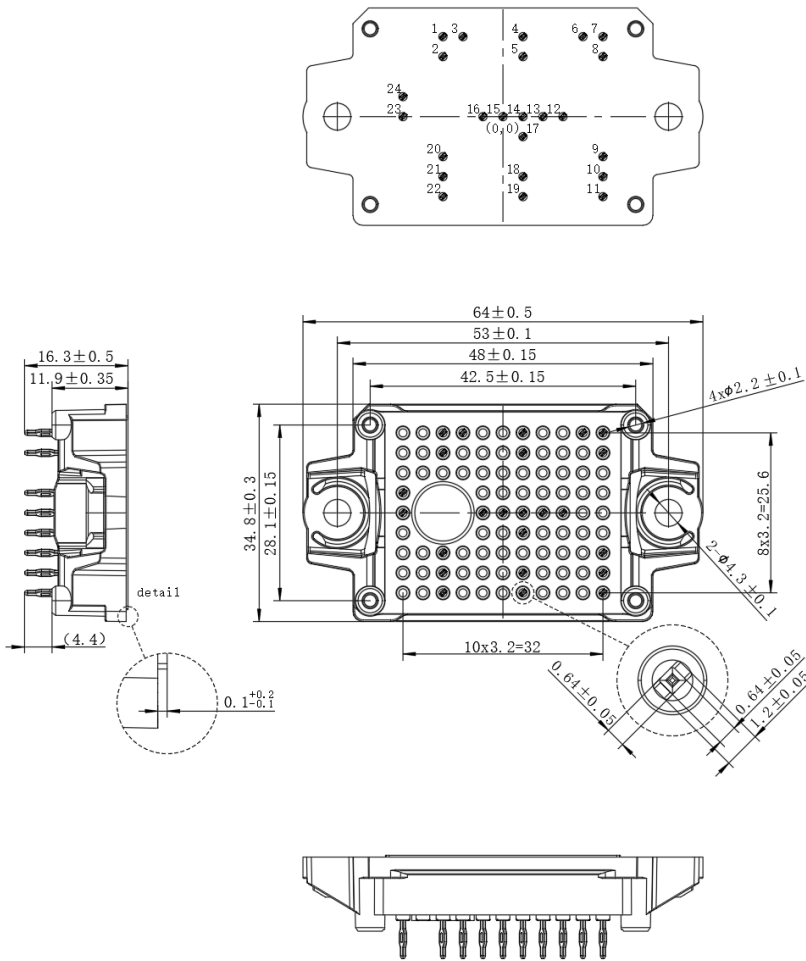

Figure 12. E_{on} , E_{off} , E_{rr} vs I_{DS}
 $T_j=150^\circ\text{C}$, $R_G=3.3\Omega$, $V_{GS}=+18\text{V}/0\text{V}$

Package dimensions



Pin table		
Pin	X	Y
1	-9.6	12.8
2	-9.6	9.6
3	-6.4	12.8
4	3.2	12.8
5	3.2	9.6
6	12.8	12.8
7	16	12.8
8	16	9.6
9	16	-6.4
10	16	-9.6
11	16	-12.8
12	9.6	0
13	6.4	0
14	3.2	0
15	0	0
16	-3.2	0
17	3.2	-3.2
18	3.2	-9.6
19	3.2	-12.8
20	-9.6	-6.4
21	-9.6	-9.6
22	-9.6	-12.8
23	-16	0
24	-16	3.2

IMPORTANT NOTICE

This product data sheet describes the characteristics of this product for which a warranty is granted. Any such warranty is granted exclusively under the terms and conditions of the supply agreement. There will be no guarantee or of any kind for the product and its characteristics.

The data contained in this document is exclusively intended for technically trained staff. You and your technical departments will have to evaluate the product's suitability for the intended application and the completeness of the product data concerning such application.

Due to technical requirements, our product may contain dangerous substances. For information on the types in question, please contact the sales staff responsible for you.

Changes to this product data sheet are reserved.

Please contact the sales staff (Sales@leapers-power.com) for further information on the product, technology, delivery terms, conditions and prices.