

LEPCOS (North-West Laboratory)

http://ferrite.ru Tel/fax +7-812-369-11-54
St-Petesburg, Russia

REVISIONS

REV	SYM	DRAFTER	CHECKER	DATE
2		S.Y.TANG	S.M.SHIH	12/25/06
3		S.Y.TANG	W.H.HSU	04/19/07
4		S.Y.TANG	W.H.HSU	08/05/07

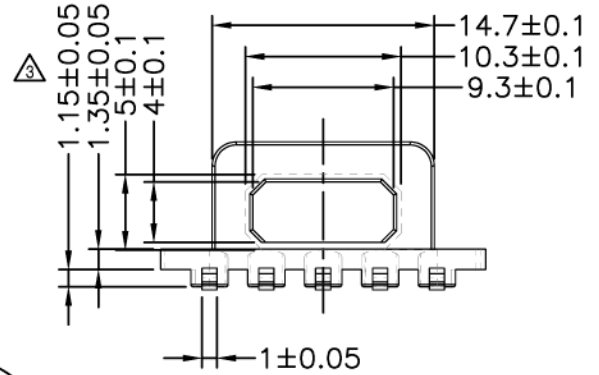
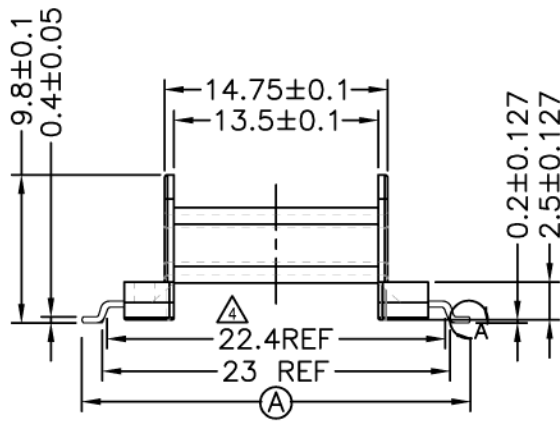
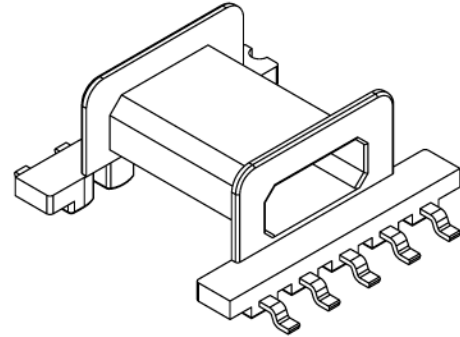
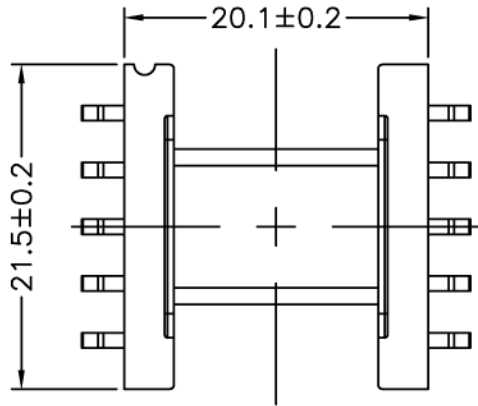

DETAIL:A
PATENTED

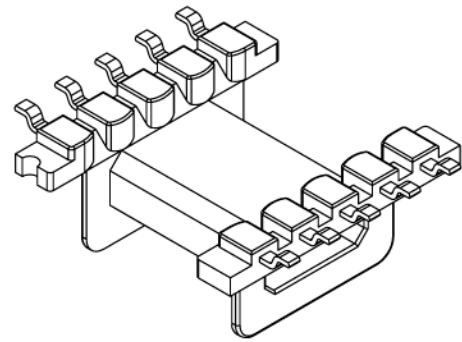
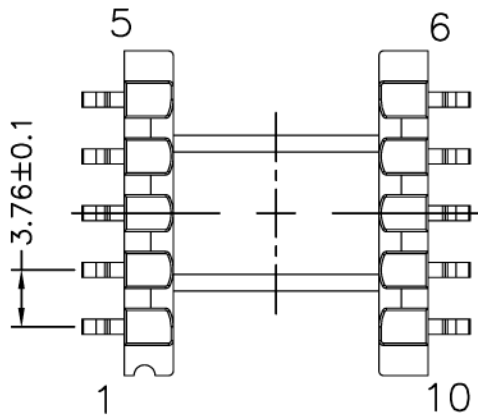

DWG NO. EFD20 Bobbin 1 sec 10 pin SMD E-066

PART NO.	MATERIAL (BOBBIN)	MATERIAL (TERMINAL)	TERMINAL (PLATING)	PIN ALLOCATION	NOTE
----------	-------------------	---------------------	--------------------	----------------	------

2	E-066	PM-9630 JT	P.B	Sn	ALL PIN(A) = 25.08 ± 0.2
---	-------	------------	-----	----	--------------------------

TOLERANCE:	.X ± 0.15	.XX ± 0.10	.XXX ± 0.05	UNIT : m / m	SCALE 2 : 1
------------	-----------	------------	-------------	--------------	-------------

Finish: 1. Pb wire Immersion Sn on terminal : Thickness: Sn plating, 100,5 μm (200 μ inches) min, Base nickel 0.625 μm (25 μ inches) min.
2. CP wire Immersion Sn on terminal : Thickness: Sn plating, 100,5 μm (200 μ inches) min.
3. Coplanarity deviation: 0.10 mm (0.004 inches) max.

REV 4