

1. Main content and apply scope

This document defined the requirements of electrolytic capacitor about technical parameters, test method and application. In reference to this file about the product testing and quality judgment and new product development, described as follows:

Operating temperature range means the capacitor under the application of rated voltage condition, can work reliably time.

Unless otherwise specified, the measurement should be conducted under the following conditions:

Temperature:15~35℃;

relative humidity:45~85%;

atmospheric pressure:86Kpa~106Kpa;

If the test result are undeterminable, it should be measured under the following conditions:

temperature:20±2℃

relative humidity:60~70%

atmospheric pressure:86Kpa~106Kpa

2. Main parameter

Category Temperature Range	-40~+85℃
Capacitance (20℃, 120Hz)	4700(±20%)μF
Rated Voltage	400V
Surge Voltage	450V
Rated Ripple Current (40℃, 120Hz)	8.1Arms
Leakage Current (20℃, 5min)	≤0.01CV or 5mA, Whichever is smaller(μA), [C:Nominal Capacitance(μF),V:Rated voltage]
Dissipation Factor	≤0.15
Size (D×L) mm	76×105
Reference Standard/Others	JISC 5101-4

3. Characteristics

No.	Item	Characteristics
3.1	Capacitance	Test Frequency: 120Hz±12Hz Test Voltage : ≤ 0.5Vrms +1.5~2.0V.DC Test Temperature: 20±2℃ Tolerance capacitance: see the table 2.
3.2	Leakage Current	Test condition and standard:See the table 2.
3.3	Dissipation Factor	Test condition is the same with capacitance: See the table 2.

TMCE21 Screw Terminal Aluminum Electrolytic Capacitor

3.4	Surge Voltage	<p>Under the temperature 15 ~ 35°C, series a resistance 1KΩ and applied the surge voltage with the Period: Within 6±0.5minutes, 30±5 seconds charged and then self-discharged, about 1000times. After the temperature returned to 20°C, the capacitor must meet the specification :</p> <table border="1" style="width: 100%; border-collapse: collapse;"> <tr> <td style="width: 50%;">Leakage Current</td> <td>Not more than specified value</td> </tr> <tr> <td>Capacitance change</td> <td>Within ±15% of the initial value</td> </tr> <tr> <td>Dissipation Factor</td> <td>Not more than 200% of specified value</td> </tr> <tr> <td>Appearance</td> <td>Should not significantly be changed no leakage</td> </tr> </table>	Leakage Current	Not more than specified value	Capacitance change	Within ±15% of the initial value	Dissipation Factor	Not more than 200% of specified value	Appearance	Should not significantly be changed no leakage
Leakage Current	Not more than specified value									
Capacitance change	Within ±15% of the initial value									
Dissipation Factor	Not more than 200% of specified value									
Appearance	Should not significantly be changed no leakage									
3.5	Shelf life	<p>Storage without voltage applied at 85°C for 1000 hours and measured at 25 ±5°C, UR to be applied for 30 minutes, 24 to 48 hours before measurement:</p> <table border="1" style="width: 100%; border-collapse: collapse;"> <tr> <td style="width: 50%;">Leakage Current</td> <td>Not more than 200% of specified value</td> </tr> <tr> <td>Capacitance change</td> <td>Within ±20% of the initial value</td> </tr> <tr> <td>Dissipation Factor</td> <td>Not more than 200% of specified value</td> </tr> </table>	Leakage Current	Not more than 200% of specified value	Capacitance change	Within ±20% of the initial value	Dissipation Factor	Not more than 200% of specified value		
Leakage Current	Not more than 200% of specified value									
Capacitance change	Within ±20% of the initial value									
Dissipation Factor	Not more than 200% of specified value									
3.6	Endurance	<p>According IEC60384-4No.4.13, with rate voltage and ripple current at 85±2°C for 12000 hours, After the temperature returns to 20°C storage 24 to 48 hours before measurement, the capacitor must meet the specification :</p> <table border="1" style="width: 100%; border-collapse: collapse;"> <tr> <td style="width: 50%;">Leakage Current</td> <td>Not more than specified value</td> </tr> <tr> <td>Capacitance change</td> <td>Within ±20% of the initial value</td> </tr> <tr> <td>Dissipation Factor</td> <td>Not more than 200% of specified value</td> </tr> </table>	Leakage Current	Not more than specified value	Capacitance change	Within ±20% of the initial value	Dissipation Factor	Not more than 200% of specified value		
Leakage Current	Not more than specified value									
Capacitance change	Within ±20% of the initial value									
Dissipation Factor	Not more than 200% of specified value									
3.7	Endurance against Vibration	<p>Vibration Frequency Range: 10~55Hz; Total Amplitude: 1.5mm; Rate of Scanning: 10-55-10Hz about 1 minute Vibration direction and time: X-Y-Z 2hours for each direction, total 6hours.</p> <table border="1" style="width: 100%; border-collapse: collapse;"> <tr> <td style="width: 50%;">Appearance</td> <td>Should not significantly be changed</td> </tr> <tr> <td>Capacitance change</td> <td>Within ±5% of the initial value</td> </tr> </table>	Appearance	Should not significantly be changed	Capacitance change	Within ±5% of the initial value				
Appearance	Should not significantly be changed									
Capacitance change	Within ±5% of the initial value									
3.8	Pressure Relief Vent Performance	<p>Apply 10A DC reverse current, in 30 minutes, pressure relief vent should properly function and metal pieces should not be dispersed, there are no irregularities.</p>								

5. Dimensions

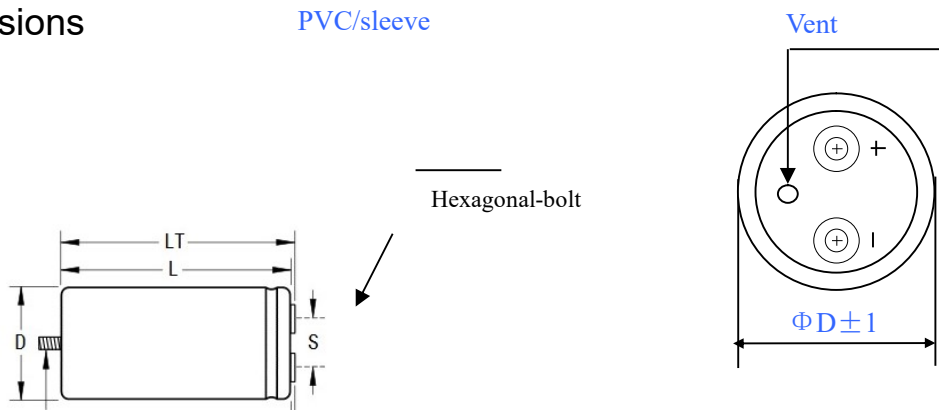

LT±2 D±1

Terminal Size

Terminal type	Diameter (D)	Distance of terminal(P)	Screw Thread	Diameter of terminal	Height of terminal(T)	With Stud (M12)
M6	76	32	M6	10	5	12mm*16mm

6. Marking

Name of Brand : TOPMAY
 Series:
 Color of sleeve: Black
 Color of marking: White
 Rated Voltage: 400VDC
 Rated Capacitance: 4700UF
 Surge Voltage: 450VDC



Polarity

7. Structure of the cap

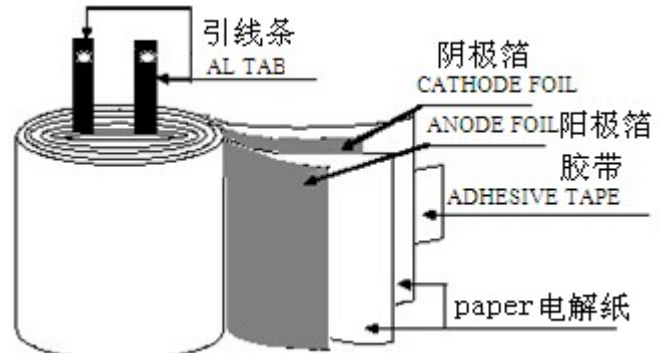
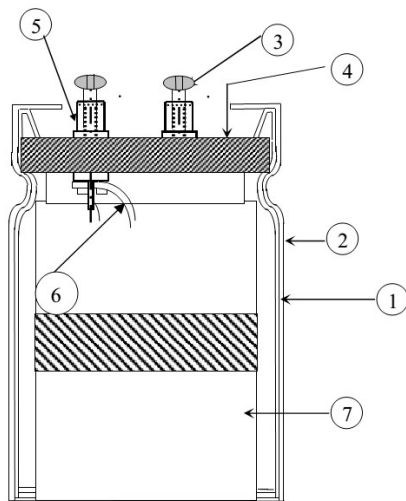

No.	Material	Type
1	Can	Al 99.5%
2	Sleeve/Bottom disc	PVC/PET
3	rivet	Al
4	Cover disc	phenolic resin
5	Anode foil	Al
6	Cathode foil	Al
7	Tab	Al
8	Paper	paper pulp
9	Electrolyte	Glycol+organic acid salt

8. This product is in full compliance with RoHS Directive.

