

LEPCOS (North-West Laboratory)

http://ferrite.ru Tel/fax +7-812-369-11-54
St-Petersburg, Russia

REVISIONS

REV	SYM	DRAFTER	CHECKER	DATE
4		T.S.LII	W.H.HSU	12/27/04
5		T.S.LII	W.H.HSU	06/06/05
6		T.S.LII	W.H.HSU	07/19/06

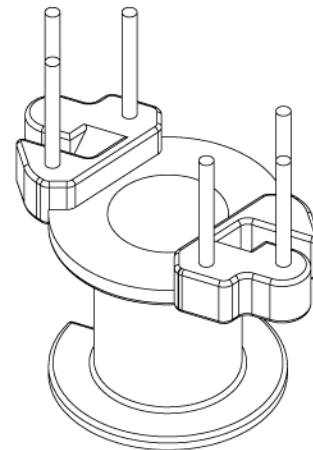
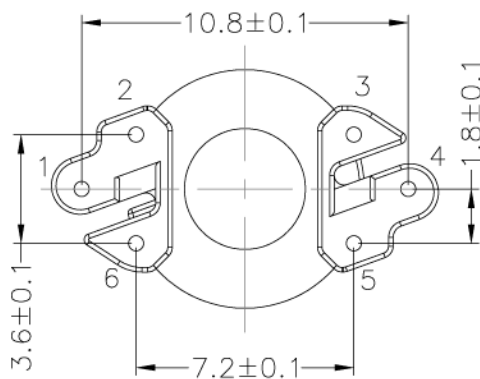
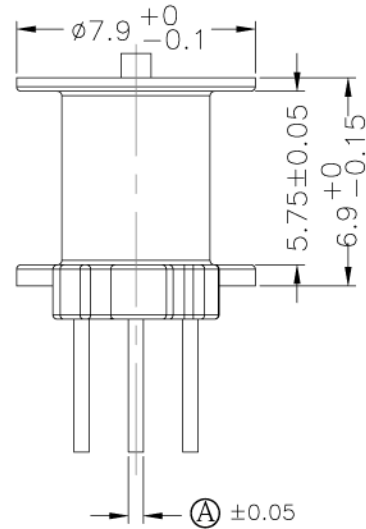
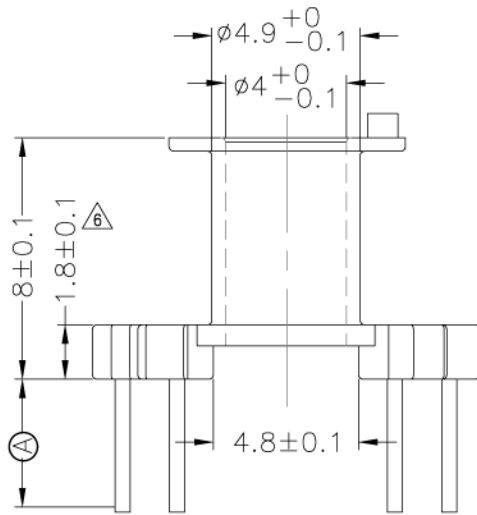
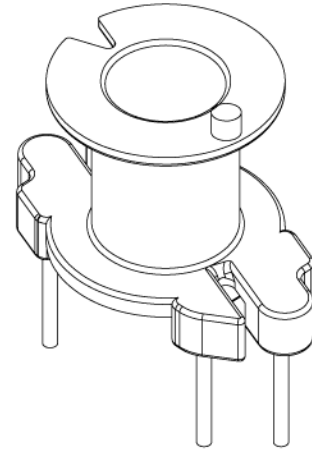
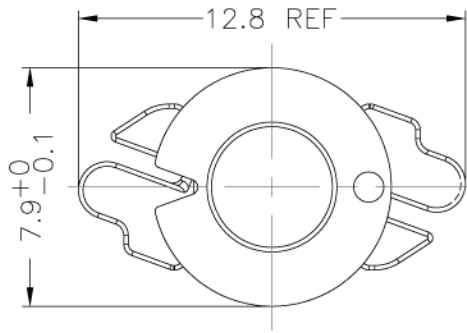

DWG NO. Bobbin RM4 1 sec 6 pin E-041

PART NO.	MATERIAL (BOBBIN)	MATERIAL (TERMINAL)	TERMINAL (PLATING)	PIN ALLOCATION	NOTE
E-041	PM-9630	C.P WIRE	Sn	ALL PIN(A)= \varnothing 0.5(B)=4.4±0.3	

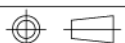

TOLERANCE: .X±0.15 .XX±0.10 .XXX±0.05

UNIT : m / m

SCALE 3 : 1

Finish: 1. Pb wire Immersion Sn on terminal : Thickness:Sn plating,100,5 μm (200 μ inches) min,Base nickel 0.625 μm (25 μ inches) min.
2. CP wire Immersion Sn on terminal : Thickness:Sn plating,100,5 μm (200 μ inches) min.
3. Coplanarity deviation: 0.10 mm (0.004 inches) max.

REV 6