

# CAPXON

## ELECTROLYTIC CAPACITORS

### PRODUCT OVERVIEW

ALUMINUM ELECTROLYTIC CAPACITORS

SOLID CONDUCTIVE POLYMER CAPACITORS

HYBRID CONDUCTIVE POLYMER CAPACITORS







2023/2024

CONTENT

WORLD OF CAPXON		Page
	<b>Our Capacitor Technologies</b>	<b>3</b>
	<b>SMD Aluminum Electrolytic Capacitors</b>	<b>6</b>
	<b>THT Aluminum Electrolytic Capacitors</b>	<b>8</b>
	<b>Snap-In Aluminum Electrolytic Capacitors</b>	<b>15</b>
	<b>Screw Terminal Aluminum Electrolytic Capacitors</b>	<b>20</b>
	<b>SMD Multilayer Solid Conductive Polymer (MLPC)</b>	<b>23</b>
	<b>SMD Solid Conductive Polymer Capacitors</b>	<b>26</b>
	<b>THT Solid Conductive Polymer Capacitors</b>	<b>29</b>
	<b>SMD Hybrid Conductive Polymer Capacitors</b>	<b>32</b>
	<b>THT Hybrid Conductive Polymer Capacitors</b>	<b>36</b>

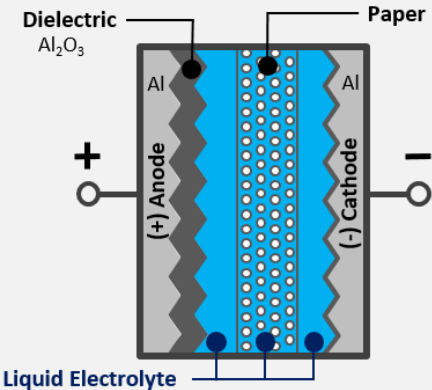
## A WORLD OF ELECTROLYTIC CAPACITORS

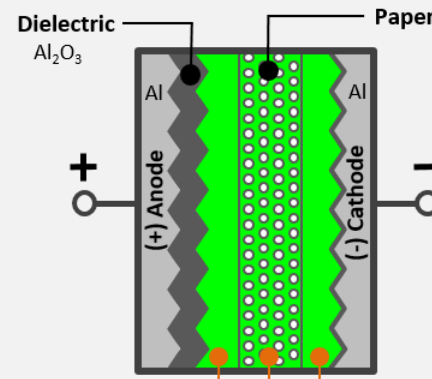
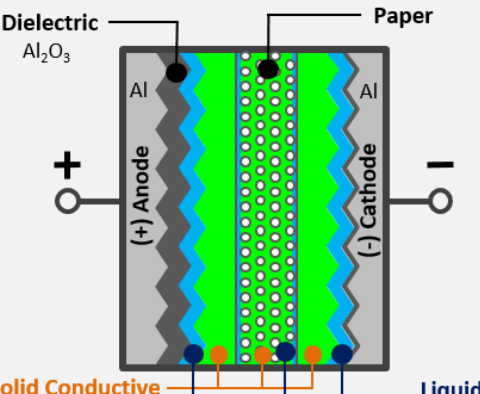
CapXon's know-how in Electrolytic Capacitors covers technologies with aluminum foil. These are Aluminum Electrolytics, Solid Conductive Polymers and the combination known as Hybrid Conductive Polymers:

Aluminum Electrolytic	Description	Features
 <p>Dielectric <math>Al_2O_3</math></p> <p>Paper</p> <p>Al</p> <p>Al</p> <p>(+) Anode</p> <p>(-) Cathode</p> <p>Liquid Electrolyte</p>	<p>Rated Voltage <math>\cdot V_R</math></p> <p>Cathode Material</p> <p>Self-healing of Dielectric</p> <p>Package</p> <p>Stability</p> <p>Lifetime</p> <p>Reliability</p>	<p>4 VDC to 650 VDC</p> <p>Liquid Electrolyte</p> <p>Yes</p> <p>Widest range in all sizes</p> <p>Reduced performance at low temperature</p> <p>Limited life at high temperature</p> <p>Automotive  AEC-Q200 qualified</p>
Solid Conductive Polymer	Description	Features
 <p>Dielectric <math>Al_2O_3</math></p> <p>Paper</p> <p>Al</p> <p>Al</p> <p>(+) Anode</p> <p>(-) Cathode</p> <p>Solid Conductive Polymer</p>	<p>Rated Voltage <math>\cdot V_R</math></p> <p>Cathode Material</p> <p>Self-Healing of Dielectric</p> <p>ESR</p> <p>Stability</p> <p>Lifetime</p> <p>Reliability</p>	<p>2.5 VDC to 100 VDC</p> <p>Solid Conductive Polymer</p> <p>No</p> <p>Ultra-low ESR at high frequency</p> <p>Stable for low and high temperature</p> <p>Very stable and long life - no dry out</p> <p>Only internal standard qualification</p>
Hybrid Conductive Polymer	Description	Features
 <p>Dielectric <math>Al_2O_3</math></p> <p>Paper</p> <p>Al</p> <p>Al</p> <p>(+) Anode</p> <p>(-) Cathode</p> <p>Solid Conductive Polymer</p> <p>Liquid Electrolyte</p>	<p>Rated Voltage <math>\cdot V_R</math></p> <p>Cathode Material</p> <p>Self-Healing of Dielectric</p> <p>ESR</p> <p>Stability</p> <p>Leakage Current <math>\cdot I_{LEAK}</math></p> <p>Reliability</p>	<p>16 VDC to 400 VDC</p> <p>Solid Conductive Polymer &amp; Liquid Electrolyte</p> <p>Yes</p> <p>Very low ESR at high frequency</p> <p>Even more stable than liquid type</p> <p>Lower leakage current than Solid Conductive Polymer Type</p> <p>Automotive  AEC-Q200 qualified</p>

## COMPARISON OF ELECTROLYTIC CAPACITOR TECHNOLOGIES

Characteristics	Aluminum Electrolytic Capacitor	Solid Conductive Polymer Capacitor	Hybrid Conductive Polymer Capacitor
ESR at High Frequency	○ (120 ~ 1 000 mΩ)	++ (7 ~ 15 mΩ)	+ (20 ~ 30 mΩ)
Leakage Current · I <sub>LEAK</sub>	++ (0.01·C <sub>R</sub> ·V <sub>R</sub> )	○ (0.2·C <sub>R</sub> ·V <sub>R</sub> )	++ (0.01·C <sub>R</sub> ·V <sub>R</sub> )
Ripple Current · I <sub>R</sub>	○ (~ 600 mA)	++ (2 000 ~ 7 000 mA)	+ (2 000 ~ 3 000 mA)
Rated Voltage · V <sub>R</sub>	++ (~ 700 V)	○ (~ 100 V)	+ (~ 400 V)
Operating Temperature Characteristics	+ (-40 ~ + 125 °C)	+ (-55 ~ + 125 °C)	++ (-55 ~ + 150 °C)
Low Temperature Characteristics	○ (-40 ~ + 125 °C)	++ (-55 ~ + 125 °C)	+ (-55 ~ + 150 °C)
Lifetime	○ (105 °C / 3 000h)	++ (105 °C / 5 000h)	++ (105 °C / 10 000h)
Failure Mode	+ Open	○ Short	+ Open

++ ... best performance

+ ... well performance

○ ... basic performance

Aluminum Electrolytic Capacitors

# SMD Types

---



### OVERVIEW - SMD ALUMINUM ELECTROLYTIC CAPACITORS



#### Features



Series	Datasheet	AEC-Q200	Bi-Polar	High Temperature	High Voltage	Long Life	Low ESR	Low Leakage	Standard	Ultra Long Life	Ultra Low ESR	Vibration Proof	Temperature Range (°C)	Voltage Range (V)	Capacitance Range (µF)	Endurance (hours)
KV								•					-40 +85	6.3 50	1 330	1000
NV			•										-40 +85	6.3 50	1 560	2000
LV		•		•					•			•	-40 +85	4 450	1 6800	2000
EV		•							•			•	-55 +105	6.3 50	1 1500	1000
HV		•		•	•							•	-55 +105	6.3 100	1 6800	2000
													-40 +105	160 450	2.2 68	
JV		•			•							•	-55 +105	6.3 50	1 1000	3000
DV		•					•					•	-55 +105	6.3 100	1 6800	2000 to 5000
RV		•									•	•	-55 +105	6.3 100	1 6800	2000 to 5000
													-40 +105	160 450	2.2 68	
MV										•			-40 +105	6.3 50	1 1000	5000
CV		•								•	•	•	-40 +105	6.3 50	22 1500	7000
QV	<b>NEW</b>	•								•		•	-25 +105	6.3 50	10 680	10000
TV		•		•								•	-40 +125	10 450	1 330	1000 to 2000
GV	<b>NEW</b>	•		•								•	-55 +150	10 50	33 3300	1000

#### TYPICAL APPLICATIONS

Buffering	Filtering	DC/DC Converters	Miniature Power Supplies	Smoothing

#### ADDITIONAL INFORMATION

For further information on our Aluminum SMD Capacitors, simply click on the symbols in the table below.

General Precautions & Guidelines	Packaging Information	Vibration Test Profiles	3D Models	Reliability Tests	Environmental Declarations

### GROUP CHART • SMD ALUMINUM ELECTROLYTIC CAPACITORS

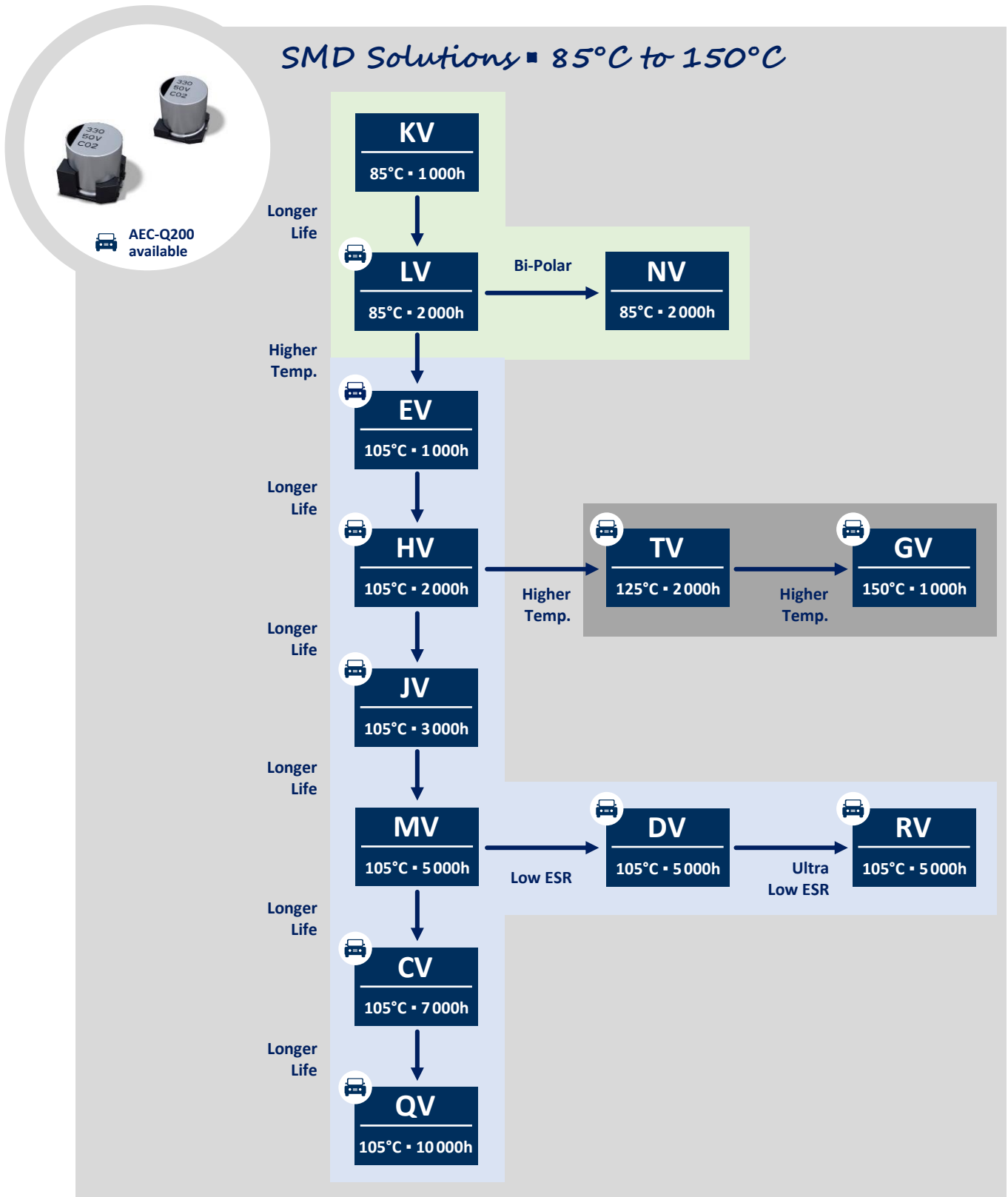

Aluminum Electrolytic Capacitors

# Radial Types

---





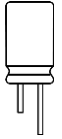

### OVERVIEW - THT ALUMINUM ELECTROLYTIC CAPACITORS

#### Features

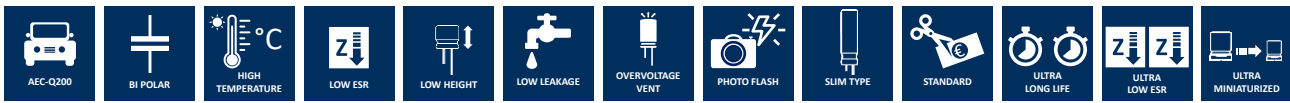

Series	Datasheet	AEC-Q200	Bi-Polar	High Temperature	Low Impedance	Low Height	Low Leakage	Overvoltage Vent	Photo Flash	Slim Type	Standard	Ultra Long Life	Ultra Low Impedance	Ultra Miniaturized	Temperature Range (°C)		Voltage Range (V)		Capacitance Range (µF)		Endurance (hours)
															-	+	-	+	-	+	
RF									•						-20	+55	330	350	100	450	5000 times
SS						•								•	-40	+85	4	50	1	330	1000
SM						•								•	-40	+85	4	63	1	470	1000
SR						•									-40	+85	6.3	50	1	220	1000
SW						•									-40	+85	4	50	1	470	1000
SH						•								•	-40	+85	4	63	1	470	2000
RW											•				-40	+85	6.3	100	1	33000	2000
NR			•												-40	+85	6.3	100	1	1000	2000
GS															-40	+85	6.3	100	1	33000	2000
															-25		160	450	1	560	
NP			•												-40	+85	6.3	100	1	3300	2000
															-25		160	250	1	47	
ST						•								•	-40	+105	4	50	1	220	1000
SK						•								•	-40	+105	4	63	1	470	1000
SZ					•									•	-55	+105	6.3	35	6.8	330	1000
KZ					•										-40	+105	6.3	50	1	6800	1000 to 2000
KS								•							-25	+105	200	400	4.7	400	2000
KY										•					-25	+105	250	450	12	150	2000
KM															-40	+105	6.3	100	1	22000	2000
															-25		160	500	1	560	
NK			•												-40	+105	6.3	100	1	3300	2000
															-25		160	250	1	47	
SJ						•								•	-40	+105	6.3	63	1	220	2000
LL							•								-40	+105	6.3	63	1	2200	2000
LZ													•		-40	+105	6.3	25	220	3300	2000
SY					•	•									-55	+105	6.3	50	1	330	2000

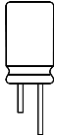

### OVERVIEW - THT ALUMINUM ELECTROLYTIC CAPACITORS

#### Features



Series	Datasheet	AEC-Q200	Bi-Polar	High Temperature	Low Impedance	Low Height	Low Leakage	Overvoltage Vent	Photo Flash	Slim Type	Standard	Ultra Long Life	Ultra Low Impedance	Ultra Miniaturized	Temperature Range (°C)		Voltage Range (V)		Capacitance Range (µF)		Endurance (hours)	
															-40	+105	6.3	100	1	15000		-25
KF					•										-40	+105	6.3	100	1	15000	2000 to 5000	
GF					•										-40	+105	6.3	100	4.7	6800	2000 to 5000	
KC										•			•		-25	+105	400	450	82	220	3000	
SG		•				•							•		-40	+105	6.3	50	1	470	4000	
FH													•		-40	+105	6.3	100	6.8	18000	4000 to 10000	
LY										•					-25	+105	250	450	12	150	5000	
KL		•										•			-40	+105	160	400	3.3	330	5000	
GH		•			•										-55	+105	6.3	100	1	12000	5000 to 10000	
KH																		10	400	6.8	3300	5000 to 10000
																		-25	+105	450	500	
FK		•																160	450	1	330	6000 to 8000
																		-25	+105	500	500	
ZH													•		-40	+105	6.3	100	8.2	8200	6000 to 10000	
FL		•																160	450	1	680	8000 to 12000
																		-25	+105	500	500	
HY										•					-25	+105	250	450	12	120	10000	
GT		•										•			-40	+105	10	100	1	330	10000	
LE												•			-40	+105	160	450	1	68	12000 to 20000	
TH		•		•														10	400	1	8200	1000 to 3000
																		-25	+125	450	450	
TZ	<b>NEW</b>	•		•								•			-40	+125	10	100	4.7	1000	2000 to 5000	
TE		•		•											-40	+130	10	400	2.2	4700	1000 to 3000	
TU	<b>NEW</b>	•		•								•	•		-40	+135	25	100	160	12000	2000 to 3000	

GROUP CHART • THT ALUMINUM ELECTROLYTIC CAPACITORS

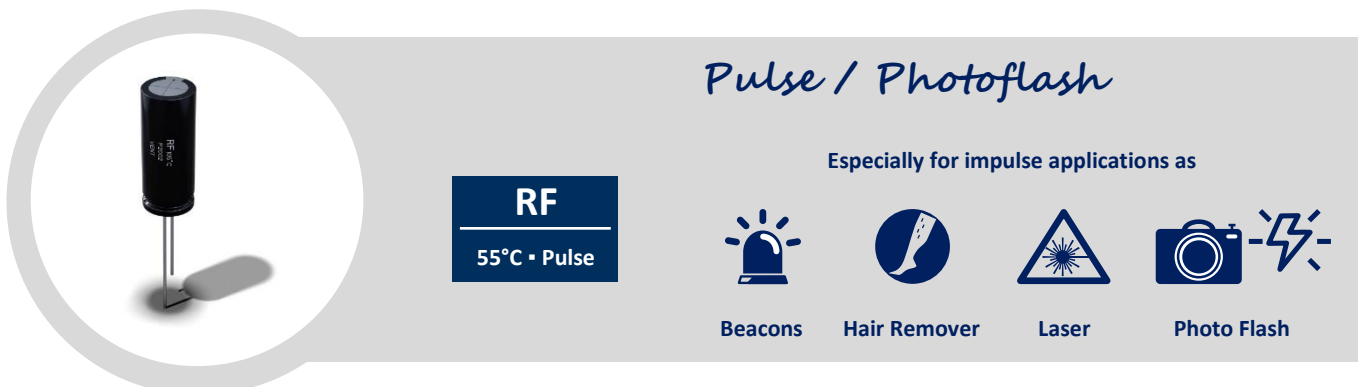
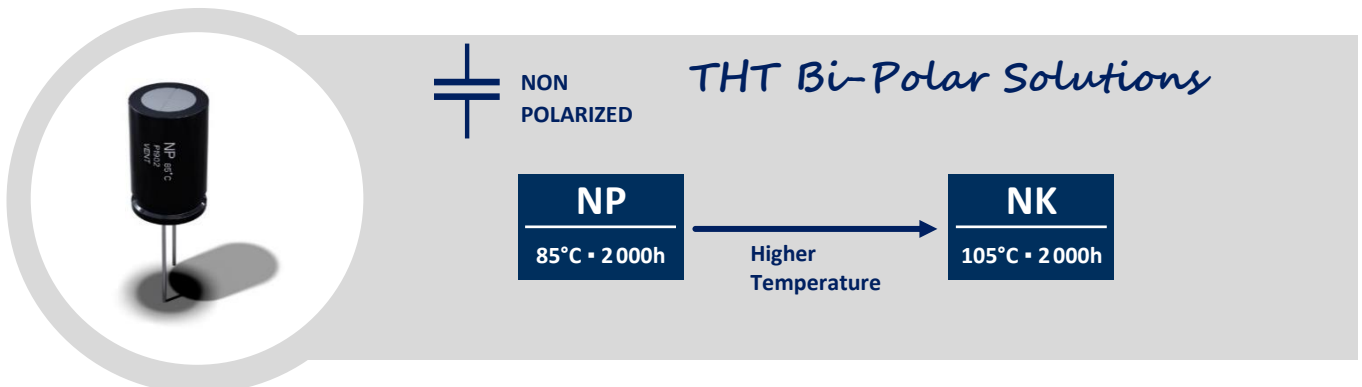
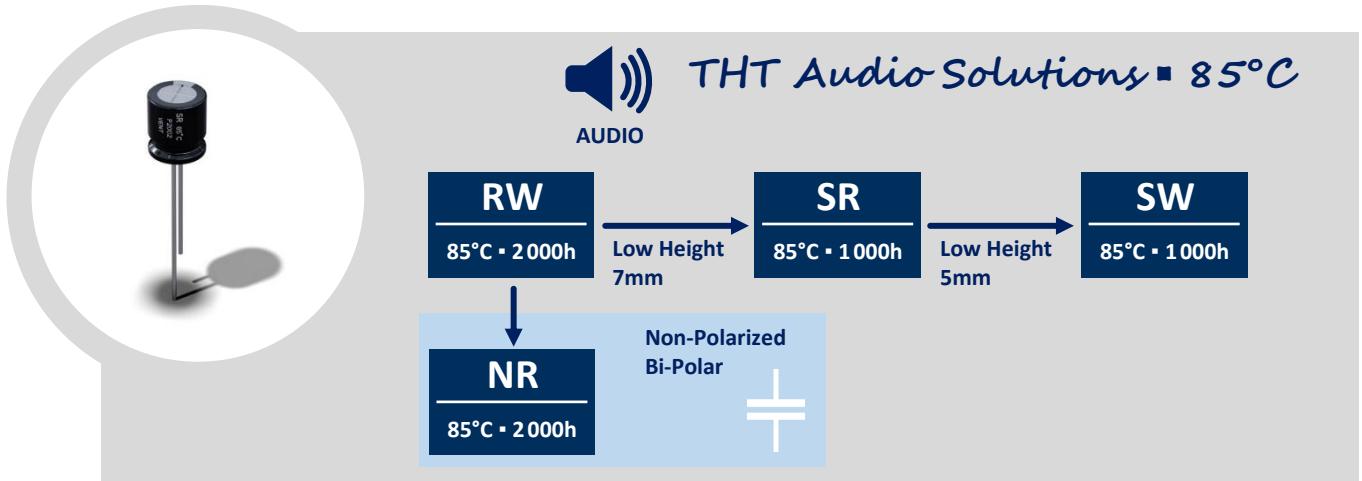
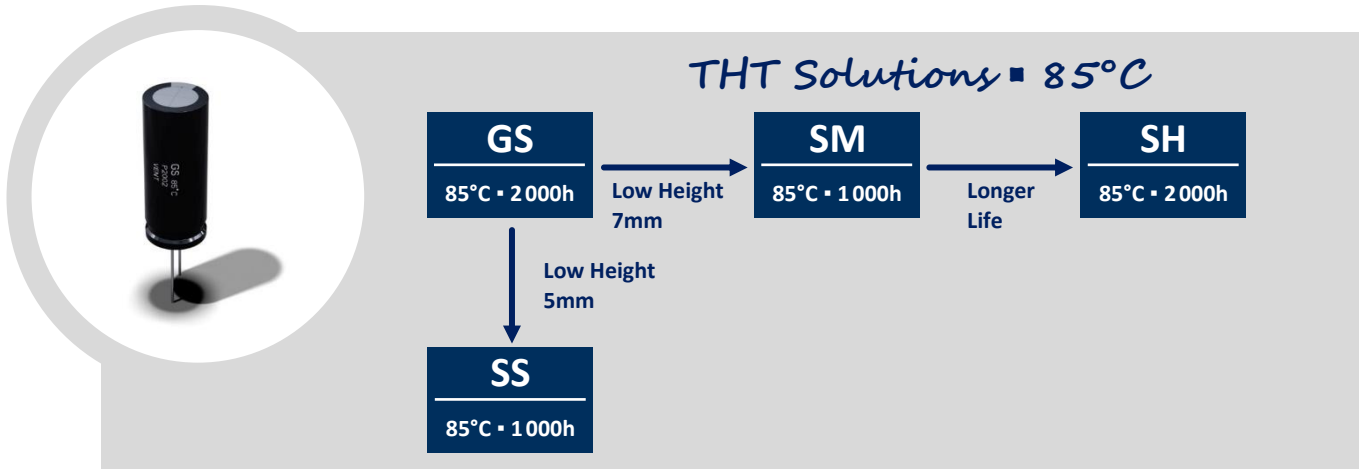

### GROUP CHART • THT ALUMINUM ELECTROLYTIC CAPACITORS

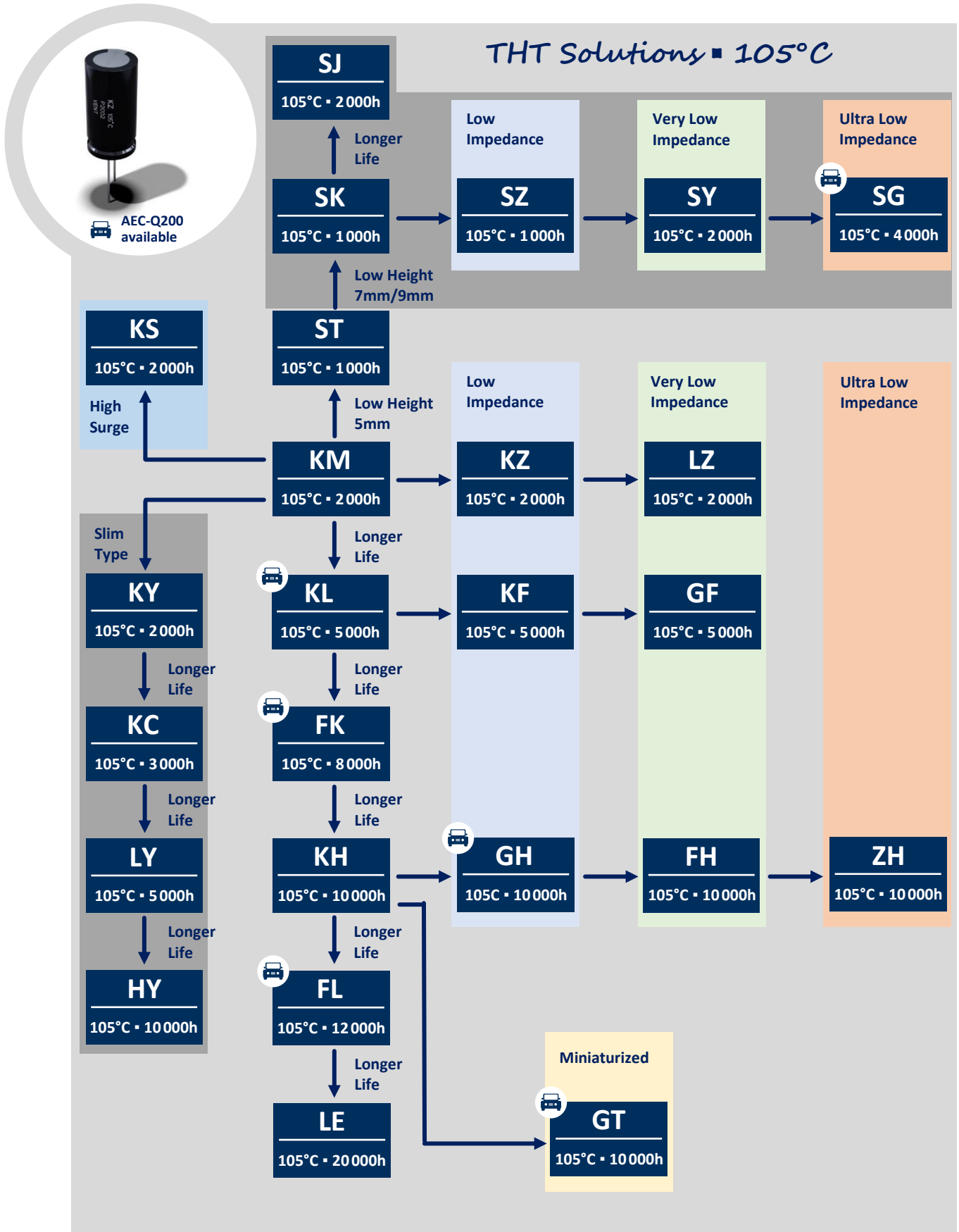

### GROUP CHART • THT ALUMINUM ELECTROLYTIC CAPACITORS

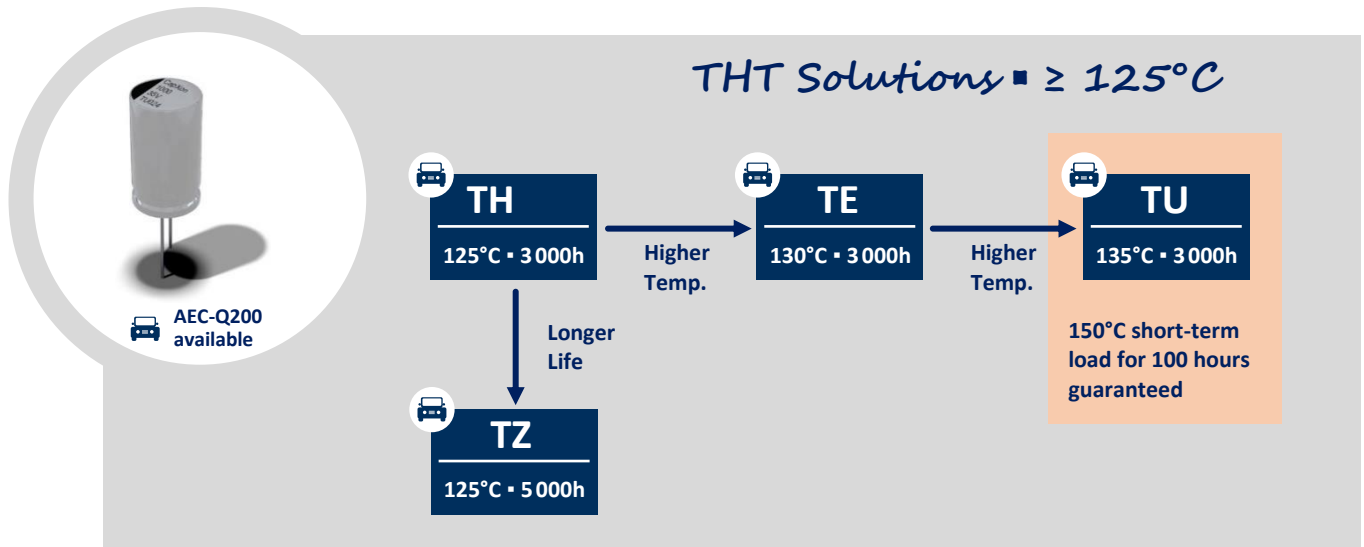

### TYPICAL APPLICATIONS

Buffering	Filtering	DC Linking	Smoothing	Switched Mode Power Supplies



### ADDITIONAL INFORMATION

For further information on our Aluminum THT Capacitors, simply click on the symbols in the table below.

General Precautions & Guidelines	Packaging Information	3D Models	Reliability Tests	Environmental Declarations

### AVAILABLE LEAD TREATMENTS • THT ALUMINUM ELECTROLYTIC CAPACITORS

In addition to the taped versions, the following lead treatments are also possible.  
Please contact your local CapXon representative if you have any further questions.

<b>CA</b>	<b>CE</b>	<b>CF / CG / CH / CI</b>	<b>FA / FE</b>
Cuttled Leads Standard Lead Spacing	Cuttled Leads Wide Lead Spacing $\leq 2.5\text{mm}$	Cuttled Leads Wide Lead Spacing $\geq 2.5\text{mm}$	Wide Lead Spacing $> 5\text{mm}$ Long Anode
			
<b>FB / FC / FD</b>	<b>KA</b>	<b>KE</b>	<b>KF</b>
Wide Lead Spacing $\leq 3.5\text{mm}$ Long Anode	Kinked Anode and Cathode Standard Lead Spacing	Kinked Anode and Cathode Wide Lead Spacing $\leq 2.5\text{mm}$	Kinked Anode and Cathode Wide Lead Spacing $5\text{mm}$
			
<b>EF</b>	<b>CK</b>	<b>JI</b>	<b>CD</b>
Double Kinked Anode and Cathode Lead Spacing $5\text{mm}$	Kinked Anode	Polarity Protected Footprint Cathode Bended	Polarity Protected Footprint Anode Pressed
			
<b>CR</b>	<b>CL</b>	<b>CZ</b>	<b>CS</b>
Bended Leads Cathode Right	Bended Leads Cathode Left	Quasi SMD • Bended Leads Cathode Right	Quasi SMD • Bended Leads Cathode Left
			

Aluminum Electrolytic Capacitors

# Snap In Types

---



### OVERVIEW - SNAP-IN ALUMINUM ELECTROLYTIC CAPACITORS

#### Features

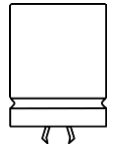

Series	Datasheet	AEC-Q200	High Ripple Current	High Temperature	Low ESR	Long Life	Miniaturized Size	Photo Flash / Pulse	Standard Size	Ultra Long Life	Vibration Proof	Temperature Range (°C)		Voltage Range (V)		Capacitance Range (µF)		Endurance (hours)	Useful Life (hours)
												-	+	-	+	-	+		
SF								•				-20	+55	330	350	150	1500	> 5000 times	
LP									•			-40	+85	6.3	350	100	1mF	2000	3000 to 5000
												-25		385	600	22	2700		
UB									•			-40	+85	200	450	68	3300	2000	5000
												-25		500		100	1500		
UC									•			-40	+85	200	450	68	6800	3000	7000
												-25		500	630	56	1500		
UD						•			•			-40	+85	200	450	68	2700	5000	10000
												-25		500	600	47	680		
HP									•			-40	+105	6.3	350	68	1mF	2000	3000 to 5000
												-25		400	550	47	1200		
UJ		•							•			-40	+105	200	450	82	3300	2000	5000
												-25		500	550	47	1000		
UK		•							•			-40	+105	200	450	68	2200	3000	8000
												-25		500	550	47	680		
UE		•					•					-40	+105	160	450	120	4700	3000	8000
												-25		475	500	68	820		
UA		•	•		•							-40	+105	160	450	56	3300	3000	8000
UL		•				•			•			-40	+105	200	450	82	2700	5000	10000
												-25		500	550	47	680		
UG		•				•	•					-40	+105	400	450	120	1200	5000	10000
												-25		475	500	68	820		
UF		•	•		•	•						-40	+105	200	450	100	2700	5000	10000
												-25		475	500	56	560		
UM		•								•		-40	+105	160	450	47	2200	7000	10000
UH		•								•		-40	+105	200	450	39	1500	10000	12000
HC		•	•	•	•					•	•	-55	+125	25	63	600	3300	3000	4000
HH		•		•						•		-40	+125	400	450	47	560	3000	4000

#### Legend

- Economy Series Not for 24h continuous applications
- High Reliability Series For 7days / 24h continuous applications
- New Product Series For 7days / 24h continuous applications



COMPARISON • ECONOMY GRADE SERIES vs. HIGH RELIABILITY GRADE SERIES

Technical performance, quality control and application area

		Economy Grade		ECONOMY GRADE	High Reliability Grade	HIGH RELIABILITY
CapXon Series		LP • HP			UA • UB • UC • UD • UE • UF • UG • UH • UJ • UK • UM • HC • HH	
Technical Performance	Working voltage and ripple current change	Low	Stable conditions		High	Various changes
	Recommended frequency range	Low	Mains 100/120Hz		Low to High	100/120Hz to several kHz
	Temperature stability	Standard			High	Harsh and outdoor usage
	Leakage current stability (I <sub>LEAK</sub> )	Standard			High	Harsh and outdoor usage
	Dissipation factor (tanδ)	Standard			Low	Lower self-heating
	Impedance (IMP)	Standard			Low	Lower self-heating
	Resistance to ripple current and surge voltage	Standard			High	More resistant to in-rush current and voltage spikes
Quality Control	Stage aging voltage	Short	Electrical parameters within specification value range		Long	Highly uniformity between electrical parameters
	Sorting	Single	Electrical parameters within specification value range		Detailed	Highly uniformity between electrical parameters
Application Area	24 hours continuous operation					•
	Battery chargers	•				
	Frequency converters					•
	Industrial power supplies					•
	Inverter household appliances					•
	Inverter output filtering					•
	Ordinary household appliances	•				
	Outdoor equipment					•
	Rectifier input filtering	•				
	Renewable energy inverters					•
	Servo drives					•
	Standard power supplies	•				
	Uninterruptible power supplies (UPS)					•





### Pulse / Photoflash

**SF**  
 55°C • Pulse

Especially for impulse applications as

  
 Beacons

  
 Hair Remover

  
 Laser

  
 Photo Flash

### 85°C ■ 2000h to 5000h

**LP**  
 85°C • 2000h

**UB**  
 85°C • 2000h

**UC**  
 85°C • 3000h

**UD**  
 85°C • 5000h



■ Economy Type  
Not for 24h continuous operation

### 105°C ■ 2000h to 3000h



 AEC-Q200 available

**HP**  
 105°C • 2000h

**UJ**  
 105°C • 2000h

**UK**  
 105°C • 3000h

■ Economy Type  
Not for 24h continuous operation

■ Miniaturized Size  
■ High Ripple Current

**UE**  
 105°C • 3000h

**UA**  
 105°C • 3000h

### 105°C ■ 5000h to 10000h

**UG**  
 105°C • 5000h

**UF**  
 105°C • 5000h

**UL**  
 105°C • 5000h

**UM**  
 105°C • 7000h

**UH**  
 105°C • 10000h

■ Standard Size   ■ Miniaturized Size   ■ High Ripple Current



 AEC-Q200 available

### 125°C High Reliability



 AEC-Q200 available

**HC**  
 125°C • 3000h

Low Voltage Type  
25V to 63V

  
 HIGH VIBRATION

**HH**  
 125°C • 3000h

High Voltage Type  
400V to 450V

  
 HIGH VOLTAGE





CapXon\_Ver. 005 – 01/08/2023

18

Electrolytics Capacitor Solutions







For further information please contact sales@capxon.org

### TYPICAL APPLICATIONS

Buffering	Filtering	DC Linking	Smoothing	Switched Mode Power Supplies
				

### ADDITIONAL INFORMATION

For further information on our Aluminum Snap-In Capacitors, simply click on the symbols in the table below.

General Precautions & Guidelines	Packaging Information	Vibration Test Profiles	3D Models	Reliability Tests	Environmental Declarations
					

### AVAILABLE TERMINALS - SNAP-IN ALUMINUM ELECTROLYTIC CAPACITORS

Snap-In capacitors are available with the following terminals.

Please contact your local CapXon representative if you have any further questions.

<b>PP</b> 2-Pin Standard Type • ØD = 20 to 45mm	<b>ZP</b> 3-Pin Polarity Protection • ØD = 20 to 45mm	<b>YP</b> Multi-Pin Polarity Protection • ØD = 20 to 45mm
		
<b>LP</b> Slim Terminal ØD = 20 to 45mm	<b>CP</b> Lug Type Robust Terminals • ØD = 30 to 45mm	<b>HP</b> Lug Type Robust Terminals • ØD = 30 to 45mm
		
<b>TP - Right</b> Long Terminal Bended Cathode Right Side • ØD = 20 to 45mm	<b>TP - Left</b> Long Terminal Bended Cathode Left Side • ØD = 20 to 45mm	<b>VP</b> Lug Type for Soldered Wires ØD = 20 to 45mm
		

Aluminum Electrolytic Capacitors

# Screw Types

---



### OVERVIEW - SCREW TERMINAL ALUMINUM ELECTROLYTIC CAPACITORS

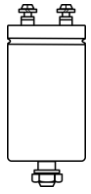

#### Features



Series	Datasheet	High Ripple Current	Long Life	Standard	Ultra Long Life	With Stud	Temperature Range (°C)		Voltage Range (V)		Capacitance Range (µF)		Endurance (hours)	Useful Life (hours)
							-40	+85	10	100	1800	10mF		
RS					•	•	-40	+85	10	100	1800	10mF	2000	12000
RG				•		•	-40	+85	160	450	390	39000	2000	6000
							-25		500	630	1000	10000		
RP		•				•	-40	+85	160	450	270	68000	2000	10000
							-25		500	630	100	10000		
RX					•	•	-40	+85	160	450	220	1mF	5000	20000
							-25		500	630	10000	15000		
RU		•			•	•	-40	+85	160	450	1000	33000	2000	12000
							-25		500		820	10000		
RK				•		•	-40	+105	10	100	1000	10mF	2000	4000
RM			•			•	-40	+105	160	450	180	68000	2000	6000
							-25		500		330	10000		
RH		•	•			•	-40	+105	160	450	220	47000	2000	8000
RL			•		•	•	-40	+105	160	450	220	22000	5000	10000

### GROUP CHART - SCREW TERMINAL ALUMINUM ELECTROLYTIC CAPACITORS

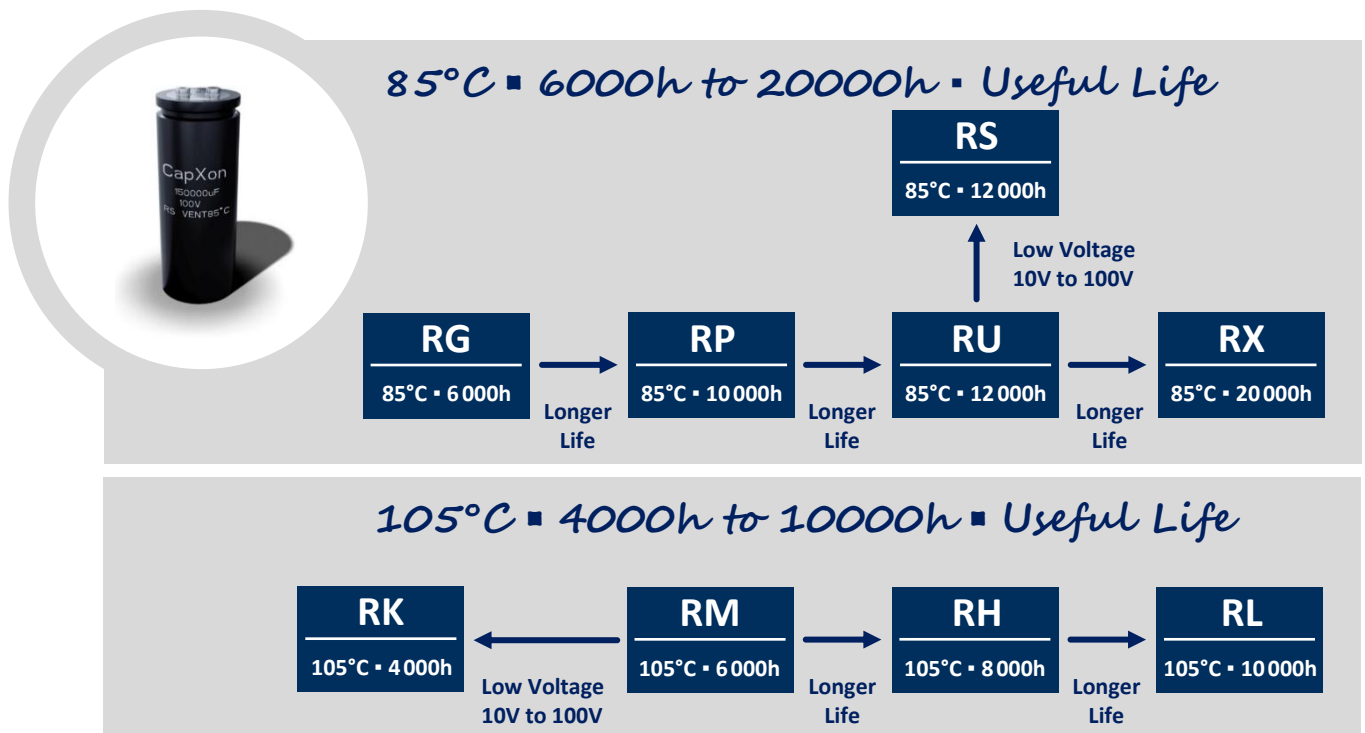

TYPICAL APPLICATIONS

Buffering	Filtering	DC Linking	Smoothing	Switched Mode Power Supplies

ADDITIONAL INFORMATION

For further information on our Aluminum Screw Terminal Capacitors, simply click on the symbols in the table below.

General Precautions & Guidelines	Packaging Information	3D Models	Reliability Tests	Environmental Declarations

Conductive Polymer Capacitors

# Stacked Types

---



OVERVIEW - SMD MULTILAYER POLYMER CAPACITORS (MLPC)



Features



Series	Datasheet	Low ESR	Low Height	Standard	Ultra Low Height	Temperature Range (°C)		Voltage Range (V)		Capacitance Range (µF)		Endurance (hours)
						-55	+105	2	25	10	470	
XA		•	•	•		-55	+105	2	25	10	470	2000
XH <b>NEW</b>		•			•	-55	+105	2	25	22	330	2000

GROUP CHART - SMD MULTILAYER POLYMER CAPACITORS (MLPC)

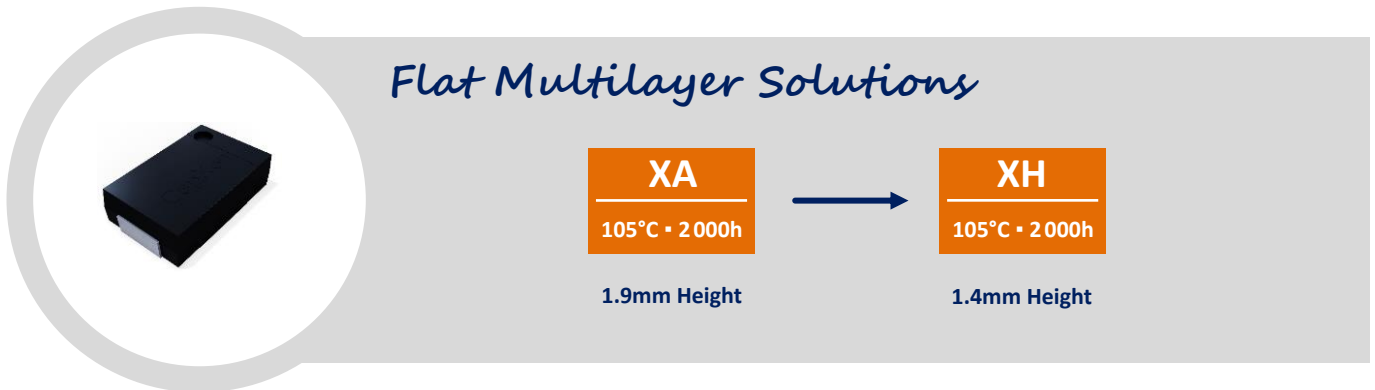

LIFETIME - SMD MULTILAYER POLYMER CAPACITORS (MLPC)

MULTILAYER POLYMER CAPACITORS **don't have a dry-out effect**, either by the ambient temperature or the temperature rise in the capacitor. Only the influence of material due to the temperature in the component and the conversion of the conductivity limit the lifetime. The Arrhenius rule also applies to MULTILAYER POLYMER CAPACITORS their application.

The lifetime increases **TEN-TIMES** when the application of the capacitor is **reduced by 20°C**.

Below an example of a 105°C series (XA) with 2000h endurance.

Lifetime	Legend	
	L <sub>0</sub>	Endurance at max. capacitor temperature
	L <sub>A</sub>	Expected lifetime at application conditions
	T <sub>0_Max</sub>	Upper category temperature
	T <sub>A</sub>	Application temperature

**Multilayer Polymer**

$$L_A = L_0 \cdot 10^{\frac{T_{0\_Max} - T_A}{20^\circ C}}$$

➔ **20°C reduced  
10 x lifetime**

**Lifetime Estimation**

**2000h@105°C**

95°C	6325 h
85°C	20000 h
75°C	63246 h
65°C	200000 h



### BENEFITS OF MLPC VS. MLCC TECHNOLOGY - EXAMPLE



Capacitor Technology	MLCC	MLPC	Benefits	
Nominal Capacitance	47µF	150µF		Gain of Integration Density
Rated Voltage	6.3V (DC)	6.3V (DC)		
Size	0805	2917		
DC Bias at 6V	80.85% drop >> 9µF	No drop = stable 150µF		No MLCC DC Bias Issue
System Capacitance at 6V	16 x 9µF = 144µF	1 x 150µF = 150µF		
Footprint per Component	0805 2mm x 1.5mm = 3mm <sup>2</sup>	2917 7.4mm x 4.3mm = 32mm <sup>2</sup>		No MLCC Cracking Issue
Footprint Occupation	A = 16 x 3mm <sup>2</sup> A = 48mm <sup>2</sup>	A = 1 x 32mm <sup>2</sup> A = 32mm <sup>2</sup>		
Size Change Ratio	100%	66%		Space Savings
Example Picture of Applied Capacitor				

### TYPICAL APPLICATIONS

CPU, FPGA and IC Buffering	High Frequency Applications	Substitution of MLCC Banks	USB Power Supplies & Banks	Voltage Stabilizing in LED Panels

### ADDITIONAL INFORMATION

For further information on our MLPC's, simply click on the symbols in the table below.

General Precautions & Guidelines	Packaging Information	3D Models	Reliability Tests	Environmental Declarations

Conductive Polymer Capacitors

# SMD Types

---



### OVERVIEW - SMD CONDUCTIVE POLYMER CAPACITORS



#### Features



Series	Datasheet	High Temperature	High Voltage	Low ESR	Low Height	Standard	Ultra Long Life	Temperature Range (°C)		Voltage Range (V)		Capacitance Range (µF)		Endurance (hours)
								-55	+105	2.5	100	10	3300	
PD			•	•		•	•	-55	+105	2.5	100	10	3300	2000
PM			•	•	•			-55	+105	2.5	100	4.7	560	2000
PV			•	•	•			-55	+105	2.5	100	6.8	2500	2000
PR				•				-55	+105	6.3	50	10	1500	5000
PG		•		•				-55	+125	6.3	50	10	1500	2000

### GROUP CHART - SMD CONDUCTIVE POLYMER CAPACITORS

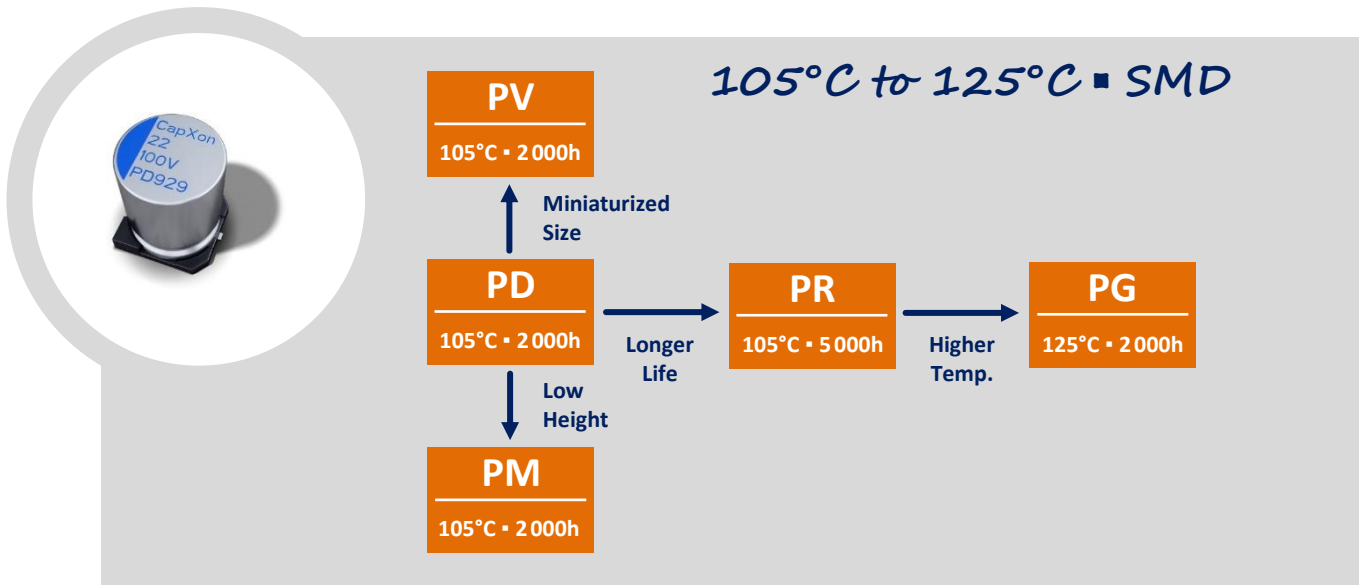

### ADDITIONAL INFORMATION

For further information on our SMD Conductive Polymer Capacitors, simply click on the symbols in the table below.

General Precautions & Guidelines	Packaging Information	3D Models	Reliability Tests	Environmental Declarations

### LIFETIME ▪ SMD CONDUCTIVE POLYMER CAPACITORS

SMD CONDUCTIVE POLYMER CAPACITORS **don't have a dry-out effect**, either by the ambient temperature or the temperature rise in the capacitor. Only the influence of material due to the temperature in the component and the conversion of the conductivity limit the lifetime. The Arrhenius rule also applies to CONDUCTIVE POLYMER CAPACITORS their application.

The lifetime increases **TEN-TIMES** when the application of the capacitor is **reduced by 20°C**.

Below an example of a 105°C series (PD) with 2000h endurance.

Lifetime	Legend	
	L <sub>0</sub>	Endurance at max. capacitor temperature
	L <sub>A</sub>	Expected lifetime at application conditions
	T <sub>0_Max</sub>	Upper category temperature
	T <sub>A</sub>	Application temperature

**Multilayer Polymer**

$$L_A = L_0 \cdot 10^{\frac{T_{0\_Max} - T_A}{20^\circ C}}$$

➔

**20°C reduced  
10 x lifetime**

**Lifetime Estimation**

**2000h@105°C**

95°C	6325 h
85°C	20000 h
75°C	63246 h
65°C	200000 h

### TYPICAL APPLICATIONS

Input/Output Filter in DC/DC Converters	High Frequency Applications	Equipment with High Expected Life	Server & Industrial PC	Voltage Stabilizing in LED Panels

Conductive Polymer Capacitors

# Radial Types

---



### OVERVIEW • THT CONDUCTIVE POLYMER CAPACITORS

#### Features

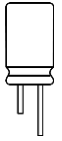

Series	Datasheet	High Temperature	High Voltage	Low ESR	Low Height	Standard	Ultra Low ESR	Ultra Long Life	Ultra Miniaturized	Temperature Range (°C)		Voltage Range (V)		Capacitance Range (µF)		Endurance (hours)
										-55	+105	2.5	25	39	3500	
PS	<a href="#">PDF</a>			•		•				-55	+105	2.5	25	39	3500	2000
PL	<a href="#">PDF</a>			•						-55	+105	2.5	16	180	3500	2000
PU	<a href="#">PDF</a>						•			-55	+105	2.5	10	180	3900	2000
PX	<a href="#">PDF</a>			•	•					-55	+105	2.5	25	6.8	820	2000
PW	<a href="#">PDF</a>			•	•					-55	+105	2.5	25	39	2500	2000
PE	<a href="#">PDF</a>			•					•	-55	+105	2.5	16	270	1200	2000
PH	<a href="#">PDF</a>		•	•						-55	+105	35	100	6.8	330	2000
PF	<a href="#">PDF</a>			•				•		-55	+105	2.5	35	10	2700	5000
PT	<a href="#">PDF</a>	•		•						-55	+125	2.5	50	22	2700	2000

### GROUP CHART • THT CONDUCTIVE POLYMER CAPACITORS

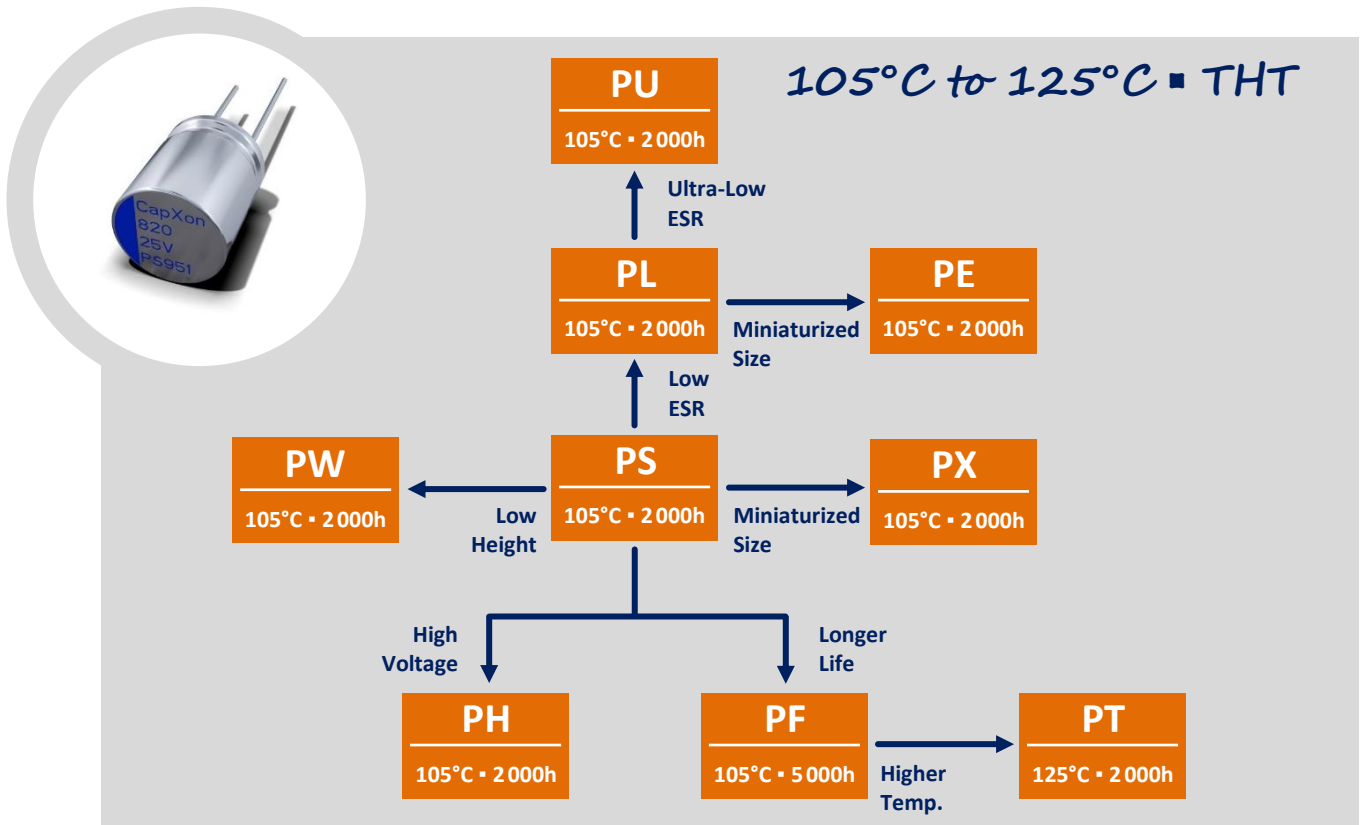

### LIFETIME ▪ SMD CONDUCTIVE POLYMER CAPACITORS

THT CONDUCTIVE POLYMER CAPACITORS **don't have a dry-out effect**, either by the ambient temperature or the temperature rise in the capacitor. Only the influence of material due to the temperature in the component and the conversion of the conductivity limit the lifetime. The Arrhenius rule also applies to CONDUCTIVE POLYMER CAPACITORS their application.

The lifetime increases **TEN-TIMES** when the application of the capacitor is **reduced by 20°C**.

Below an example of a 105°C series (PS) with 2000h endurance.

Lifetime	Legend	
	L <sub>0</sub>	Endurance at max. capacitor temperature
	L <sub>A</sub>	Expected lifetime at application conditions
	T <sub>0_Max</sub>	Upper category temperature
	T <sub>A</sub>	Application temperature

**Conductive Polymer**

$$L_A = L_0 \cdot 10^{\frac{T_{0\_Max} - T_A}{20^\circ C}}$$

➔ 20°C reduced  
10 x lifetime

**Lifetime Estimation**

2000h@105°C

95°C	6325 h
85°C	20000 h
75°C	63246 h
65°C	200000 h

### ADDITIONAL INFORMATION

For further information on our THT Conductive Polymer Capacitors, simply click on the symbols in the table below.

General Precautions & Guidelines	Packaging Information	3D Models	Reliability Tests	Environmental Declarations

### TYPICAL APPLICATIONS

Input/Output Filter in DC/DC Converters	High Frequency Applications	Equipment with High Expected Life	Server & Industrial PC	Voltage Stabilizing in LED Panels

Hybrid Electrolytic Capacitors

# SMD Types

---





OVERVIEW - SMD HYBRID CONDUCTIVE POLYMER CAPACITORS



Features

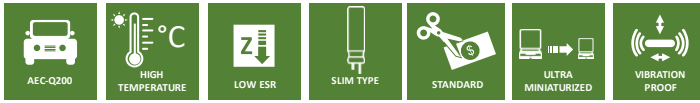

Series	Datasheet	AEC-Q200	High Temperature	Low ESR	Slim Type	Standard	Ultra Miniaturized	Ultra Low ESR	Vibration Proof	Temperature Range (°C)		Voltage Range (V)		Capacitance Range (µF)		Endurance (hours)
										-55	+105	16	200	10	1500	
AA		•		•	•	•			•	-55	+105	16	200	10	1500	5000 to 10000
AC		•	•	•	•				•	-55	+125	16	100	10	1500	4000
AB		•	•	•			•	•	•	-55	+125	25	35	33	680	4000
AN		•	•	•					•	-55	+135	16	100	10	820	4000
AU <b>NEW</b>		•	•					•	•	-55	+135	25	100	22	680	4000
AR		•	•	•					•	-55	+145	16	80	22	560	2000
AP		•	•	•					•	-55	+150	16	80	22	560	1000

SMD ECONOMY SERIES FOR NON-AUTOMOTIVE APPLICATIONS

Series	Datasheet	AEC-Q200	High Temperature	Low ESR	Slim Type	Standard	Ultra Miniaturized	Ultra Low ESR	Vibration Proof	Temperature Range (°C)		Voltage Range (V)		Capacitance Range (µF)		Endurance (hours)
										-55	+105	16	100	10	1500	
YA <b>NEW</b>				•		•				-55	+105	16	100	10	1500	10000
YC <b>NEW</b>			•	•		•				-55	+125	16	100	10	1500	4000
YB <b>NEW</b>			•	•		•	•	•		-55	+125	25	35	33	680	4000

ADDITIONAL INFORMATION

For further information on our SMD Hybrid Polymer Capacitors, simply click on the symbols in the table below.

General Precautions & Guidelines	Packaging Information	3D Models	Reliability Tests	Environmental Declarations

### GROUP CHART • HIGH PERFORMANCE SERIES FOR AUTOMOTIVE APPLICATIONS

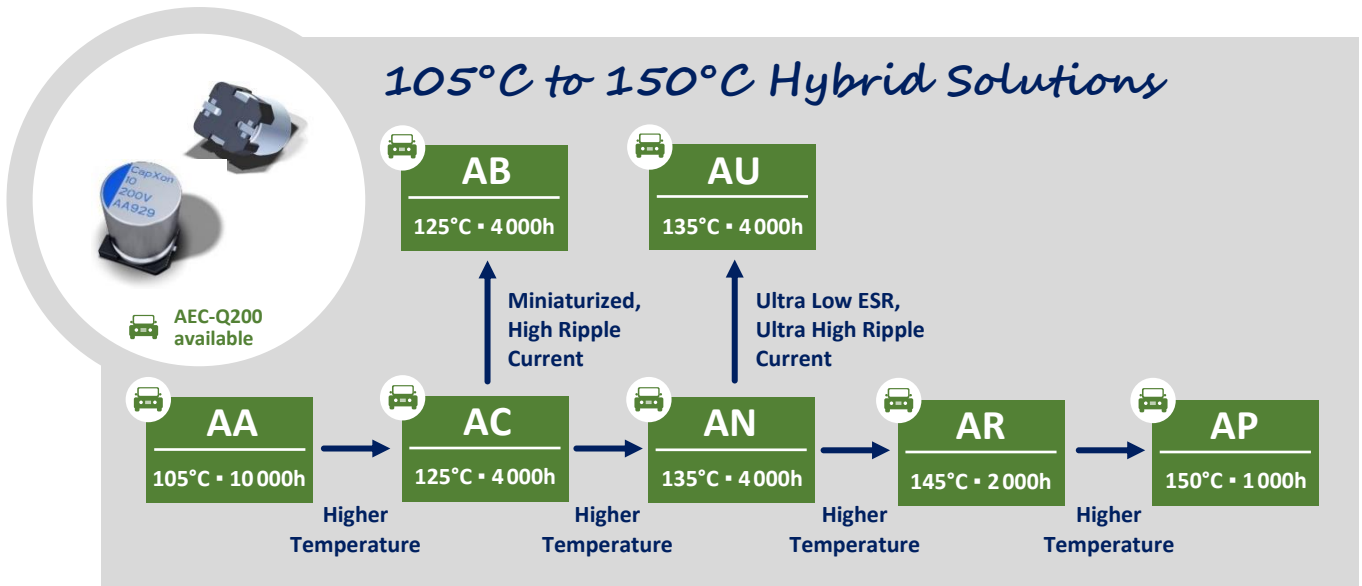

### GROUP CHART • ECONOMY SERIES FOR NON-AUTOMOTIVE APPLICATIONS

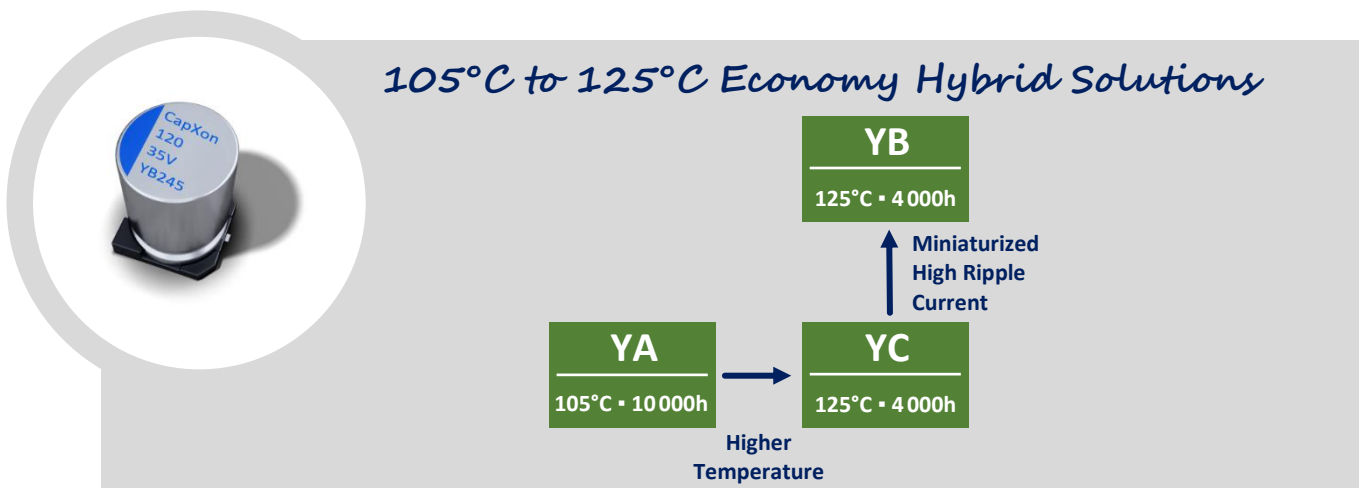

### TYPICAL APPLICATIONS

Automotive Electronics *	DC Link in Motor Drives	Harsh Environmental Applications	Input/Output Filter in DC/DC Converters	Power and Battery Decoupling

\* Automotive electronics not for YA, YB and YC series.

### BENEFITS OF HYBRID POLYMER CAPACITORS

As a mix of the two worlds, the HYBRID POLYMER TECHNOLOGY offers the best performance of high-capacity storage components.



### HYBRID POLYMER PERFORMANCE

The bandwidth and performance speak for themselves. Exceed existing limits and raise the bar.

That is performance "made by CapXon"

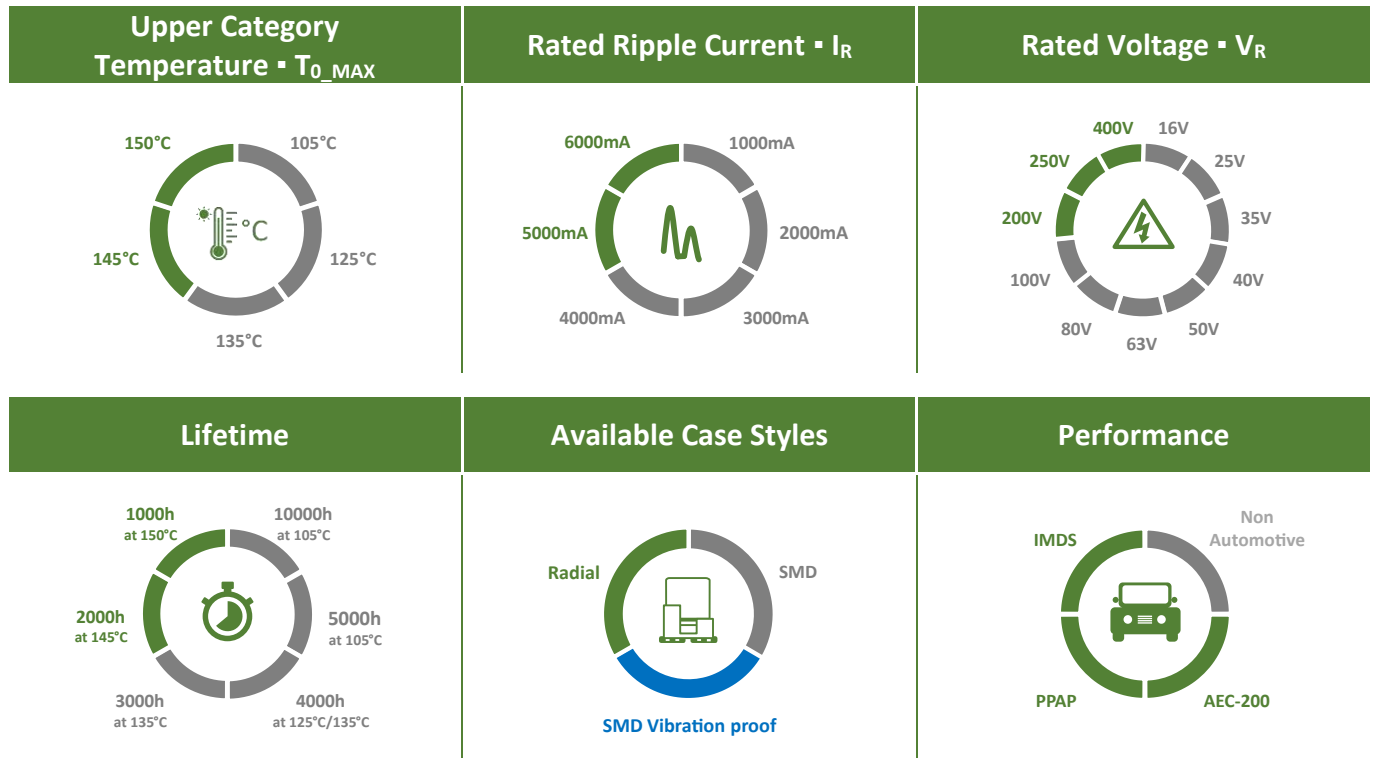

Hybrid Electrolytic Capacitors

# Radial Types

---



OVERVIEW - THT HYBRID POLYMER CONDUCTIVE CAPACITORS

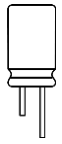

Features



Series	Datasheet	AEC-Q200	High Temperature	High Voltage	Low ESR	Slim Type	Standard	Ultra Low ESR	Temperature Range (°C)		Voltage Range (V)		Capacitance Range (µF)		Endurance (hours)
									-55	+105	16	400	1.2	1500	
AS		•	•	•	•	•	•	•	-55	+105	16	400	1.2	1500	2000 to 10000
AT		•	•	•	•	•	•	•	-55	+125	16	100	8.2	1500	2000 to 4000
AK		•	•	•	•	•	•	•	-55	+135	16	100	8.2	560	2000 to 3000
AE <b>NEW</b>		•	•	•	•	•	•	•	-55	+135	25	100	22	680	4000
AL		•	•	•	•	•	•	•	-55	+145	16	80	8.2	560	2000
AM		•	•	•	•	•	•	•	-55	+150	16	80	8.2	560	1000

THT ECONOMY SERIES FOR NON-AUTOMOTIVE APPLICATIONS

Series	Datasheet	AEC-Q200	High Temperature	High Voltage	Low ESR	Slim Type	Standard	Ultra Low ESR	Temperature Range (°C)		Voltage Range (V)		Capacitance Range (µF)		Endurance (hours)
									-55	+105	16	100	10	1500	
YS <b>NEW</b>		•	•	•	•	•	•	•	-55	+105	16	100	10	1500	5000 to 10000
YT <b>NEW</b>		•	•	•	•	•	•	•	-55	+125	16	100	10	1500	2000 to 4000

ADDITIONAL INFORMATION

For further information on our THT Hybrid Polymer Capacitors, simply click on the symbols in the table below.

General Precautions & Guidelines	Packaging Information	3D Models	Reliability Tests	Environmental Declarations

### GROUP CHART • HIGH PERFORMANCE SERIES FOR AUTOMOTIVE APPLICATIONS

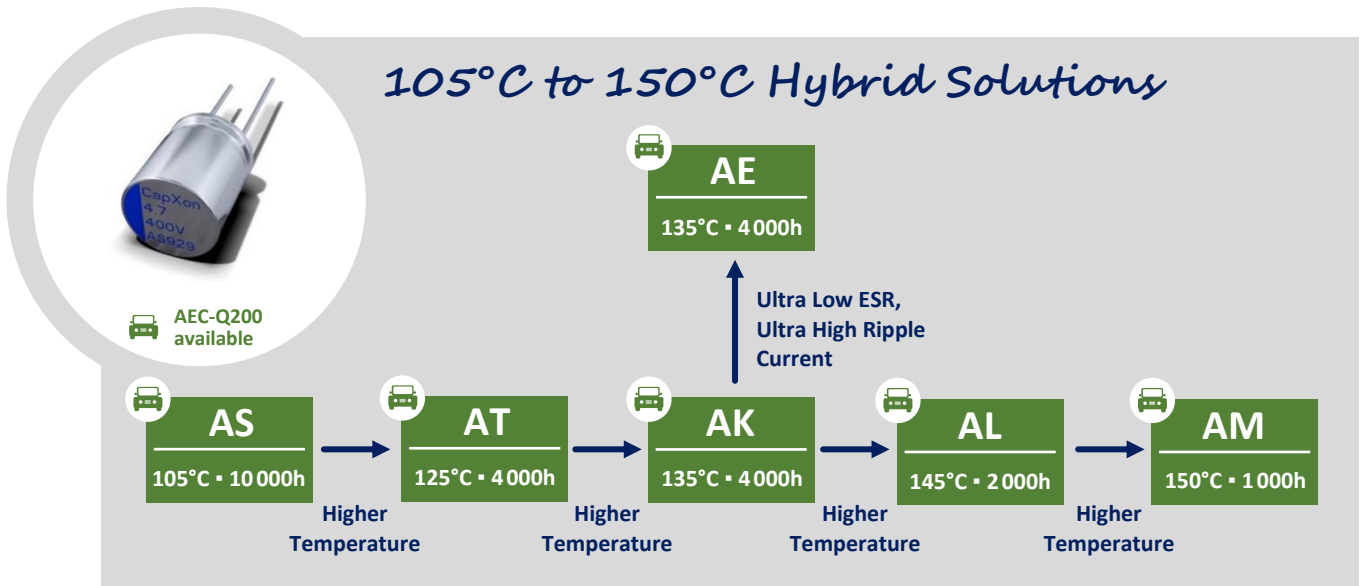

### GROUP CHART • ECONOMY SERIES FOR NON-AUTOMOTIVE APPLICATIONS

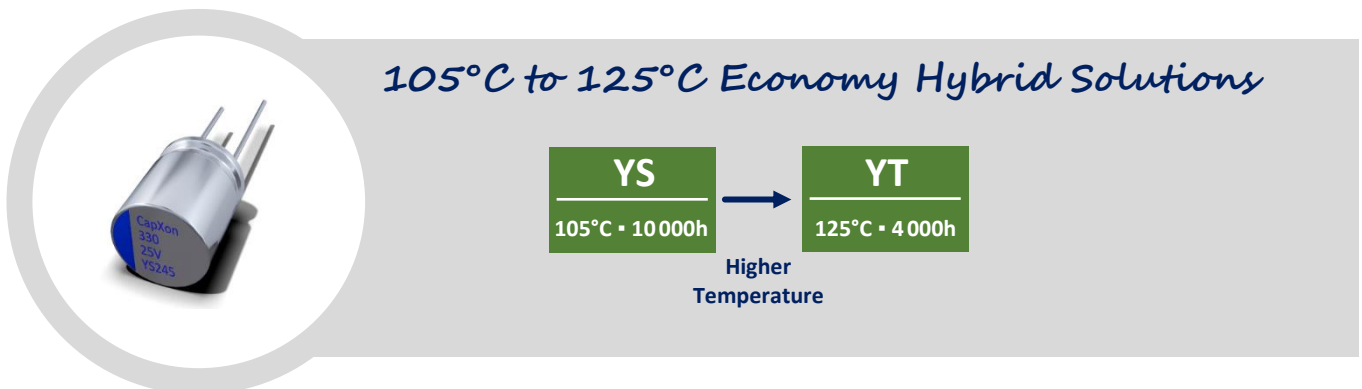

### TYPICAL APPLICATIONS

Automotive Electronics	DC Link in Motor Drives	Harsh Environmental Applications	Input/Output Filter in DC/DC Converters	Power and Battery Decoupling

\* Automotive electronics not for YS and YT series.

### BENEFITS OF HYBRID POLYMER CAPACITORS

As a mix of the two worlds, the HYBRID POLYMER TECHNOLOGY offers the best performance of high-capacity storage components.



### HYBRID POLYMER PERFORMANCE

The bandwidth and performance speak for themselves. Exceed existing limits and raise the bar.

That is performance "made by CapXon"

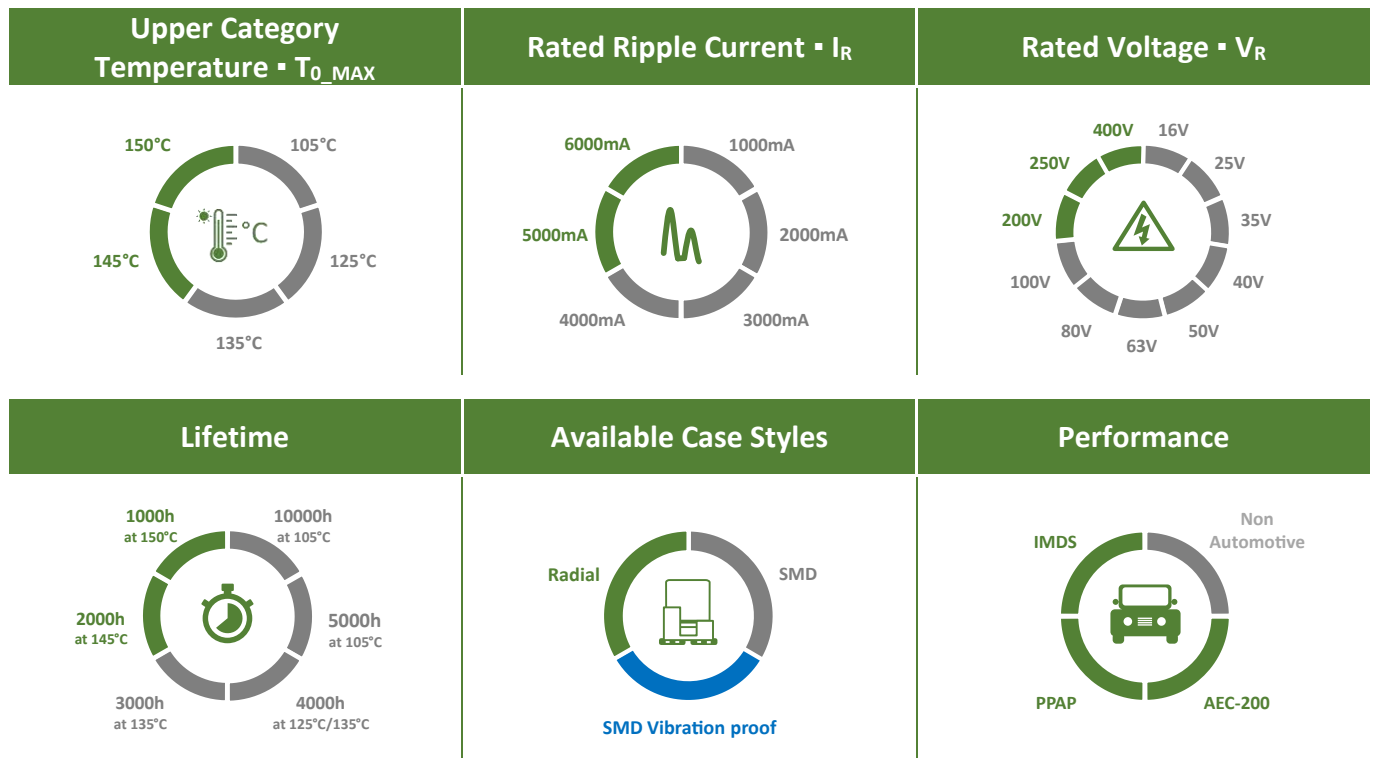

# CAPXON

IATF 16949

AEC-Q200

ISO 9001

ISO 14001

QC 080000



[www.capxongroup.com](http://www.capxongroup.com)

## Taiwan

**CapXon Technology Limited Taiwan Branch**  
5F, No. 157, Datong Road, Sec. 2, XiZhi Dist.,  
New Taipei City, 22183, Taiwan R. O. C.  
+886-2-8692-6611  
[sales@capxon-taiwan.com](mailto:sales@capxon-taiwan.com)

## China

**CapXon Electronic Technology Co., Ltd.**  
Fengbin Industrial Park A102, Tangwei Community,  
Fenghuang street, Guangming District, (No. 4132 Songbai Rd.)  
Shenzhen 518106, China  
+86-755-2717-7888  
[sales@capxon.com.cn](mailto:sales@capxon.com.cn)

## South Korea

**CapXon Korea Office**  
RM309, Metrokhan, 239 Pyeongchon-daero, Dongan-gu,  
Anyang-si, Gyeonggi-do, Korea, 14047  
[sales@capxon-korea.com](mailto:sales@capxon-korea.com)

## Southeast Asia/India

**CapXon Singapore Office**  
51 Goldhill Plaza #07-10/11  
Singapore 308900  
+65-3-1572870  
[sales@capxon-asia.com](mailto:sales@capxon-asia.com)  
[sales@capxon-india.com](mailto:sales@capxon-india.com)

## United States of America

**CapXon US Office**  
New York +1-607-846 4546  
[sales@capxon-usa.com](mailto:sales@capxon-usa.com)

## Europe

**CapXon Europe Office**  
Schwalbenweg 11  
72793 Pfullingen, Germany  
+49-7121-1452700  
[sales@capxon-europe.com](mailto:sales@capxon-europe.com)

The content of this catalog is created with utmost care.  
However, CapXon does not guarantee the accuracy,  
completeness and timeliness of the content  
provided. Specifications subject to  
change without notice.

