



ISO9001-2008
Certificate No:02411Q20838R2M

CAREFUL環境關聯物質管控標準: Cd<5ppm; Pb<50ppm; Hg:ND; Cr6+:ND

Defer to: **SONY/SS-00259** ; SAMSUNG/OQA-2049 ; **MICROSOFT/H00594** ; FOXCONN/EPI12 ; **HP/HX-00011-00...**

承認書

SPECIFICATION FOR APPROVAL

客戶名稱 CUSTOMER	LEPCOS
品名規格 DESCRIPTION	F2 RH 8×10×5.6
客戶料號 CUS. P/N	
提出日期 DATE	May.29. 2024.
編號 SERIAL NO.	KF 24052935848

出圖 DRAWING			承認 CUSTOMER APPROVE	
發行 MADE	復核 CHECKED	確認 APPROVED		
DATE: 2024年05月29日				

說明Note:
本承認書在客戶收到7天之內，須簽章返回，逾期視為默認。
The Specification Approval is required to be sent back to the supplier with customer's chop or signature on it within 4 days after receiving it, or we will take it as approved by customer automatically.



科峰集團

CAREFUL GROUP

www.careful.cn
e sales@careful.cn
e info@careful.cn

湖州科峰磁業有限公司
HuZhou Careful Magnetism Co.,Ltd.

浙江省湖州市含山工業區 313014
Hanshan Industry Zone Huzhou Zhejiang

TEL: 00 86 - 572 - 367 0006 / 367 2766 FAX: 00 86 - 572 - 367 0025
TEL: 00 86 - 572 - 367 0006 / 367 2766 FAX: 00 86 - 572 - 367 0025

嘉興科峰磁電股份有限公司
JiaXing Careful Magnetism & Electron Co.,Ltd.

浙江省嘉興市河山工業區 314512
Heshan Industry Zone Jiaxing Zhejiang

TEL: 00 86 - 573 - 8867 1616 / 8867 0988 FAX: 00 86 - 573 - 8867 1515
TEL: 00 86 - 573 - 8867 1616 / 8867 0988 FAX: 00 86 - 573 - 8867 1515

承認書

SPECIFICATION FOR APPROVAL

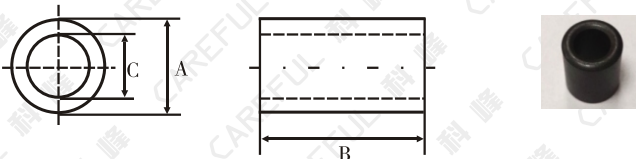
客戶名稱 CUSTOMER	LEPCOS	日期 DATE	2024.05.29.
規格 ITEM	F2 RH 8×10×5.6	編號 SERIAL NO.	KF 24052935848
1.1. 形狀尺寸(單位/毫米): SHAPE & DIMENSION(unit/mm):	1.2. 實物圖: The Sample::	A	8 ± 0.4 mm
		B	10 ± 0.4 mm
		C	5.6 ± 0.3 mm
		D	
		E	
		F	
		G	
		H	

2. 電氣性能檢測項目: ELECTRICAL REQUIREMENTS:

<input type="checkbox"/> L		TEST FREQ	KHZ MHZ
<input type="checkbox"/> Q		TEST FREQ	KHZ MHZ
<input checked="" type="checkbox"/> Z	Z1= 20Ω MIN	25 KHZ	Z2= 50Ω MIN
	Z3= /	KHZ	Z4= /
溫度 TEMP	℃	濕度 HUMIDITY	%
線組 WINDING	Φ0.5x0.5TSx100L(mm)		

測試儀器 TEST INSTRUMENTS

- Q-METER:
○HP 4342A ○MQ-172
- L.C.R. METER:
○HP 4284A
- IMPEDANCE ANALYZER:
○HP 4396B ○HP 4191A ∅E4991A
∅Agilent 16194A-TESTFIXTURE
- L-METER:
○TH 2817A
- DIGITAL MINI-OHMMETER:
○VP2941A

3. 外觀標準: 依下表對照檢索: THE LIMIT OF BREAKAGE: CHECKED BELOW:

OD (mm)	0~5	5.1~10	10.1~15	15.1~20	20.1~25	25.1~30	30.1~35	35以上
缺陷面积 Defect area (mm ²)	≦1	≦2	≦3	≦4	≦5	≦6	≦7	≦8
缺陷个数 Number of defects (≦)	1	2	3	3	3	3	2	2



4. 材質特性 MATERIAL CHARACTERISTICS

材料牌號 Material	初始磁導率 Initial Permeability	比損耗因子 Relative Loss Factor	比溫度系數 Relative Temperature Coefficient	飽和磁通密度 Saturation Magnetic Flux Density	剩磁 Remanence	矯頑力 Coercivity	居裏溫度 Curie Temperature	電阻率 Electrical Resistivity	密度 Density
Unit symbol	μ_1	$\tan \delta / \mu_1$	$\alpha \mu_1 \gamma$	Bs (MT)	Br (MT)	HC (A/m)	Tc (°C)	ρ (Ω · m)	d g/cm ³
F2	650 ±20%	20 (0.1MHz) ×10 ⁻⁶	2-5 ×10 ⁻⁶	260(1600A/m)	150	35	>140	>10 ⁵	4.6

A	首版First Edition	2024-05-29	Rosie
版本Rev.	變更內容說明Description of Change	日期Date	姓名Name

檢驗數據

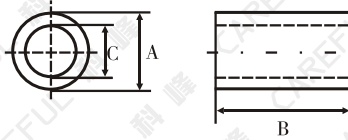
INSPECTION DATA

客戶名稱 CUSTOMER	LEPCOS		日期 DATE	2024.05.29.	數量 QUANTITY	10PCS
編號 SERIAL NO.	KF 24052935848		形狀尺寸(單位/毫米): SHAPE & DIMENSION(unit/mm):		實物圖: The Sample::	
規格 ITEM	F2 RH 8x10x5.6					
線組 WINDING	Φ0.5x0.5TSx100L(mm)					
測試頻率 TEST FREQ	Z1= 25 KHZ 25 MHZ	Z2= 100 KHZ 100 MHZ				
	Z3= / KHZ / MHZ	Z4= / KHZ / MHZ				
溫度 TEMP	℃	濕度 HUMIDITY	%			

項目 TEST ITEM	電氣性能 ELECTRIC CHARACTERISTICS						尺寸(單位:毫米) DIMENSION(unit:mm)					
	Q	L(μH) (MH)	Z1(Ω)	Z2(Ω)	Z3(Ω)	Z4(Ω)	A	B	C	D	E	F
			20	50			8	10	5.6			
+			/	/			0.4	0.4	0.3			
-			0	0			0.4	0.4	0.3			
1			29.2	75.6			8.18	10.06	5.62			
2			28.6	77.2			8.17	10.19	5.60			
3			29.3	76.8			8.15	10.08	5.57			
4			28.8	77.4			8.09	10.09	5.59			
5			29.0	75.2			8.07	10.07	5.64			
6			28.6	77.0			8.12	10.18	5.65			
7			29.6	76.2			8.18	10.15	5.58			
8			29.4	75.6			8.11	10.12	5.54			
9			28.7	77.3			8.13	10.14	5.66			
10			29.1	75.4			8.16	10.17	5.52			
\bar{X}			29.03	76.37			8.13	10.12	5.59			
Y/N			Y	Y			Y	Y	Y			

測試儀器:
TEST INSTRUMENTS:

E4991A+16194A

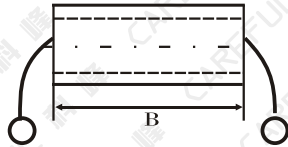

檢驗
INSPECTED

汪建琴

復核
CHECKED

周紀君

確認
APPROVED

沈學泉

A	首版First Edition	2024-05-29	Rosie
版本Rev.	變更內容說明Description of Change	日期Date	姓名Name

阻抗 - 頻率曲線

IMPEDANCE V.S FREQUENCY (Z-Y)

客戶名稱 CUSTOMER	LEPCOS	日期 DATE	2024.05.29.
規格 ITEM	F2 RH 8x10x5.6	編號 SERIAL NO.	KF 24052935848

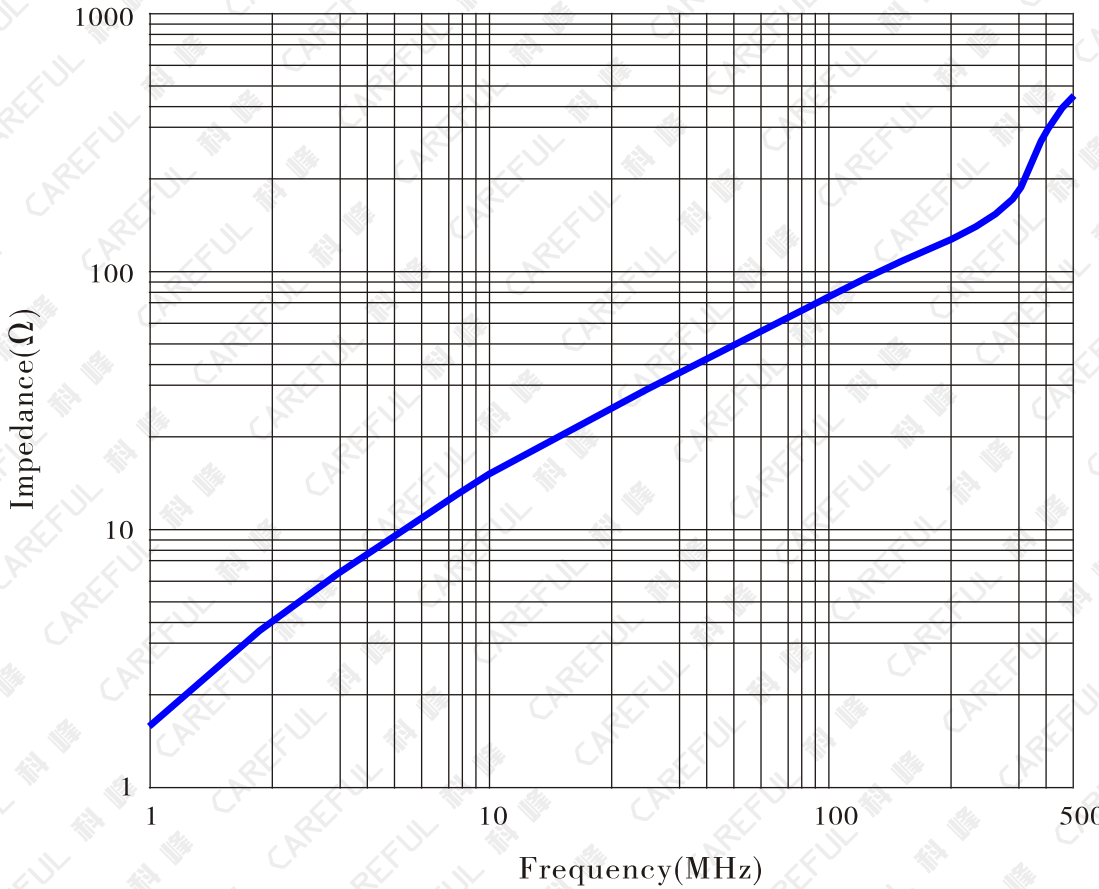

測試條件:
TESTING CONDITION:

- 測試儀器: E4991A+16194A
Testing Equipment:
- 測試頻率區間: 1-500MHz
Testing Frequency Range:
- 測試線組: Φ0.5x0.5TSx100L(mm)
Testing Coil Specification:

說明Note:
本承認書在客戶收到7天之內, 須簽章返回, 逾期視為默認。
The Specification Approval is required to be sent back to the supplier with customer's chop or signature on it within 4 days after receiving it, or we will take it as approved by customer automatically.

測試 TESTED	復核 CHECKED	確認 APPROVED
汪建琴	周紀君	沈學泉

A	首版First Edition	2024-05-29	Rosie
版本Rev.	變更內容說明Description of Change	日期Date	姓名Name