



CAREFUL環境關聯物質管控標準: Cd<5ppm; Pb<50ppm; Hg:ND; Cr6+:ND

ISO9001-2008
Certificate No:02411Q20838R2M

Defer to: **SONY/SS-00259** ; SAMSUNG/OQA-2049 ; **MICROSOFT/H00594** ; FOXCONN/EPI12 ; **HP/HX-00011-00...**

承 認 書

SPECIFICATION FOR APPROVAL

客戶名稱 CUSTOMER	LEPCOS
品名規格 DESCRIPTION	F2-CP RH 17.5×28.5×10.7
客戶料號 CUS. P/N	
提出日期 DATE	Apr.09. 2019.
編 號 SERIAL NO.	KF 19040927605

出 圖 DRAWING			承 認 CUSTOMER APPROVE	
發行 MADE	復 核 CHECKED	確 認 APPROVED		
DATE: 2019年04月09日				



科峰集團

CAREFUL GROUP

www.careful.cn
e sales@careful.cn
e info@careful.cn

湖州科峰磁業有限公司
HuZhou Careful Magnetism Co.,Ltd.

浙江省湖州市含山工業區 313014
Hanshan Industry Zone Huzhou Zhejiang

TEL: 00 86 - 572 - 367 0006 / 367 2766
TEL: 00 86 - 572 - 367 0006 / 367 2766

FAX: 00 86 - 572 - 367 0025
FAX: 00 86 - 572 - 367 0025

嘉興科峰磁電有限公司
JiaXing Careful Magnetism & Electron Co.,Ltd.

浙江省嘉興市河山工業區 314512
Heshan Industry Zone Jiaxing Zhejiang

TEL: 00 86 - 573 - 8867 1616 / 8867 0988
TEL: 00 86 - 573 - 8867 1616 / 8867 0988

FAX: 00 86 - 573 - 8867 1515
FAX: 00 86 - 573 - 8867 1515

承 認 書



SPECIFICATION FOR APPROVAL

客戶名稱 CUSTOMER	LEPCOS	日期 DATE	2019040927605										
規格 ITEM	F2-CP RH 17.5×28.5×10.7	編號 SERIAL NO.	KF 19040927605										
1.1. 形狀尺寸(單位/毫米): SHAPE & DIMENSION(unit/mm): 		1.2. 實物圖: The Sample:: 											
		A	17.5 ± 0.4 mm										
		B	28.5 ± 0.6 mm										
		C	10.7 ± 0.4 mm										
		D											
		E											
		F											
		G											
		H											
2. 電氣性能檢測項目: ELECTRICAL REQUIREMENTS:		測試儀器 TEST INSTRUMENTS											
<input type="checkbox"/> L		TEST FREQ	KHZ MHZ										
<input type="checkbox"/> Q		TEST FREQ	KHZ MHZ										
<input checked="" type="checkbox"/> Z	Z1= 72Ω MIN	25 KHZ	Z2= 111Ω MIN										
	Z3= /	KHZ MHZ	Z4= /										
溫度 TEMP	℃	濕度 HUMIDITY	%										
綫組 WINDING	Φ0.65x0.5TSx100L(mm)												
3. 外觀: THE LIMIT OF BREAKAGE:													
<table border="1" style="width: 100%; border-collapse: collapse;"> <thead> <tr> <th style="width: 60%;">項目 Item</th> <th>標準值 Standard Value</th> </tr> </thead> <tbody> <tr> <td>一處缺陷的面積 Area of a breakage</td> <td>≤1mm²</td> </tr> <tr> <td>總缺陷面積 All area of the breakage</td> <td>≤2mm²</td> </tr> <tr> <td>缺陷深度 The depth of the breakage</td> <td>≤0.4mm</td> </tr> <tr> <td>毛刺長度 The length of burr</td> <td>≤0.2mm</td> </tr> </tbody> </table>		項目 Item	標準值 Standard Value	一處缺陷的面積 Area of a breakage	≤1mm ²	總缺陷面積 All area of the breakage	≤2mm ²	缺陷深度 The depth of the breakage	≤0.4mm	毛刺長度 The length of burr	≤0.2mm		
項目 Item	標準值 Standard Value												
一處缺陷的面積 Area of a breakage	≤1mm ²												
總缺陷面積 All area of the breakage	≤2mm ²												
缺陷深度 The depth of the breakage	≤0.4mm												
毛刺長度 The length of burr	≤0.2mm												
4. 包裝: PACKAGING:													
內包裝採用泡塑盒, 外包裝採用紙箱, 每箱產品外面都蓋上合格章(包括品名、數量、批號、檢驗員)。 Inner packing adopts foam plastics box, outer packing adopts carton and each carton should have a qualified chapter label outside(include the variety, quantity, batch number and inspector).													

A	首版First Edition	2019-04-09	Rosie
版本Rev.	變更內容說明Description of Change	日期Date	姓名Name

檢驗數據

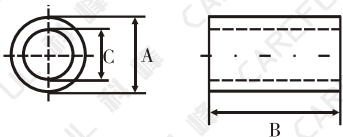
INSPECTION DATA

客戶名稱 CUSTOMER	LEPCOS		日期 DATE	2019.04.09.	數量 QUANTITY	10PCS
編號 SERIAL NO.	KF 19040927605		形狀尺寸(單位/毫米): SHAPE & DIMENSION(unit/mm):		實物圖: The Sample:::	
規格 ITEM	F2-CP RH 17.5x28.5x10.7					
線組 WINDING	Φ0.65x0.5TSx100L(mm)					
測試頻率 TEST FREQ	Z1=	25 KHZ MHZ	Z2=	100 KHZ MHZ		
	Z3=	— KHZ MHZ	Z4=	— KHZ MHZ		
溫度 TEMP	℃	濕度 HUMIDITY	%			

項目 TEST ITEM	電氣性能 ELECTRIC CHARACTERISTICS						尺寸(單位:毫米) DIMENSION(unit:mm)					
	Q	L(μH) (MH)	Z1(Ω)	Z2(Ω)	Z3(Ω)	Z4(Ω)	A	B	C	D	E	F
			72	111			17.5	28.5	10.7			
+			/	/			0.4	0.6	0.4			
-			0	0			0.4	0.6	0.4			
1			79.6	154.2			17.25	28.50	10.54			
2			79.8	154.0			17.18	28.54	10.52			
3			80.2	153.6			17.08	28.36	10.60			
4			80.0	153.8			17.19	28.40	10.61			
5			79.5	154.4			17.26	28.34	10.53			
6			80.4	152.2			17.31	28.28	10.45			
7			80.0	153.0			17.24	28.29	10.62			
8			79.2	152.6			17.12	28.37	10.44			
9			79.4	154.3			17.25	28.45	10.46			
10			80.3	152.6			17.17	28.49	10.53			
\bar{X}			79.84	153.47			17.20	28.40	10.53			
Y/N			Y	Y			Y	Y	Y			

測試儀器:
TEST INSTRUMENTS:

E4991A+16194A

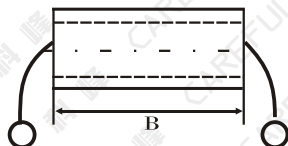

檢驗
INSPECTED

汪建琴

復核
CHECKED



確認
APPROVED



A	首版First Edition	2019-04-09	Rosie
版本Rev.	變更內容說明Description of Change	日期Date	姓名Name

阻抗 - 頻率曲綫

IMPEDANCE V.S FREQUENCY (Z-Y)

客戶名稱 CUSTOMER	LEPCOS	日期 DATE	2019.04.09.
規格 ITEM	F2-CP RH 17.5x28.5x10.7	編號 SERIAL NO.	KF 19040927605

材質特性 MATERIAL CHARACTERISTICS

材料牌號 Material	初始磁導率 Initial Permeability	比損耗因子 Relative Loss Factor	比溫度系數 Relative Temperature Coefficient	飽和磁通密度 Saturation Magnetic Flux Density	剩磁 Remanence	矯頑力 Coercivity	居裏溫度 Curie Temperature	電阻率 Electrical Resistivity	密度 Density
Unit symbol	μ_i $\pm 20\%$	$\tan \delta / \mu_i$ $\times 10^{-6}$	$\alpha \mu_i \gamma$ $\times 10^{-6}$	Bs (MT)	Br (MT)	HC (A/m)	Tc (°C)	ρ ($\Omega \cdot m$)	d g/cm ³
F2	650	20 (0.1MHz)	2 - 5	260(1600A/m)	150	35	>140	>10 ⁵	4.6

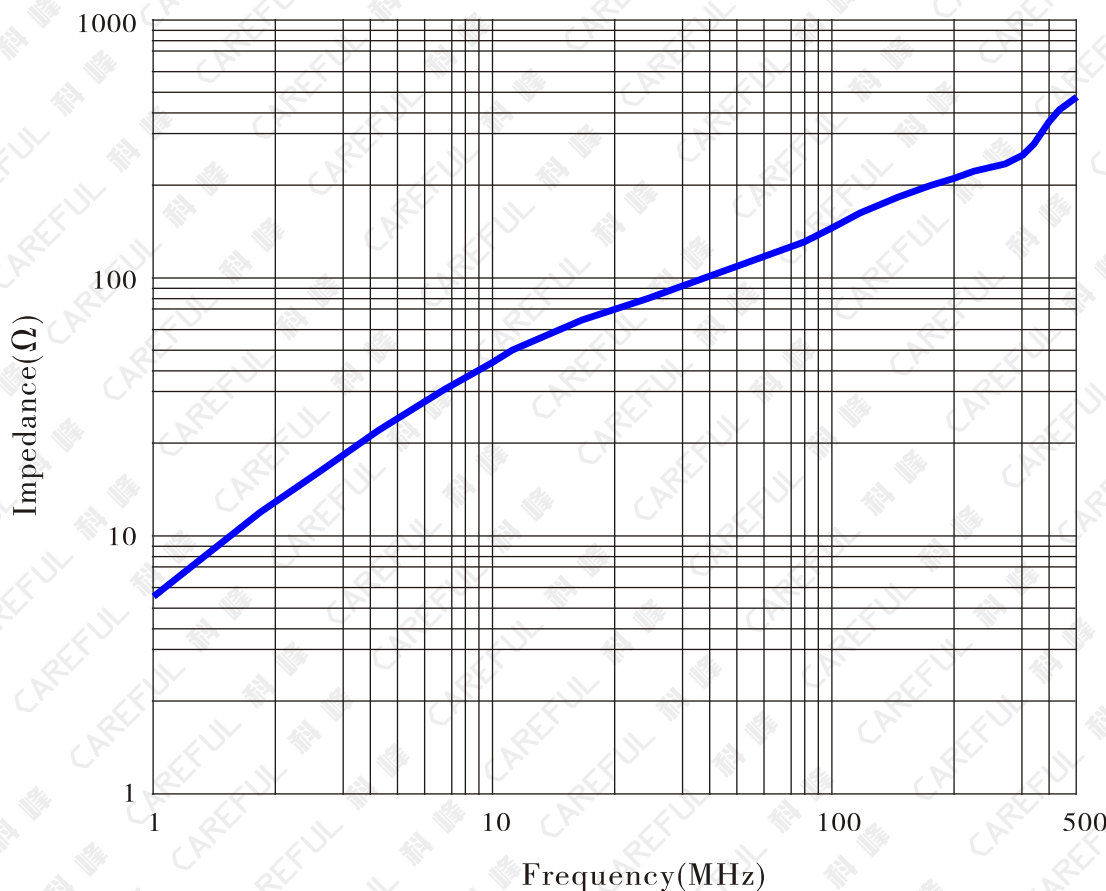

測試條件:
TESTING CONDITION:

- 測試儀器: E4991A+16194A
Testing Equipment:
- 測試頻率區間: 1-500MHz
Testing Frequency Range:
- 測試線組: $\Phi 0.65 \times 0.5 \text{TS} \times 100 \text{L}(\text{mm})$
Testing Coil Specification:

測試 TESTED	復核 CHECKED	確認 APPROVED
汪建琴	周紀君	沈學泉

A	首版First Edition	2019-04-09	Rosie
版本Rev.	變更內容說明Description of Change	日期Date	姓名Name