

5A, 600V FIELD STOP IGBT

DESCRIPTION

The SGTP5T60SD1D/F/S field stop IGBT features low conduction loss and switching loss, is applicable to UPS, SMPS, and PFC fields.

FEATURES

- ◆ 5A, 600V, $V_{CE(sat)(typ.)}=1.5V@I_C=5A$
- ◆ Low conduction loss
- ◆ Fast switching
- ◆ High input impedance

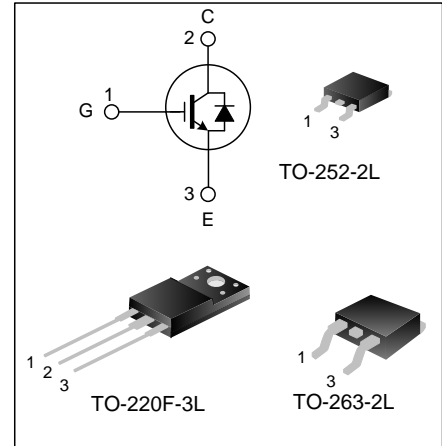

NOMENCLATURE

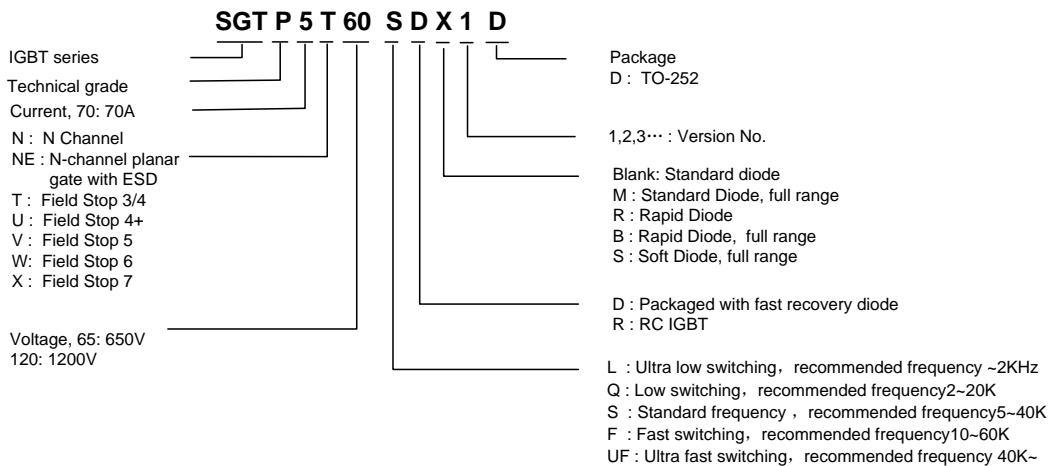

ORDERING INFORMATION

Part No.	Package	Marking	Hazardous Substance Control	Packing Type
SGTP5T60SD1DTR	TO-252-2L	P5T60SD1	Halogen free	Tape&Reel
SGTP5T60SD1F	TO-220F-3L	P5T60SD1	Pb free	Tube
SGTP5T60SD1S	TO-263-2L	P5T60SD1S	Halogen free	Tube
SGTP5T60SD1STR	TO-263-2L	P5T60SD1S	Halogen free	Tape&Reel

ABSOLUTE MAXIMUM RATINGS (T_C=25°C UNLESS OTHERWISE NOTED)

Parameter	Symbol	Ratings			Units
		SGTP5T60SD1D	SGTP5T60SD1F	SGTP5T60SD1S	
Collector to Emitter Voltage	V _{CE}	600			V
Gate to Emitter Voltage	V _{GE}	±30			V
Collector Current	I _C	T _C =25°C			A
		T _C =100°C			
Pulsed Collector Current	I _{CM}	15			A
Diode current	I _F	10			A
Short-circuit time (V _{GE} =15V, V _{CC} =300V)	T _{sc}	10			μs
Power Dissipation	P _D	82	35	83	W
Operating Junction Temperature	T _J	-55~+150			°C
Storage Temperature Range	T _{stg}	-55~+150			°C

THERMAL CHARACTERISTICS

Parameter	Symbol	Ratings			Units
		SGTP5T60SD1D	SGTP5T60SD1F	SGTP5T60SD1S	
Thermal Resistance, Junction to Case (IGBT)	R _{θJC}	1.51	3.6	1.5	°C/W
Thermal Resistance, Junction to Case (FRD)	R _{θJC}	2.14	3.7	2.6	°C/W
Thermal Resistance, Junction-to-Ambient	R _{θJA}	72	63	51	°C/W

ELECTRICAL CHARACTERISTICS OF IGBT ($T_C = 25^\circ\text{C}$, UNLESS OTHERWISE NOTED)

Parameter	Symbol	Test conditions	Min.	Typ.	Max.	Units
Collector to Emitter Breakdown Voltage	BV_{CE}	$V_{GE}=0V, I_C=250\mu A$	600	--	--	V
C-E Leakage Current	I_{CES}	$V_{CE}=600V, V_{GE}=0V$	--	--	200	μA
G-E Leakage Current	I_{GES}	$V_{GE}=20V, V_{CE}=0V$	--	--	± 400	nA
G-E Threshold Voltage	$V_{GE(th)}$	$I_C=250\mu A, V_{CE}=V_{GE}$	3.5	5.5	6.5	V
Collector to Emitter Saturation Voltage	$V_{CE(sat)}$	$I_C=5A, V_{GE}=15V$	--	1.5	2.0	V
		$I_C=5A, V_{GE}=15V, T_C=125^\circ\text{C}$	--	1.7	--	V
Input Capacitance	C_{ies}	$V_{CE}=30V, V_{GE}=0V, f=1\text{MHz}$	--	340	--	pF
Output Capacitance	C_{oes}		--	26	--	
Reverse Transfer Capacitance	C_{res}		--	7.6	--	
Turn-On Delay Time	$T_{d(on)}$	$V_{CE}=400V$ $I_C=5A$ $R_g=10\Omega$	--	7	--	ns
Rise Time	T_r		--	14	--	
Turn-Off Delay Time	$T_{d(off)}$		--	18	--	
Fall Time	T_f		--	145	--	
Turn-On Switching Loss	E_{on}	$V_{GE}=15V$	--	0.2	--	mJ
Turn-Off Switching Loss	E_{off}	Inductive Load	--	0.07	--	
Total Switching Loss	E_{st}		--	0.27	--	
Total Gate Charge	Q_g	$V_{CE}=400V, I_C=5A, V_{GE}=15V$	--	18.5	--	nC
Gate to Emitter Charge	Q_{ge}		--	5.1	--	
Gate to Collector Charge	Q_{gc}		--	8.6	--	

ELECTRICAL CHARACTERISTICS OF FRD ($T_C=25^\circ\text{C}$, UNLESS OTHERWISE NOTED)

Parameter	Symbol	Test conditions	Min.	Typ.	Max.	Units
Diode Forward Voltage	V_{FM}	$I_F=5A, T_C=25^\circ\text{C}$	--	1.3	1.8	V
		$I_F=5A, T_C=125^\circ\text{C}$	--	1.1	--	
Diode Reverse Recovery Time	T_{rr}	$I_{ES}=5A, di_{ES}/dt=200A/\mu s$	--	40	--	ns
Diode Reverse Recovery Charge	Q_{rr}	$I_{ES}=5A, di_{ES}/dt=200A/\mu s$	--	80	--	nC

TYPICAL CHARACTERISTICS CURVE

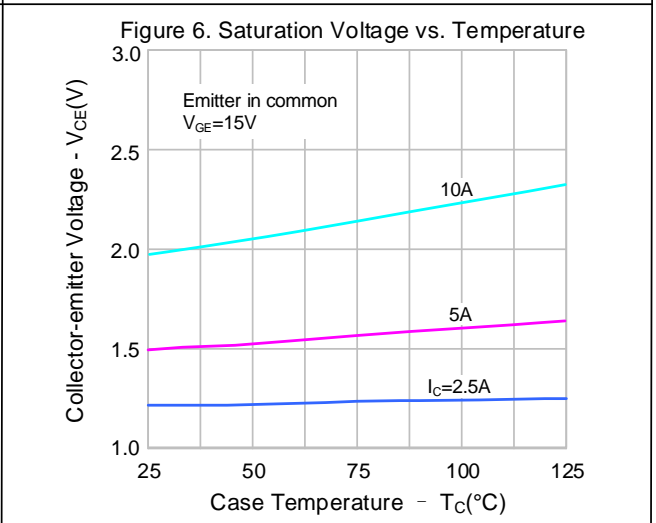
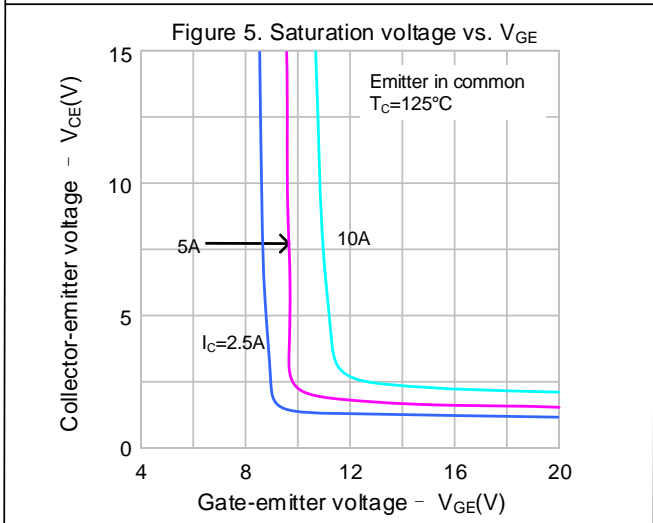
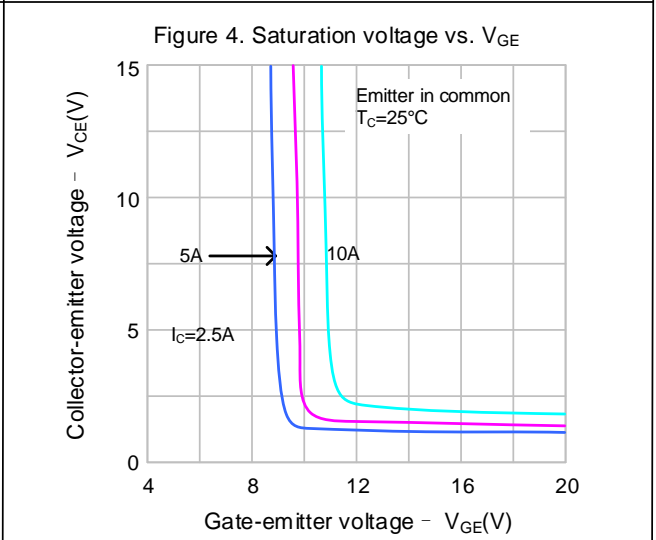
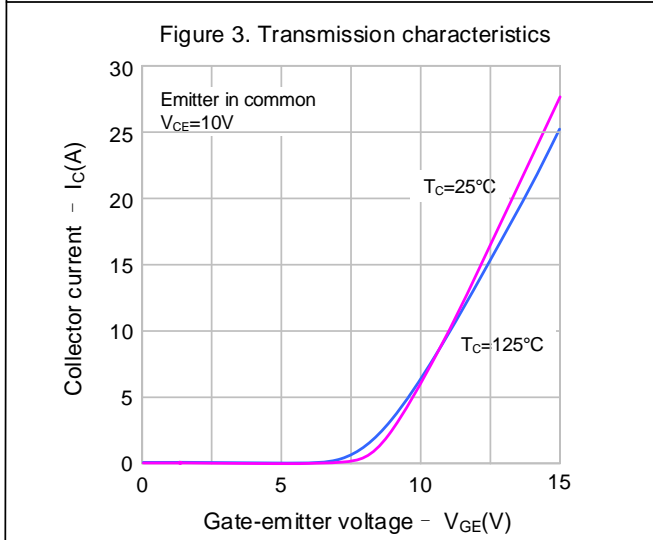
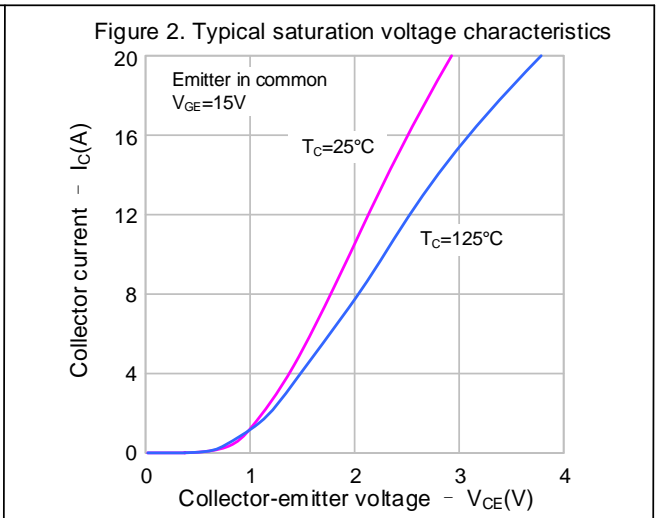
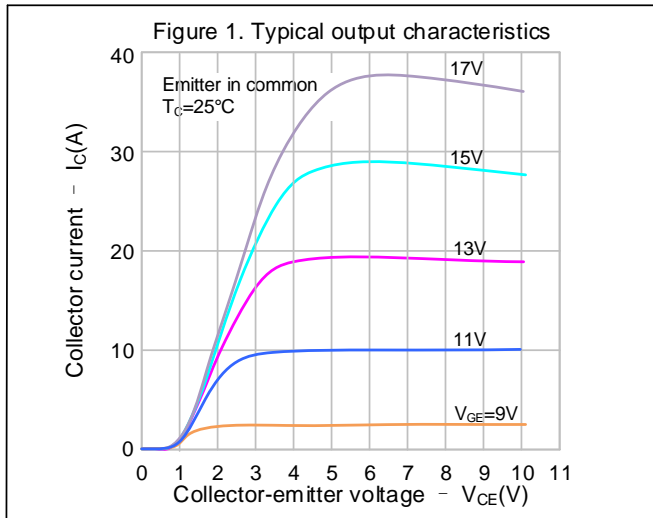

TYPICAL CHARACTERISTICS CURVE (CONTINUED)

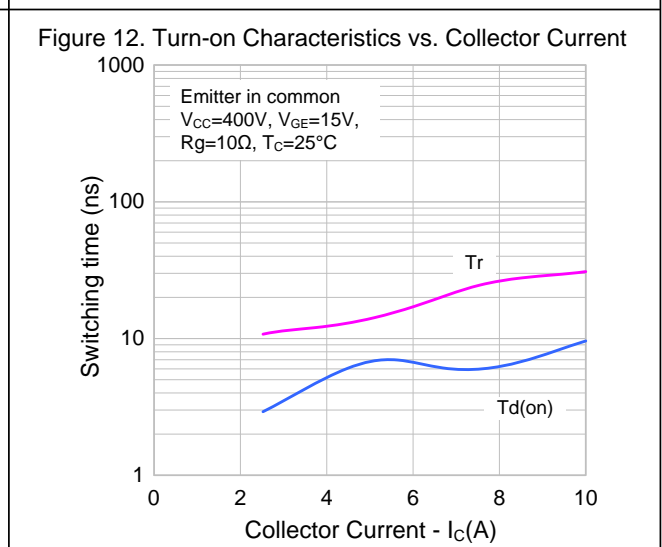
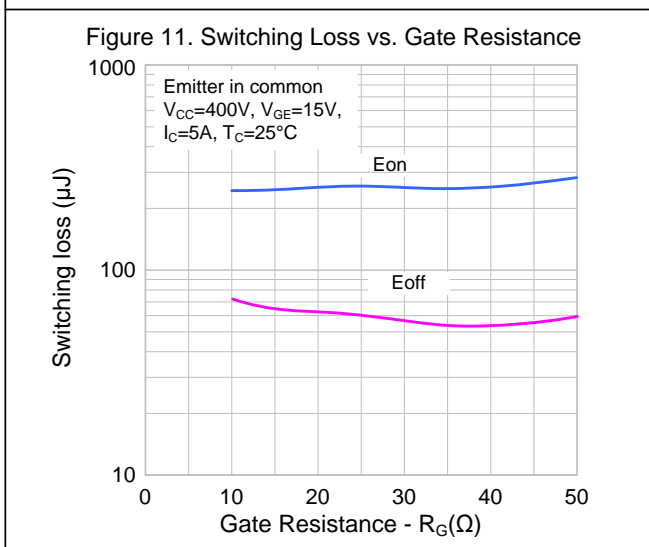
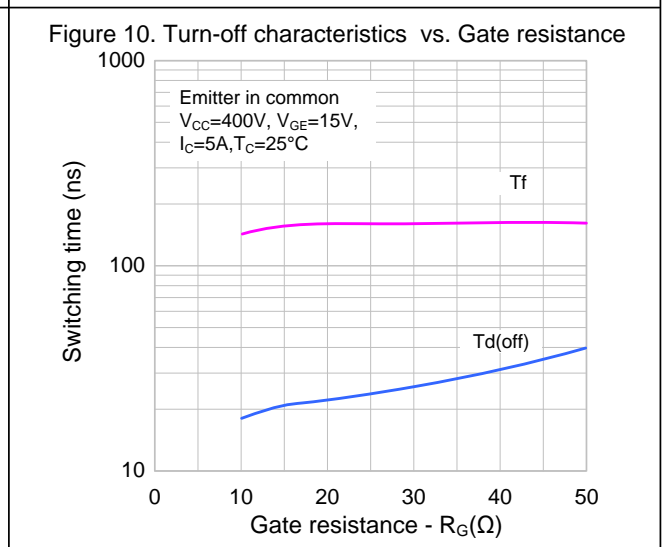
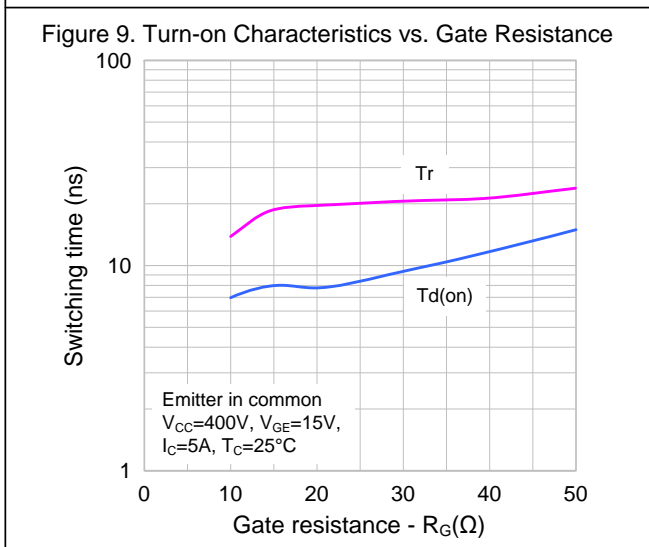
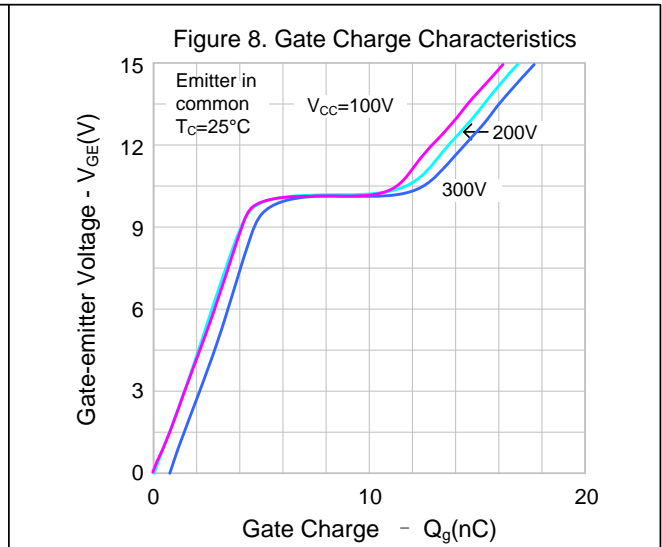
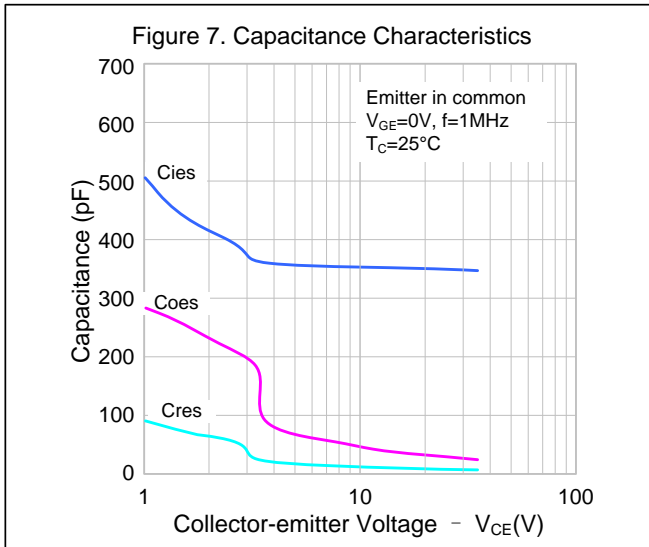

TYPICAL CHARACTERISTICS CURVE (CONTINUED)

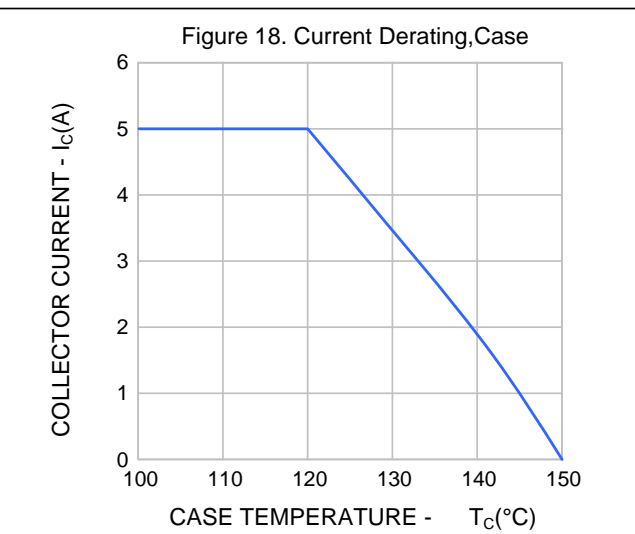
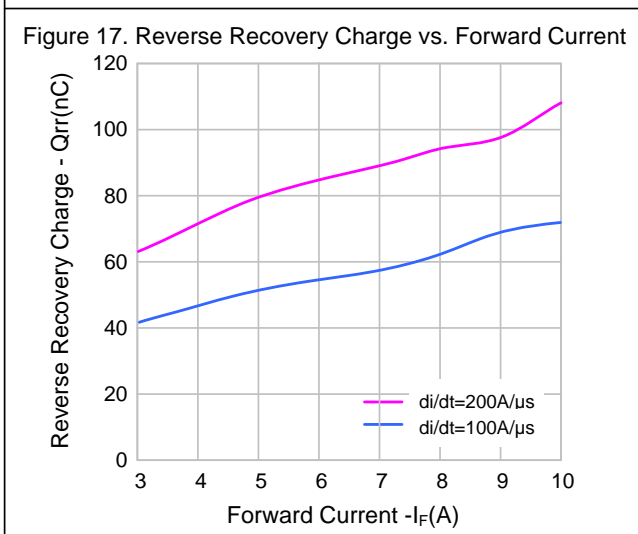
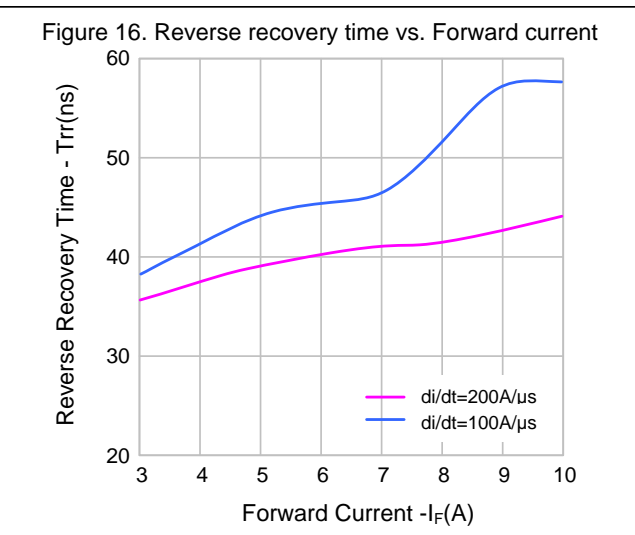
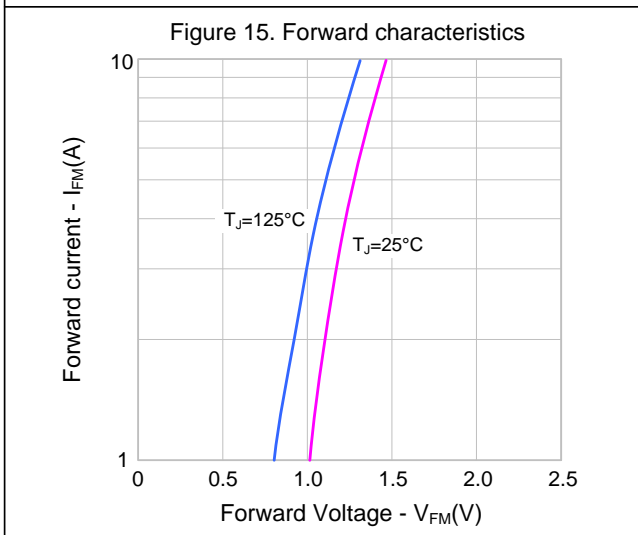
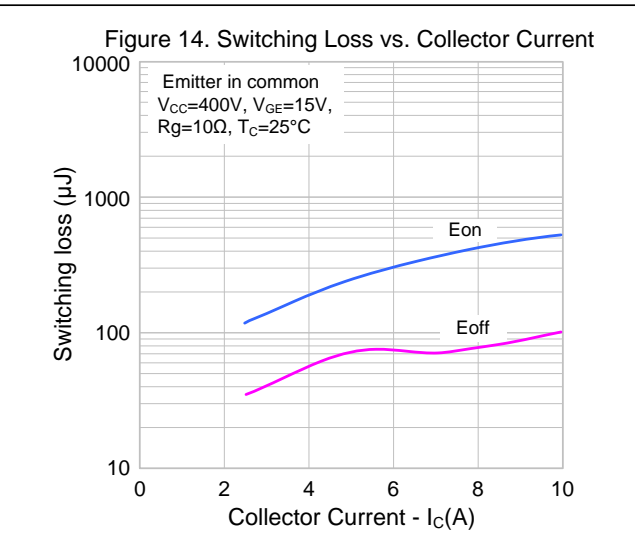
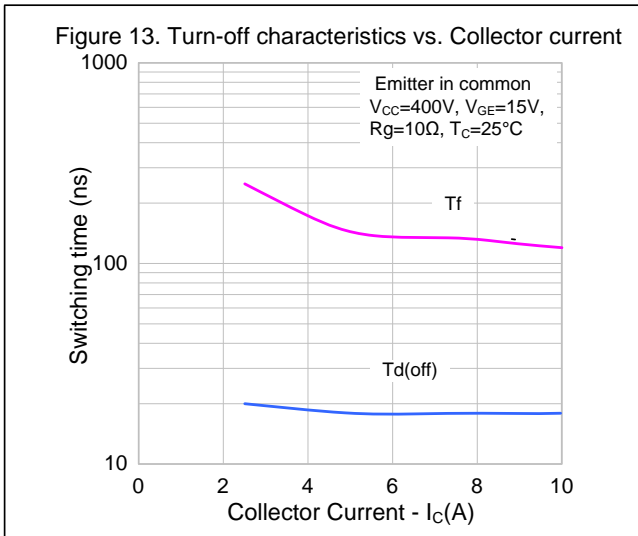

TYPICAL CHARACTERISTICS CURVE (CONTINUED)

Figure 19. Max. Safe Operating Area(SGTP5T60SD1D)

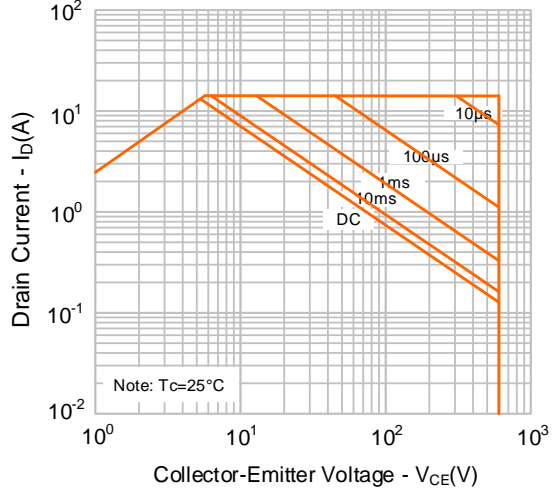

Figure 20. Max. Safe Operating (SGTP5T60SD1F)

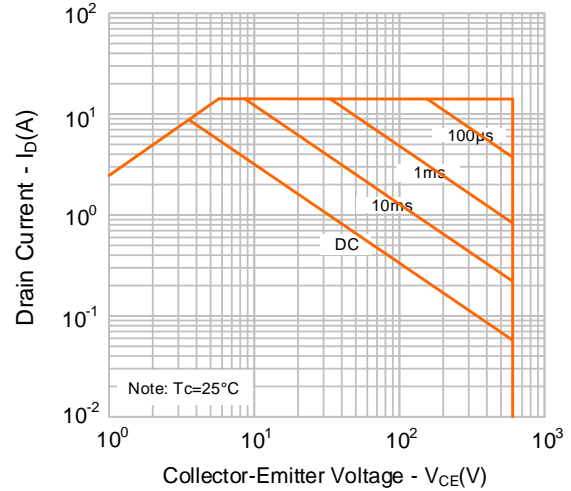
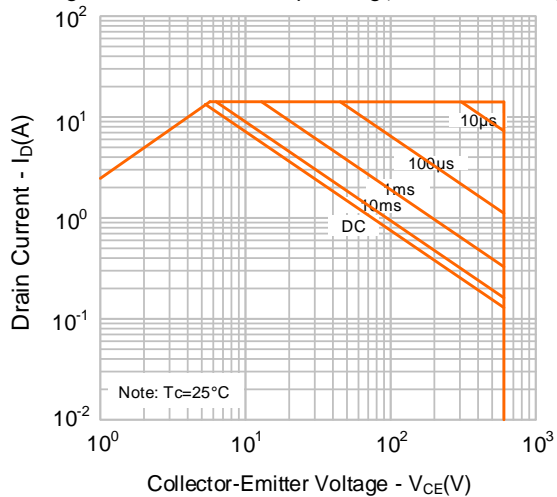
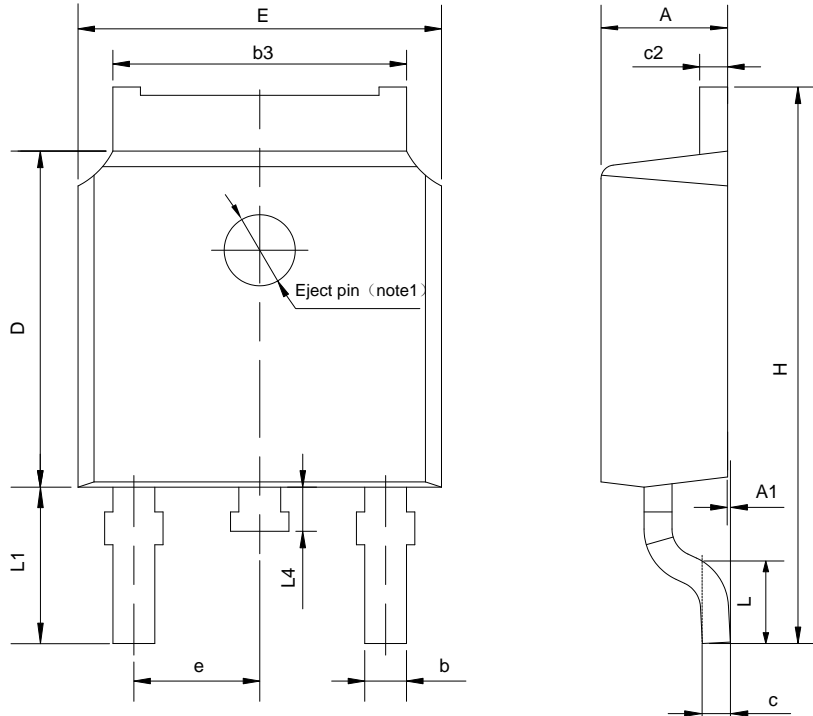

Figure 21. Max. Safe Operating(SGTP5T60SD1S)



PACKAGE OUTLINE

TO-252-2L UNIT: mm



SYMBOL	MILLIMETER		
	MIN	NOM	MAX
A	2.10	2.30	2.50
A1	0	—	0.127
b	0.66	0.76	0.89
b3	5.10	5.33	5.46
c	0.45	—	0.65
c2	0.45	—	0.65
D	5.80	6.10	6.40
E	6.30	6.60	6.90
e	2.30TYP		
H	9.60	10.10	10.60
L	1.40	1.50	1.70
L1	2.90REF		
L4	0.60	0.80	1.00

NOTE1 : There are two conditions for this position:has an eject pin or has no eject pin.

TO-220F-3L UNIT: mm

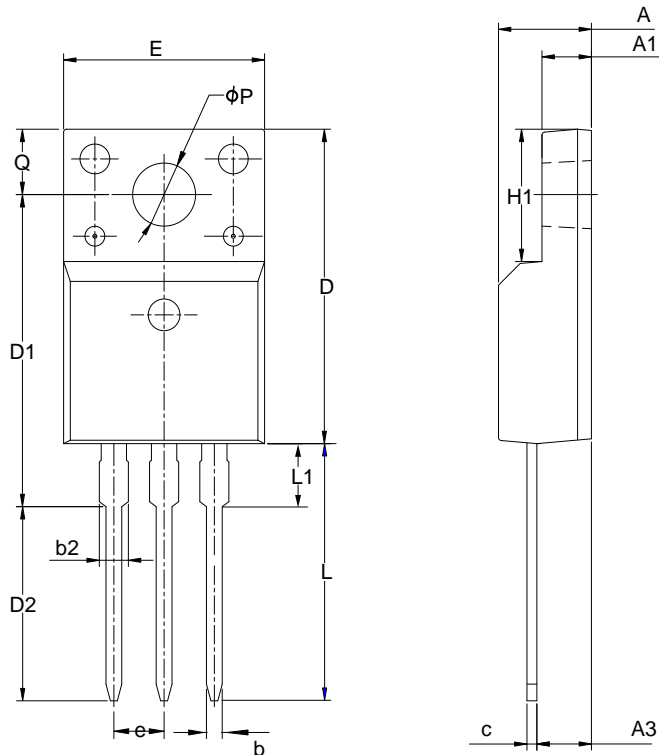

SYMBOL	MILLIMETER		
	MIN	NOM	MAX
A	4.42	4.70	5.02
A1	2.30	2.54	2.80
A3	2.50	2.76	3.10
b	0.70	0.80	0.90
b2	—	—	1.47
c	0.35	0.50	0.65
D	15.25	15.87	16.25
D1	15.30	15.75	16.30
D2	9.30	9.80	10.30
E	9.73	10.16	10.36
e	2.54BSC		
H1	6.40	6.68	7.00
L	12.48	12.98	13.48
L1	—	—	3.50
ϕP	3.00	3.18	3.40
Q	3.05	3.30	3.55

PACKAGE OUTLINE (CONTINUED)

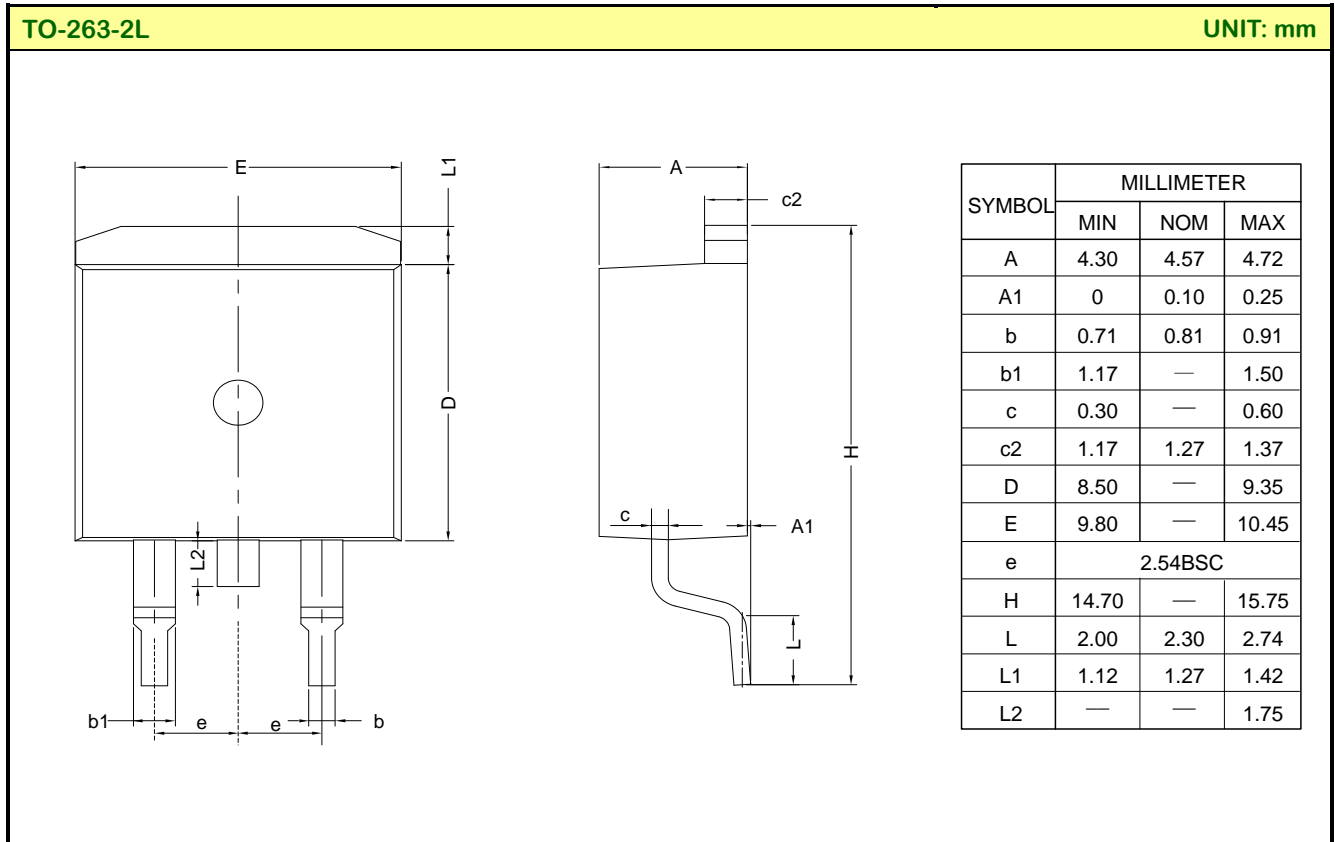

Important notice :

1. The instructions are subject to change without notice !
2. Customers should obtain the latest relevant information before placing orders and should verify that such information is complete and current. Please read the instructions carefully before using our products, including the circuit operation precautions.
3. Our products are consumer electronic products or the other civil electronic products.
4. When using our products, please do not exceed the maximum rating of the products, otherwise the reliability of the whole machine will be affected. There is a certain possibility of failure or malfunction of any semiconductor product under specific conditions. The buyer is responsible for complying with safety standards and taking safety measures when using our products for system design, sample and whole machine manufacturing, so as to avoid potential failure risk that may cause personal injury or property loss.
5. It is strongly recommended to identify the trademark when buying our products. Please contact us if there is any question.
6. Product promotion is endless, our company will wholeheartedly provide customers with better products!
7. Website: <http://www.silan.com.cn>

Part No.: SGTP5T60SD1D(F)(S) Document Type: Datasheet
Copyright: HANGZHOU SILAN MICROELECTRONICS CO.,LTD Website: <http://www.silan.com.cn>

Rev.: 1.7

Revision History:

1. Update SOA
-

Rev.: 1.6

Revision History:

1. Modify figure 10, $I_C=5A$
-

Rev.: 1.5

Revision History:

1. Add short circuit protection time
 2. Update the template of datasheet
-

Rev.: 1.4

Revision History:

1. Increases ambient thermal resistance
-

Rev.: 1.3

Revision History:

1. Update NOMENCLATURE
-

Rev.: 1.2

Revision History:

1. Add Fig 18
 2. Add TO-263-2L and TO-220F-3L
-

Rev.: 1.1

Revision History:

1. Modify the value of V_{GE}
-

Rev.: 1.0

Revision History:

1. First release
-
-