

LEPCOS (North-West Laboratory)

http://ferrite.ru Tel/fax +7-812-369-11-54

St-Petersburg, Russia

REVISIONS

REV	SYM	DRAFTER	CHECKER	DATE
①		K.F.YANG	W.H.HSU	06/16/06
②		S.Y.TANG	W.H.HSU	09/25/07
③				

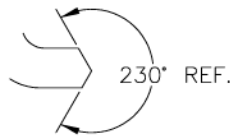
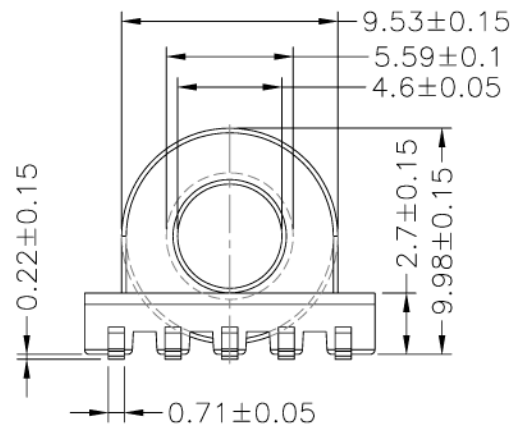
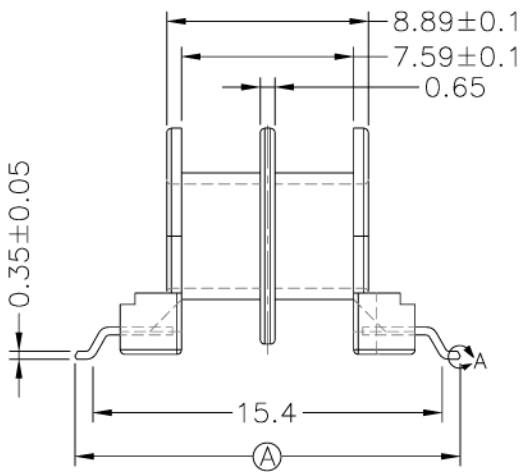
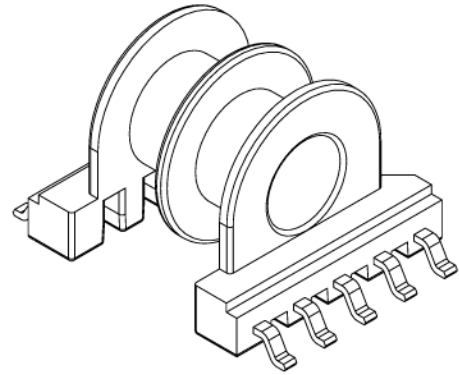
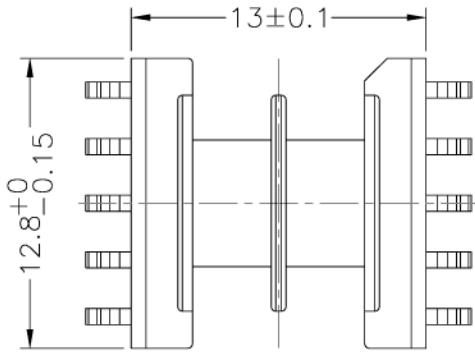

DETAIL:A
PATENTED

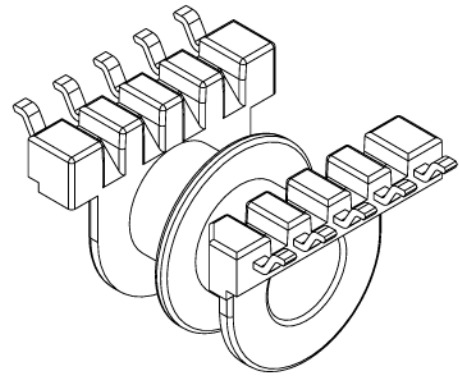
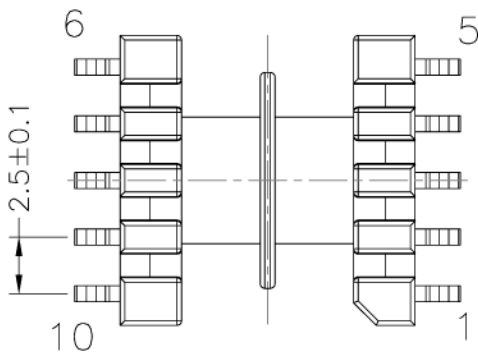

③ Notes: Pull Strenght 1.0 kg (min)

DWG NO. Bobbin EP13 2 sec 10 pin SMD E-014-1

PART NO.	MATERIAL (BOBBIN)	MATERIAL (TERMINAL)	TERMINAL (PLATING)	PIN ALLOCATION	NOTE
E-014-1	PM-9630	P.B	Sn	ALL PIN (A) = 16.99±0.15	

TOLERANCE: .X±0.15 .XX±0.10 .XXX±0.05 UNIT : m / m SCALE 3: 1

Finish: 1. Pb wire Immersion Sn on terminal : Thickness:Sn plating,100,5 μm (200 μ inches) min,Base nickel 0.625 μm (25 μ inches) min.
2. CP wire Immersion Sn on terminal : Thickness:Sn plating,100,5 μm (200 μ inches) min.
3. Coplanarity deviation: 0.10 mm (0.004 inches) max.

REV 2