



H cores 31 x 19 x 7

Effective core parameters

SYMBOL	PARAMETER	VALUE	UNIT
	mass	16.2	gr
Ve	effective volume	3297	mm <sup>3</sup>
le	effective length	80.1	mm
Ae	effective area	61.2	mm <sup>2</sup>

Characteristic

GRADE	Z1 Impedance	Z2 Impedance
	Instrument: HP4291B Frequency: f=25MHz Coil: N=1Ts Φ0.4mm × 90mm Temperature: T=(25±2)°C	Instrument: HP4291B Frequency: f=100MHz Coil: N=1Ts Φ0.4mm × 90mm Temperature: T=(25±2)°C
DN65H	26 min	72 min

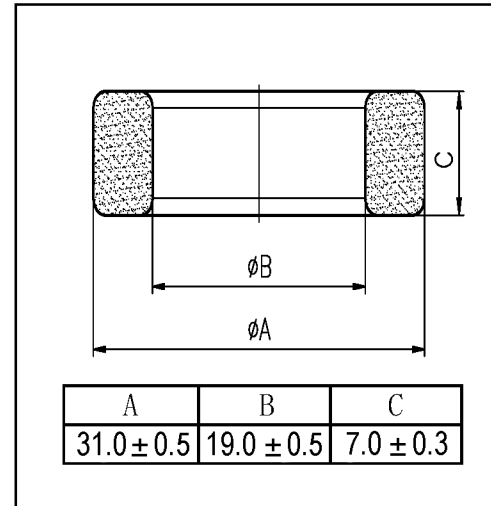

DN65H Material Characteristics

Item	Symbol	Condition	Value	Unit
Initial Permeability	$\mu_i$		650 ± 25%	
Working Frequency	f	25°C	0.1 - 1.5	MHz
Relative Loss Factor	$\tan \delta / \mu_i$	25°C	20 0.1MHz	$\times 10^{-6}$
Saturation Magnetic Flux Density	Bs	25°C	330 1600A/m	mT
Remanence	Br	25°C	150	mT
Coercive Force	Hc	25°C	35	A/m
Relative Temperature Coefficient	$a \mu r$		2-8	$\times 10^{-6}/^\circ C$ 20°C~60°C
Curie Temperature	Tc		>150	°C
Electrical Resistivity	$\rho$	25°C	>10 <sup>5</sup>	$\Omega \cdot m$
Density	d	25°C	5.1	g/cm <sup>3</sup>

