



H cores 31 x 19 x 8

Effective core parameters

SYMBOL	PARAMETER	VALUE	UNIT
	mass	19.2	gr
Ve	effective volume	3768	mm ³
le	effective length	80.1	mm
Ae	effective area	61.2	mm ²

Characteristic

GRADE	Z1 Impedance	Z2 Impedance
	Instrument: HP4291B Frequency: f=25MHz Coil: N=1Ts Φ0.4mm × 90mm Temperature: T=(25±2)°C	Instrument: HP4291B Frequency: f=100MHz Coil: N=1Ts Φ0.4mm × 90mm Temperature: T=(25±2)°C
DN5H	17 min	73 min

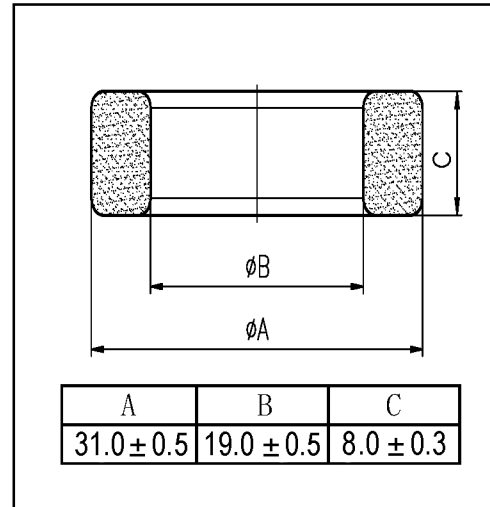

DN5H Material Characteristics

Item	Symbol	Condition	Value	Unit
Initial Permeability	μ_i		50 ± 25%	
Working Frequency	f	25°C	0.5-55	MHz
Relative Loss Factor	$\tan \delta / \mu_i$	25°C	250 30MHz	$\times 10^{-6}$
Saturation Magnetic Flux Density	Bs	25°C	370 4000A/m	mT
Remanence	Br	25°C	280	mT
Coercive Force	Hc	25°C	300	A/m
Relative Temperature Coefficient	$a \mu_r$		15-50	$\times 10^{-6} / ^\circ C$ 20°C ~ 60°C
Curie Temperature	Tc		>300	°C
Electrical Resistivity	ρ	25°C	>10 ⁵	$\Omega \cdot m$
Density	d	25°C	5.1	g/cm ³

