

LEPCOS (North-West Laboratory)

http://ferrite.ru Tel/fax +7-812-369-11-54

St-Petesburg, Russia

REVISIONS

REV	SYM	DRAFTER	CHECKER	DATE
△0		Y.G.HSU	W.H.HSU	06/07/07
△1		S.Y.TANG	W.H.HSU	06/14/07
△2		S.Y.TANG	W.H.HSU	08/16/07

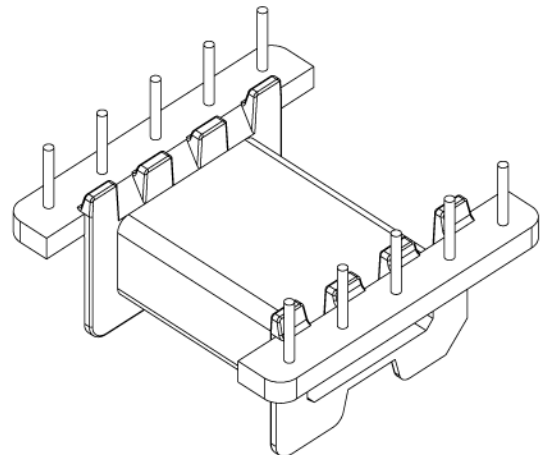
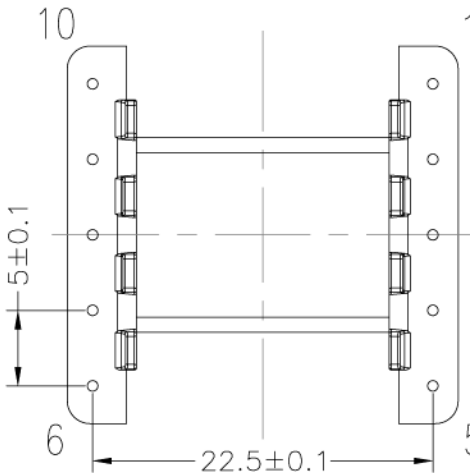
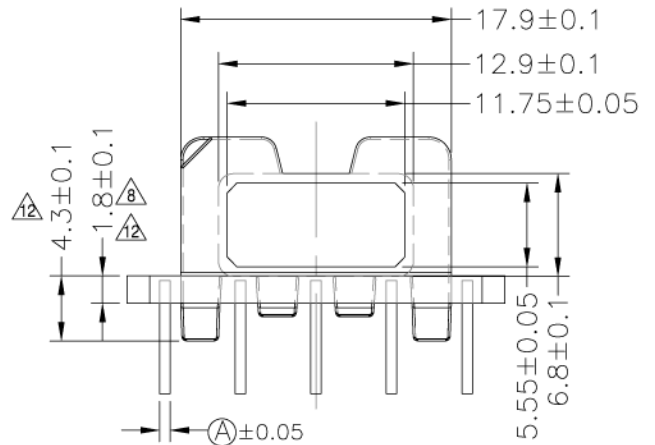
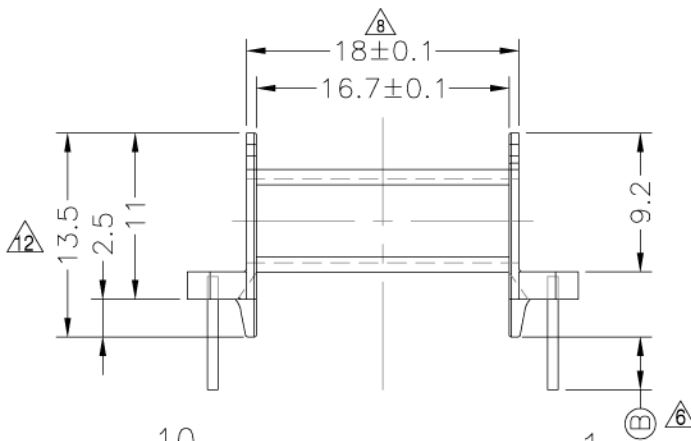
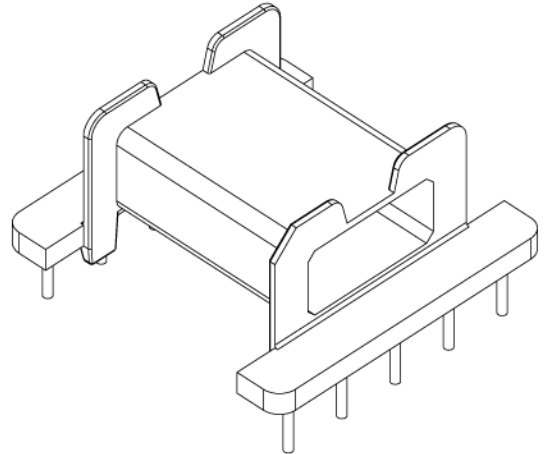
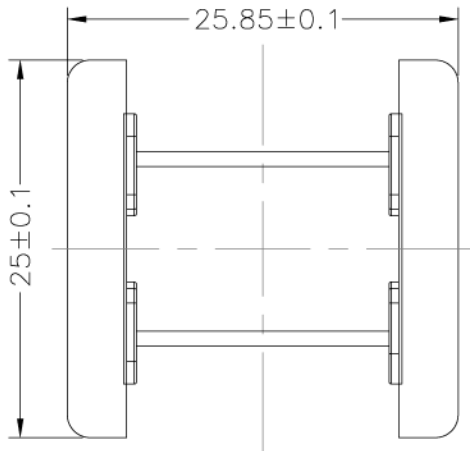

DWG NO. EFD25 Bobbin 1 sec 10 pin E-035

PART NO.	MATERIAL (BOBBIN)	MATERIAL (TERMINAL)	TERMINAL (PLATING)	PIN ALLOCATION	NOTE
E-035	PM-9630	C.P WIRE	Sn	ALL PIN (A)= ϕ 0.7 (B)= $3.5+0.5/0$	
					15-1013-00
					15-1013-01
					MG515-00122

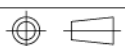

TOLERANCE: .X±0.15 .XX±0.10 .XXX±0.05

UNIT : m / m

SCALE 2 : 1

Finish: 1.Pb wire Immersion Sn on terminal : Thickness:Sn plating,100,5 μm (200 μ inches) min,Base nickel 0.625 μm (25 μ inches) min.
 2.CP wire Immersion Sn on terminal : Thickness:Sn plating,100,5 μm (200 μ inches) min.
 3. Coplanarity deviation: 0.10 mm (0.004 inches) max.

REV 12