

PHASED OUT

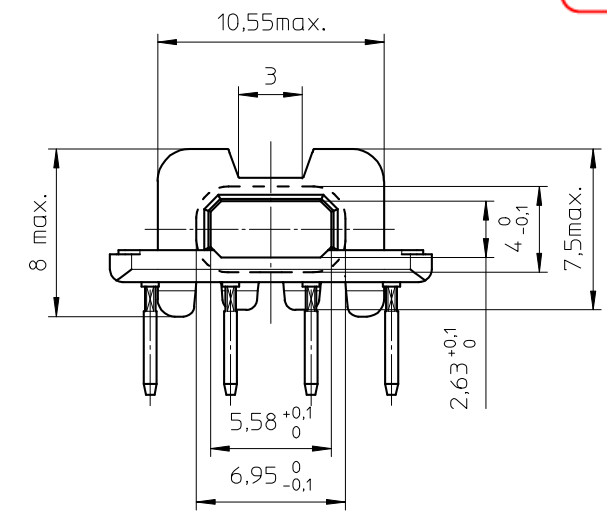

Coil former material: Sumikon PM-9630 (PF), glass-reinforced.
 UL file number: E41429 - UL94V-0.

Pin material: CuSn - Ni flash, Sn plated.

Max. operating temp.: acc. to IEC 60 085 class H, 180°C.

Resistance to soldering heat: acc. to IEC 60 068-2-20 Part 2, Test Tb, method 1B, 350°C-3.5s.

Solderability: acc. to IEC 60 068-2-20 Part 2, Test Ta, method 1, 235°C-2s.

Min. winding area: 14,8 mm².

Mean length of turn: 26,3 mm.

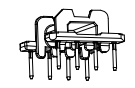

CLASSNO.				07-10-19	
07-10-19		CSH-EFD15-1S-8P-IZ		4322 021 06821	
NAME NAAM	A.Wojtasz	SUPERS. VERV.	001	SPSH BL	112 - 001
MPA	CHECK CONTR.	DAT.	07-10-19	Property of Eigenaam van	© FERROXCUBE 2007
				069	A3