

SPECIFICATION FOR APPROVAL

Material

Production:	Sendust Cores
P/N:	FAS106075A
AL:	94(nH/N ²)±8%
Material:	75 μ
Coating Color:	Black
Coating material:	epoxy
Coating Breakdown Voltage:	1000V, 0.5mA, 2Sec

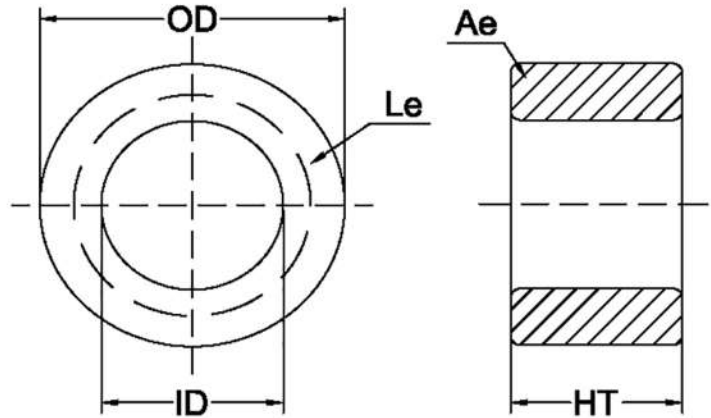

Physical Characteristics

Before Coating			After Coating			Le(cm)	Ae(cm ²)	V(cm ³)	W(cm ²)	Weight (g) (ref.)	Box Quantity (Pieces)
OD(Max.) in/mm	ID(Min.) in/mm	Ht(Max.) in/mm	OD(Max.) mm	ID(Min.) mm	Ht(Max.) mm						
1.059 26.90	0.579 14.70	0.441 11.20	27.70	14.10	11.99	6.350	0.654	4.150	1.561	25.5	504

Electrical Parameters(Typical) Temperature(25°C ± 2°C)

Test Item	Test Condition	Value(Typical)	Test Instrument
Inductance	φ 0.8mm/34Ts, 20kHz/1V, I=0A (Evenly full windings)	108.7 μH ± 8%	CH3302
DC-Bias	φ 0.8mm/34Ts, 20kHz/1V, I=7.4A(H=50Oe) (Evenly full windings)	63.0 μH (Min.)	WK3255B+WK3265B
Core Loss	50kHz/1000Gs	350mW/cm ³ (Max.)	SY-8219
Remarks	Set the internal resistance of LCR meter to 100Ω.		

Core Loss Curves(Typical)

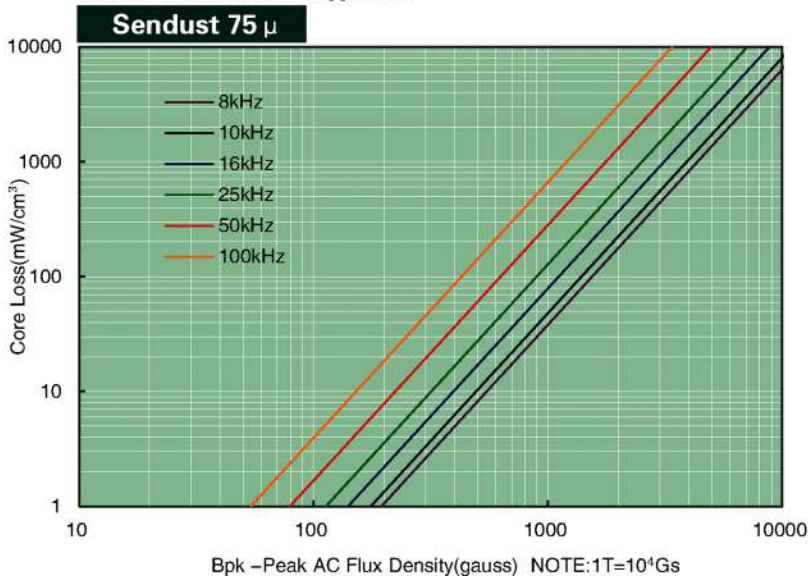

DC-Bias Curves(Typical)

