

FERROXCUBE

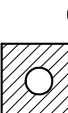

e

f

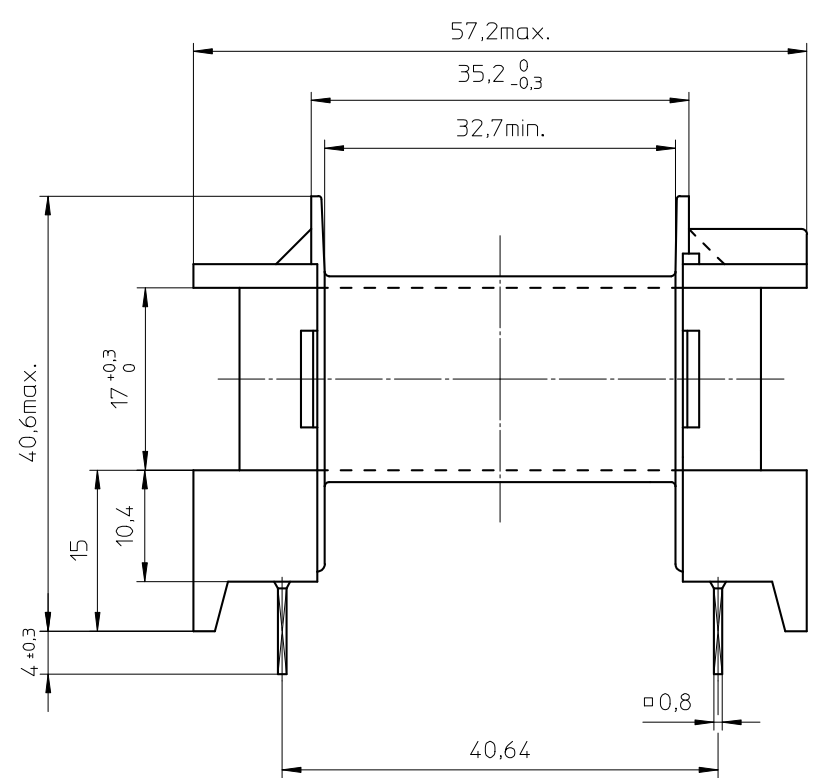
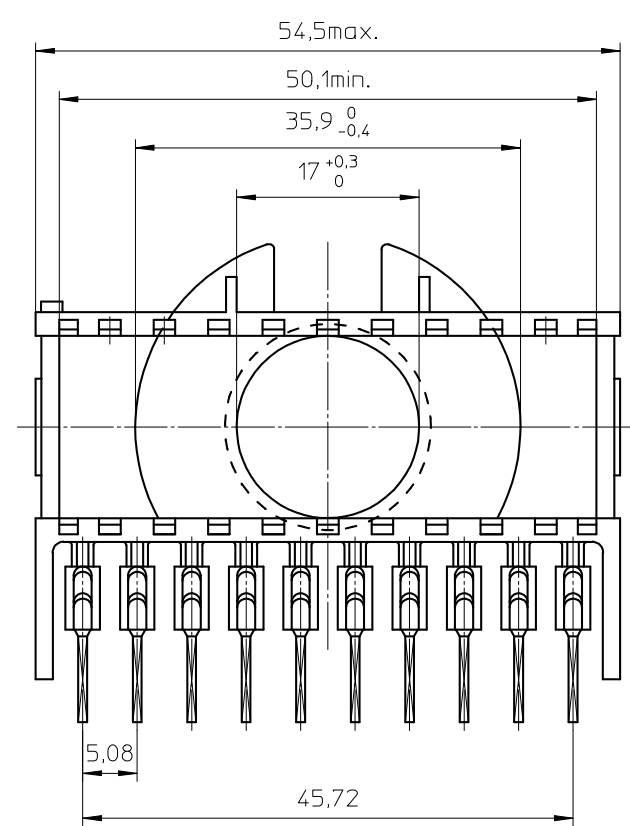

HOLE PATTERN:

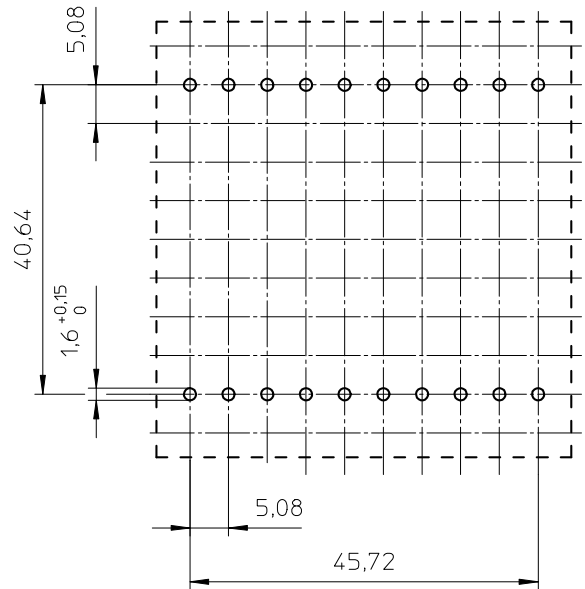

Coil former material: Valox 420SE0 (PBT), glass-reinforced.
 UL file number: E45329(R) - UL94V-0.
 Pin material: Copper-plated steel wire, Sn plated.
 Max. operating temp.: acc. to IEC 60 085 class F, 155°C.
 Resistance to soldering heat: acc. to IEC 60 068-2-20 Part 2, Test Tb, method 1B, 350°C - 3,5sec
 Solderability: acc. to IEC 60 068-2-20 Part 2, Test Ta, method 1, 235°C - 2sec.
 Min. winding area: 269 mm².
 Mean length of turn: 86 mm.

CLASSNO.		CPH-ETD49-1S-20P-C		4322 021 01671		2004-09-28
98-02-25						2006-06-12
						2008-06-19
						2015-08-14
						2015-09-29
NAME NAAM	M.Marszalek	SUPERS. VERV.	001	SP/SH BL/BL	112 - 001	069
MPA	CHECK CONTR.	DAT.	96-02-06	Property of Eigenaam van	© FERROXCUBE 2008	