

PHASED OUT

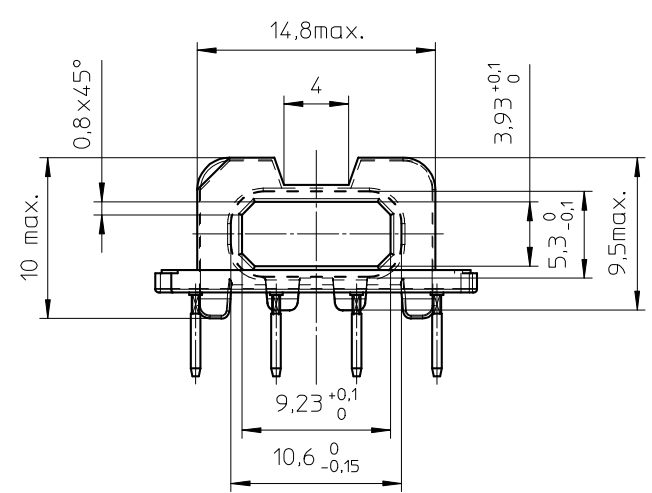

Coil former material: Sumikon PM9630 (PF), glass-reinforced.
 UL file number: E1429 - UL94V-0.

Pin material: CuSn - Ni flash, Sn plated.

Max. operating temp.: acc. to IEC 60 085 class H, 180°C.

Resistance to soldering heat: acc. to IEC 60 068-2-20 Part 2, Test Tb, method 1B, 350°C-3,5s.

Solderability: acc. to IEC 60 068-2-20 Part 2, Test Ta, method 1, 235°C-2s.

Min. winding area: 26,4 mm².

Mean length of turn: 36,5 mm.

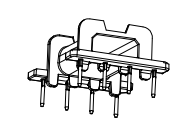

CLASSNO.		07-11-05	
NAME		CSH-EFD20-1S-8P-IZ	
VERV.		4322 021 06931	
NAME	SUPERS.	SP/SH	
NAAM	VERV.	BL/BL	
MPA	CHECK	001	110 - 001
CONTR.	DAT.	07-11-05	069
Property of		A3	
Eigendom van		© FERROXCUBE 2007	