

## Features

- CRM G2 SiC MOSFET Technology
- High Blocking Voltage with Low On-Resistance
- High Speed Switching with Low Capacitances
- Avalanche Ruggedness
- Fast Reverse Recovery

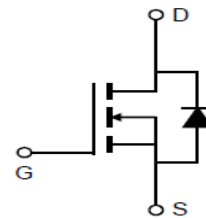
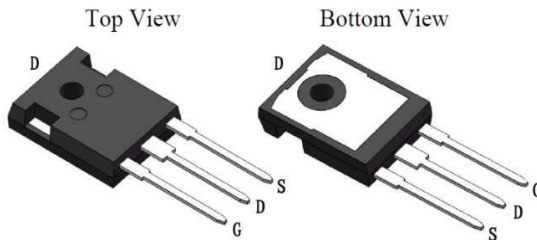
## Product Summary

VDS	1200V
R <sub>DS(on)_typ</sub>	17mΩ
I <sub>D</sub>	115A

## Applications

- Solar Inverters
- High Voltage DC/DC Converters
- On Board Charger(OBC)
- EV Charger

**100% Avalanche Tested**



## Package Marking and Ordering Information

Part #	Marking	Package	Packing	Qty
CRXQ17M120G2Z	CRXQ17M120G2Z	TO-247	Tube	25pcs

## Absolute Maximum Ratings

Parameter	Symbol	Value	Unit
Drain-source voltage	V <sub>DSmax</sub>	1200	V
Continuous drain current V <sub>GS</sub> =15V, T <sub>C</sub> = 25°C V <sub>GS</sub> =15V, T <sub>C</sub> = 100°C	I <sub>D</sub>	115 82	A
Pulsed drain current (T <sub>C</sub> = 25°C, t <sub>p</sub> limited by T <sub>jmax</sub> )	I <sub>D(pulse)</sub>	288	A
Avalanche energy, single pulse (L=10mH, R <sub>g</sub> =25Ω)	E <sub>AS</sub>	1130	mJ
Gate-Source voltage (dynamic) <sup>a1</sup>	V <sub>GSmax</sub>	-10/+22	V
Gate-Source voltage (static) <sup>a2</sup>	V <sub>GSop</sub>	-5/+18	V
Power dissipation (T <sub>C</sub> =25°C, T <sub>J</sub> =175°C)	P <sub>D</sub>	312	W
Operating Junction and Storage Temperature	T <sub>j</sub> , T <sub>stg</sub>	-55...175	°C

a1: When using MOSFET Body Diode V<sub>GSmax</sub> = -5V/+22V

a2: MOSFET can also safely operate at 0/+18 V

## Thermal Resistance

Parameter	Symbol	Value	Unit
Thermal resistance, junction – case. Max	$R_{thJC}$	0.48	°C/W
Thermal resistance, junction – ambient. Max	$R_{thJA}$	40	

## Electrical Characteristic (at $T_j = 25\text{ }^\circ\text{C}$ , unless otherwise specified)

Parameter	Symbol	Value			Unit	Test Condition
		min.	typ.	max.		

### Static Characteristic

Drain-source breakdown voltage	$V_{(BR)DSS}$	1200	-	-	V	$V_{GS}=0V, I_D=250\mu A$
Gate threshold voltage	$V_{GS(th)}$	1.8	-	3.6	V	$V_{DS}=V_{GS}, I_D=25mA$
Zero gate voltage drain current	$I_{DSS}$	-	10	250	$\mu A$	$V_{DS}=1200V, V_{GS}=0V$ $T_j=25^\circ C$
		-	100	-		$T_j=175^\circ C$
Gate-source leakage current	$I_{GSS}$	-	-	250	nA	$V_{GS}=20V, V_{DS}=0V$
Drain-source on-state resistance	$R_{DS(on)}$	-	17	23	mΩ	$V_{GS}=15V, I_D=75A,$ $T_j=25^\circ C$
		-	32	-		$T_j=175^\circ C$
Transconductance	$g_{fs}$	-	59	-	S	$V_{DS}=20V, I_{DS}=75A$

### Dynamic Characteristic

Internal Gate resistance	$R_{G(int)}$	-	0.9	-	Ω	$f=1MHz$
Input Capacitance	$C_{iss}$	-	5506	-	pF	$V_{GS}=0V, V_{DS}=1000V,$ $f=1MHz$
Output Capacitance	$C_{oss}$	-	205	-		
Reverse Transfer Capacitance	$C_{rss}$	-	15	-		
Coss Stored Energy	$E_{oss}$	-	119	-		
Gate Total Charge	$Q_g$	-	212	-	nC	$V_{GS}=-5/15V$ $V_{DS}=800V$ $I_D=75A$
Gate-Source charge	$Q_{gs}$	-	72	-		
Gate-Drain charge	$Q_{gd}$	-	56	-		
Turn-on delay time	$t_{d(on)}$	-	134	-	ns	$V_{DD}=800V, I_D=75A$ $V_{GS}=-5V/15V,$ $R_G=2.5\Omega, L=100\mu H$
Rise time	$t_r$	-	49	-		
Turn-off delay time	$t_{d(off)}$	-	104	-		
Fall time	$t_f$	-	29	-		
Turn-On Switching Energy	$E_{(on)}$	-	4335	-	μJ	
Turn Off Switching Energy	$E_{(off)}$	-	1562	-		

## Body Diode Characteristic

Parameter	Symbol	Value			Unit	Test Condition
		min.	typ.	max.		
Body Diode Forward Voltage	$V_{SD}$	-	3.8	-	V	$V_{GS}=0V, I_F=37.5A$
		-	3.2	-	V	$V_{GS}=0V, I_F=37.5A, T_j=175^\circ C$
Continuous Diode Forward Current	$I_S$	-	-	115	A	$V_{GS}=0V$
Maximum Pulsed Current	$I_{S,max}$	-	-	288	A	pulse width $t_p$ limited by $T_{jmax}$
Body Diode Reverse Recovery Charge	$t_{rr}$	-	67	-	ns	di/dt=1000A/us $I_F=75A$ $V_{dd}=800V$ $T_j=25^\circ C$
	$Q_{rr}$	-	466	-	nC	
Body Diode Peak Reverse Recovery Current	$I_{rrm}$	-	13.7	-	A	
Body Diode Reverse Recovery Time	$t_{rr}$	-	86	-	ns	di/dt=1000A/us $I_F=75A$ $V_{dd}=800V,$ $T_j=175^\circ C$
Body Diode Reverse Recovery Charge	$Q_{rr}$	-	1619	-	nC	
Body Diode Peak Reverse Recovery Current	$I_{rrm}$	-	30	-	A	

## Typical Performance Characteristics

Fig 1. Output Characteristics (T<sub>j</sub>=-55°C)

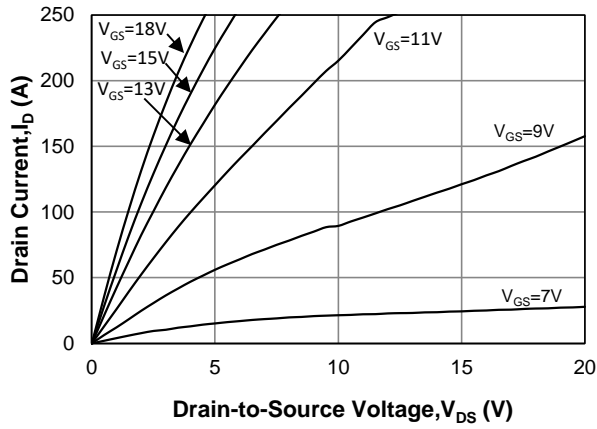


Fig 2. Output Characteristics (T<sub>j</sub>=25°C)

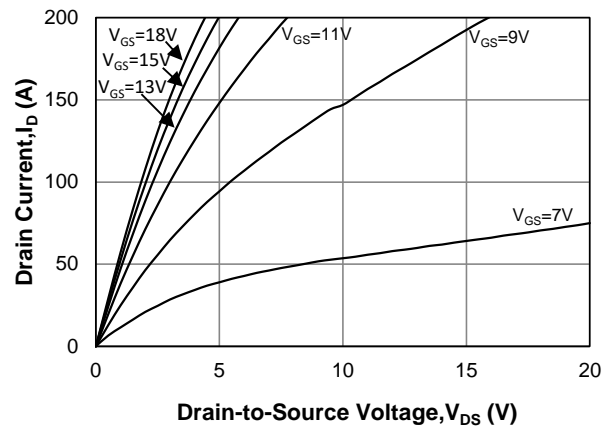


Fig 3. Output Characteristics (T<sub>j</sub>=175°C)

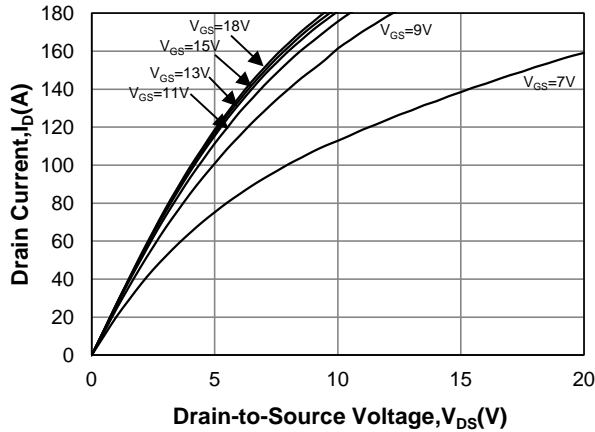


Fig 4: R<sub>ds(on)</sub> vs. Temperature

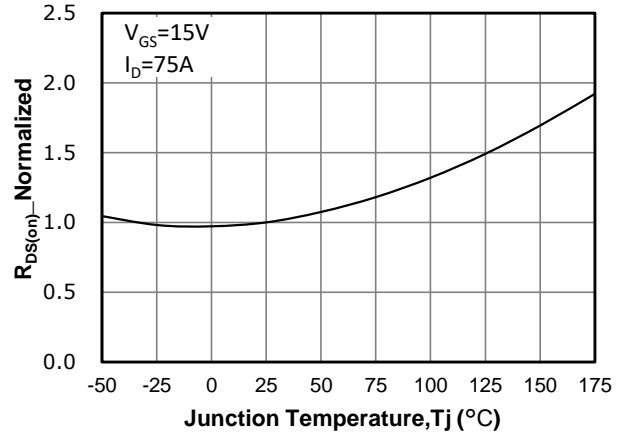


Fig 5: On-Resistance vs. Drain Current For Various Temperatures

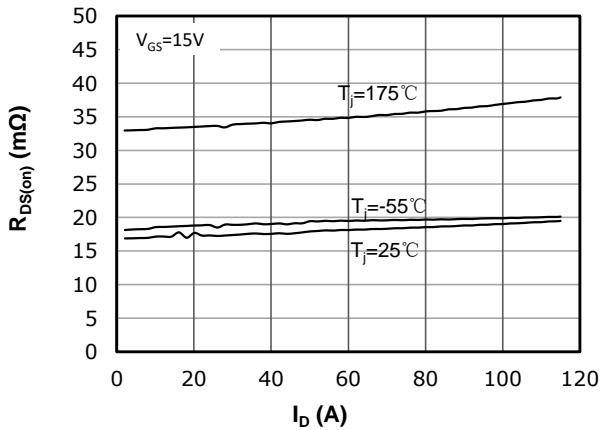
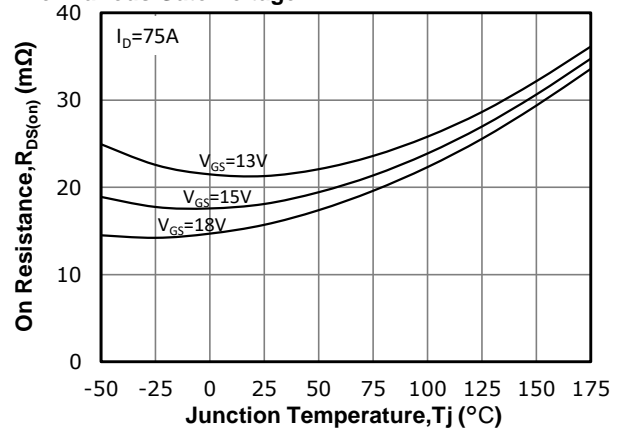
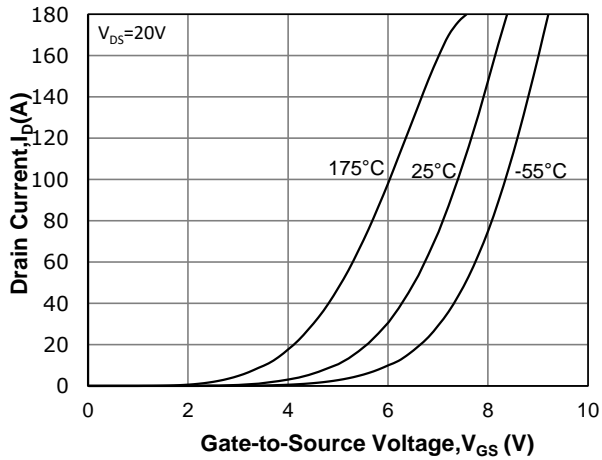


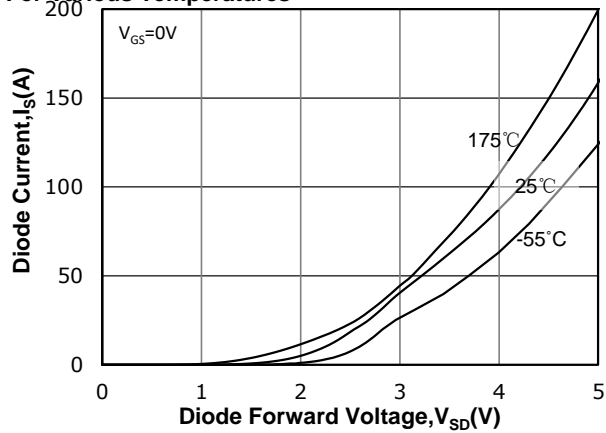
Fig 6: R<sub>ds(on)</sub> vs. Temperature For Various Gate Voltage



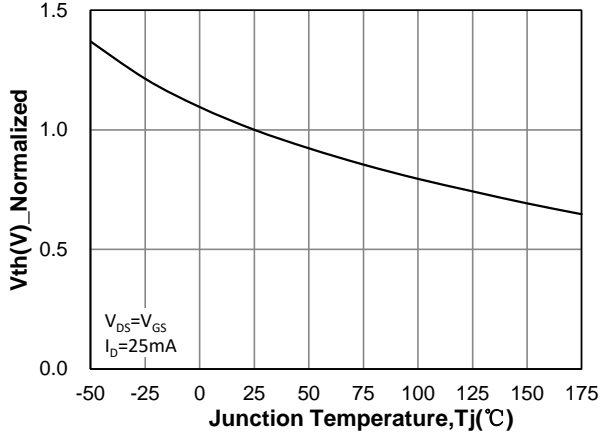
**Fig 7: Transfer Characteristics**



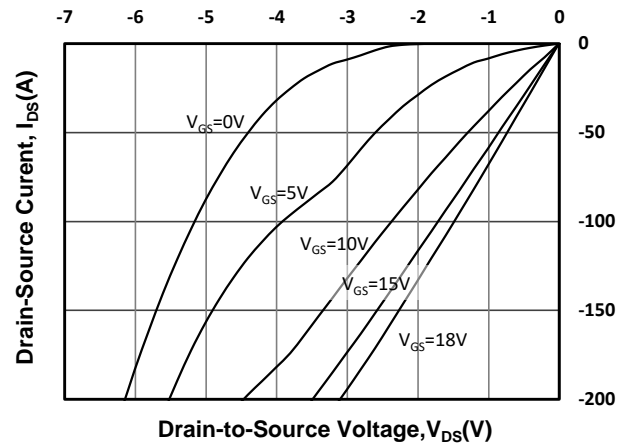
**Fig 8: Body-diode Forward Characteristics For Various Temperatures**



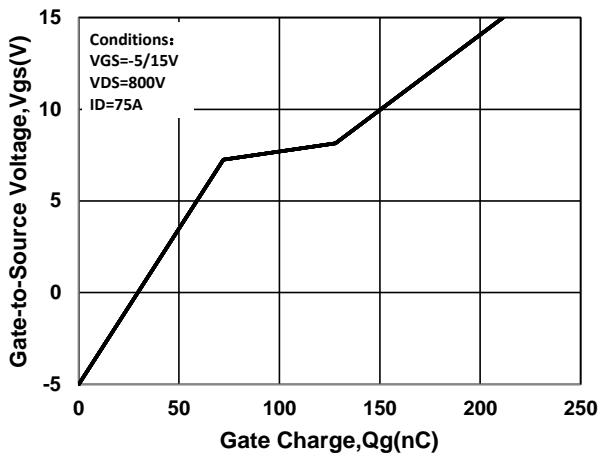
**Fig 9: V\_GS(th) Vs T\_j Characteristics**



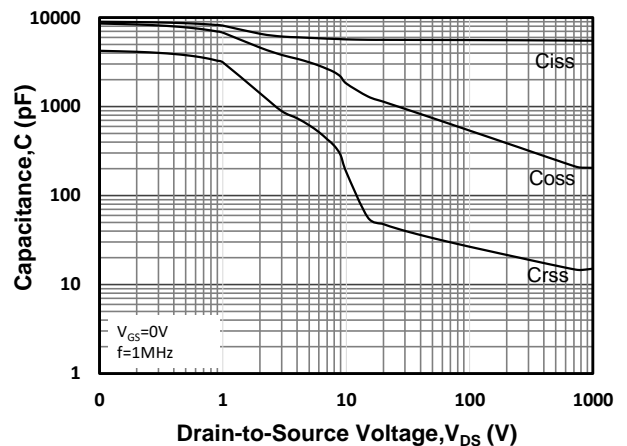
**Fig 10: 3rd Quadrant Characteristic at 25°C**



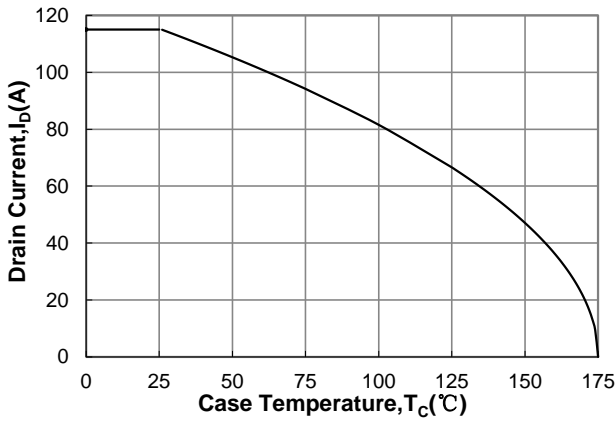
**Fig 11: Ggate Charge Characteristics**



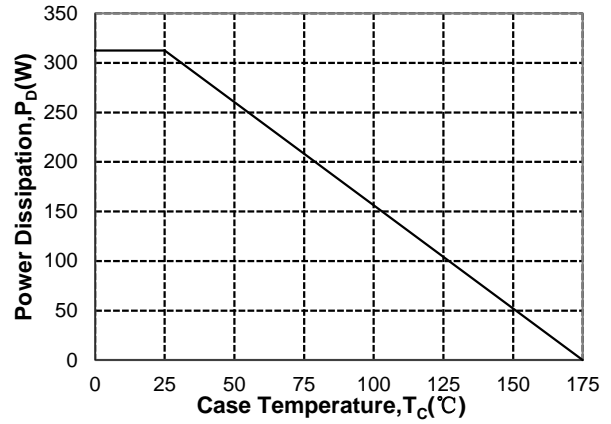
**Fig 12: Capacitance Characteristics**



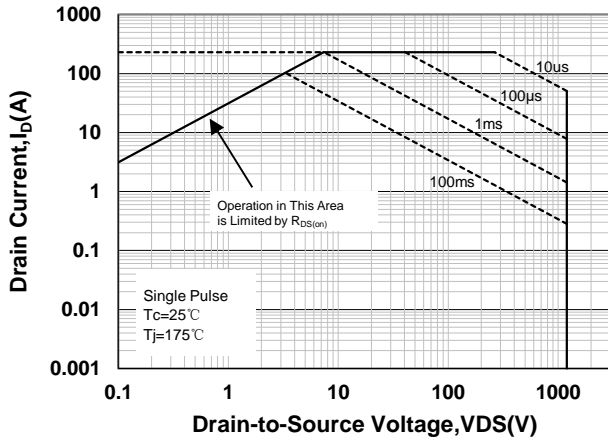
**Fig 13: Continuous Drain Current vs. Case Temperature**



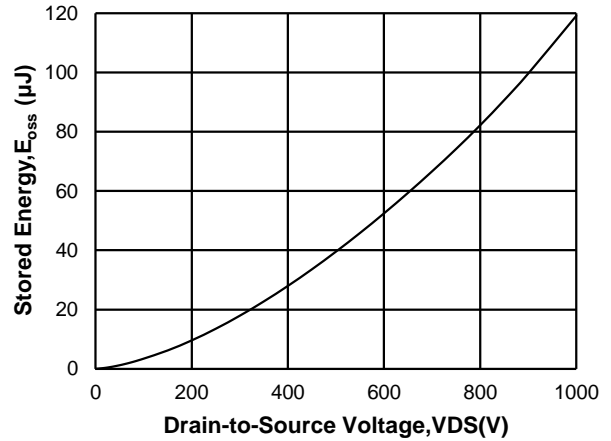
**Fig 14: Maximum Power Dissipation vs. Case Temperature**



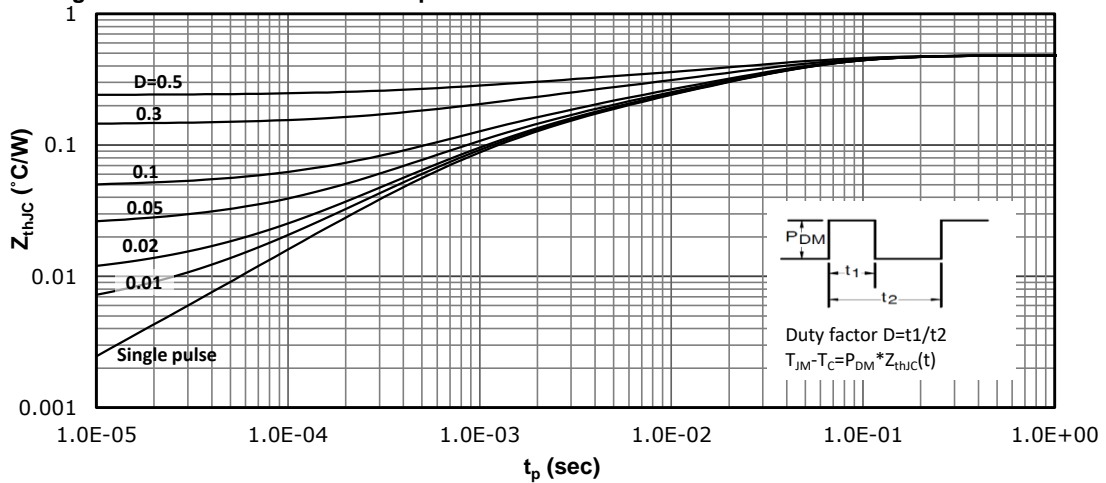
**Fig 15: Safe Operating Area**



**Fig 16: Output Capacitor Stored Energy**

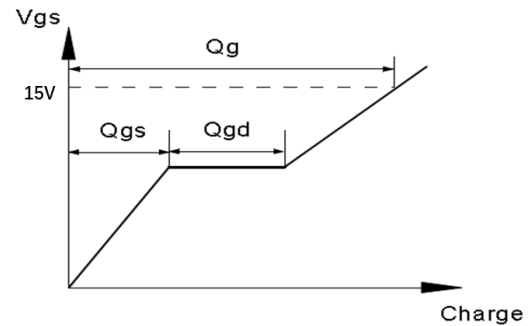
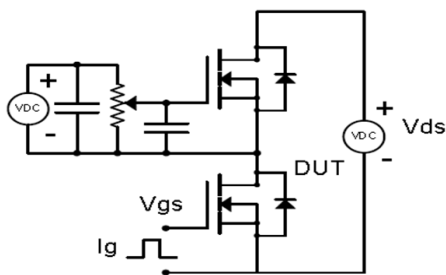


**Fig 17: Max. Transient Thermal Impedance**

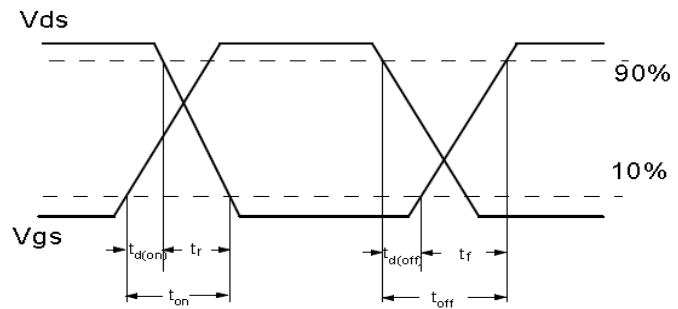
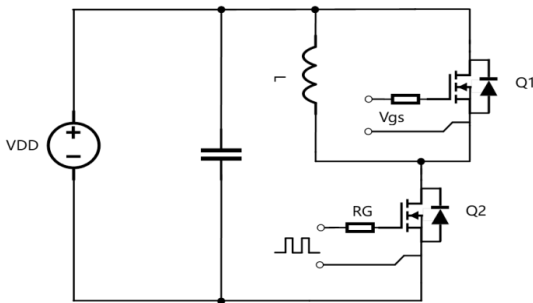


## Test Circuit & Waveform

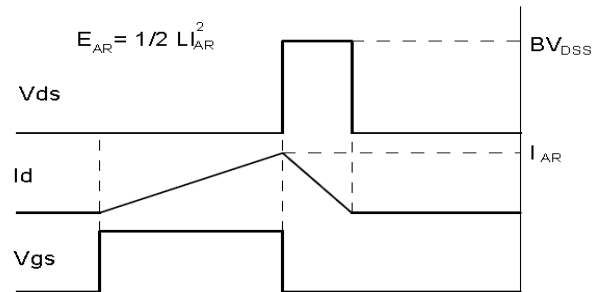
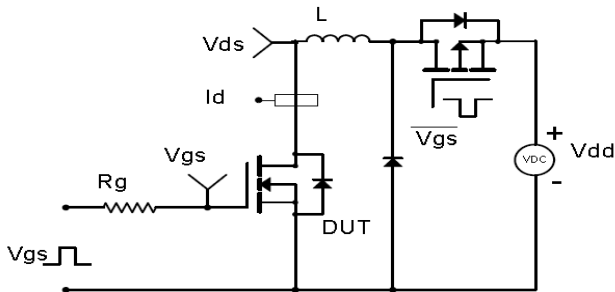
Gate Charge Test Circuit & Waveform



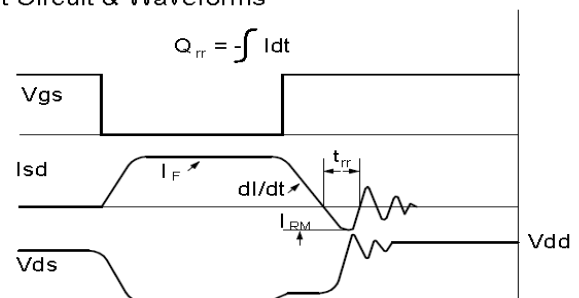
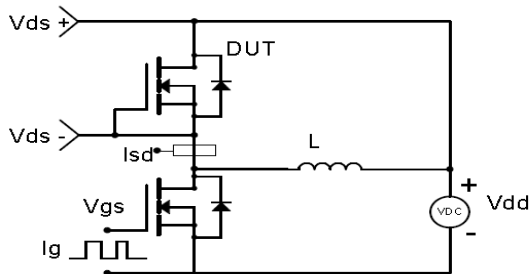
Resistive Switching Test Circuit & Waveforms



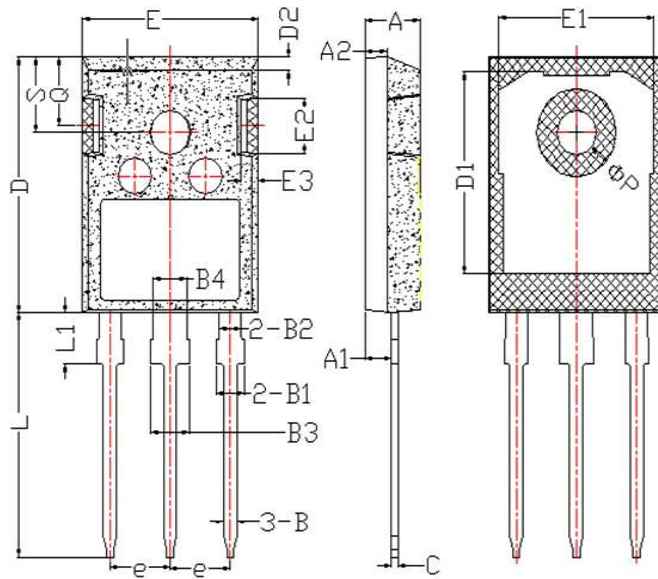
Unclamped Inductive Switching (UIS) Test Circuit & Waveforms



Diode Recovery Test Circuit & Waveforms



## Package Outline: TO-247



Items	Values(mm)	
	MIN	MAX
A	4.6	5.2
A1	2.2	2.6
B	0.9	1.4
B1	1.75	2.35
B2	1.75	2.15
B3	2.8	3.35
B4	2.8	3.15
C	0.5	0.7
D	20.6	21.3
D1	16	18
E	15.5	16.1
E1	13	14.7
E2	3.8	5.3
E3	0.8	2.6
e	5.2	5.2
L	19	20.5
L1	3.9	4.6
Φp	3.3	3.7
Q	5.2	6
S	5.8	6.6



## Revision History

Revision	Date	Major changes
1.0	2024/4/12	Release of formal version

## Disclaimer

Unless otherwise specified in the datasheet, the product is designed and qualified as a standard commercial product and is not intended for use in applications that require extraordinary levels of quality and reliability, such as automotive, aviation/aerospace and life-support devices or systems.

Any and all semiconductor products have certain probability to fail or malfunction, which may result in personal injury, death or property damage. Customer are solely responsible for providing adequate safe measures when design their systems.

CRM reserves the right to improve product design, function and reliability without notice.