

FERROXCUBE

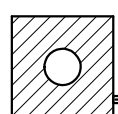

e

f

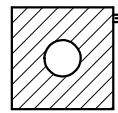
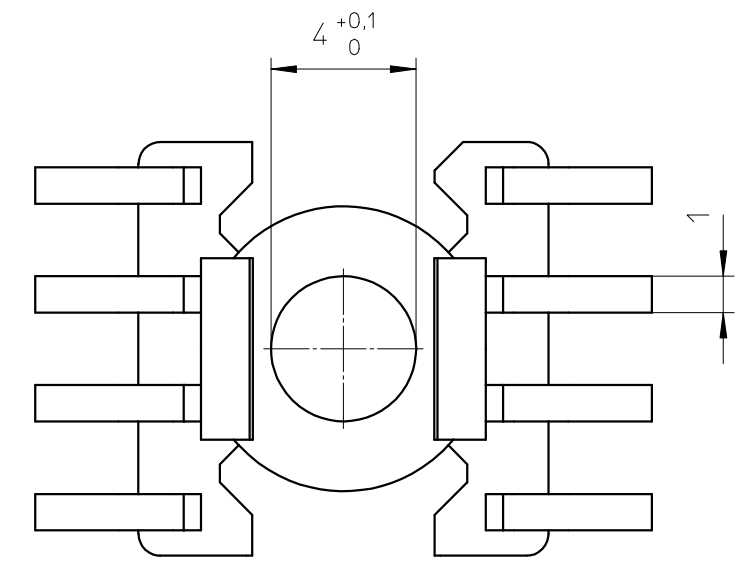
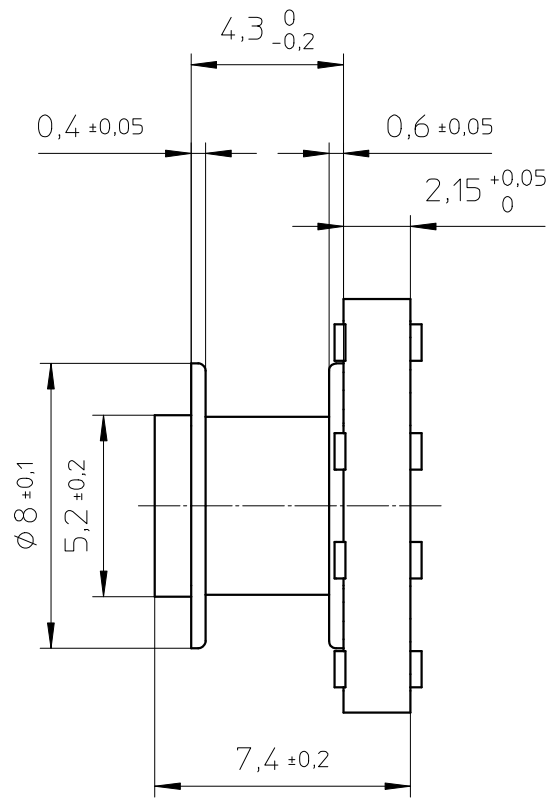
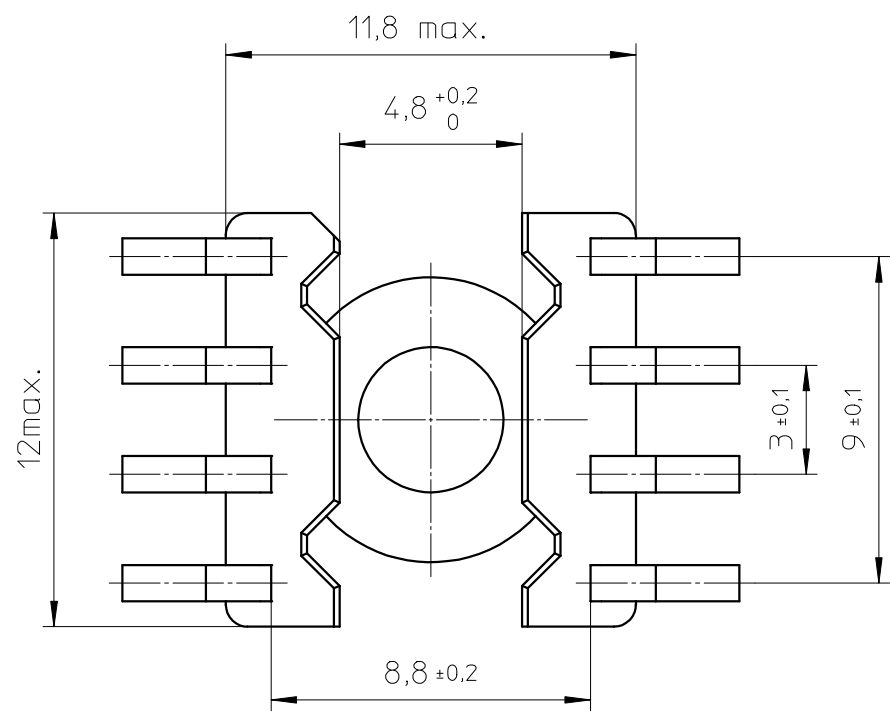
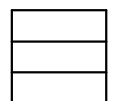

PROPOSED PAD ARRANGEMENT:

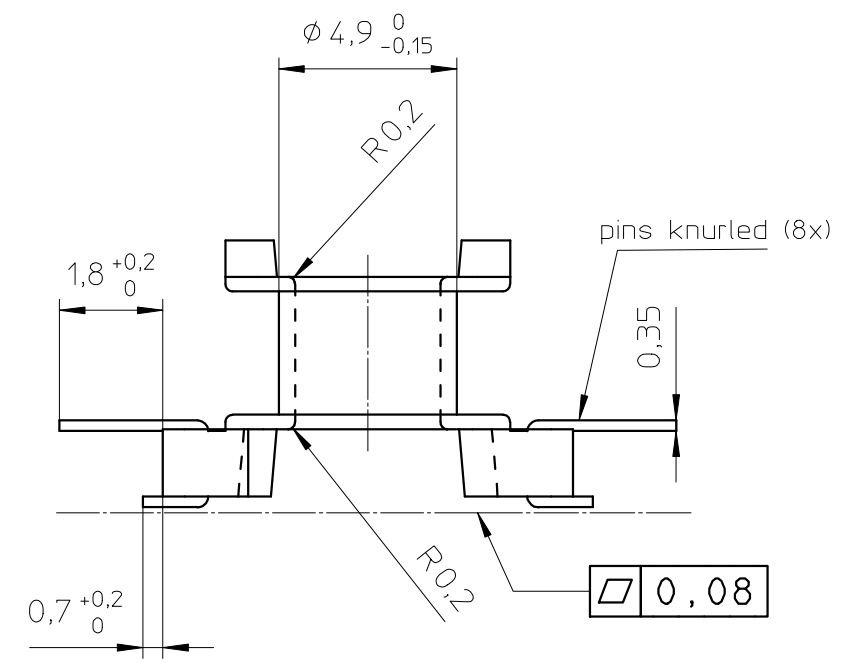
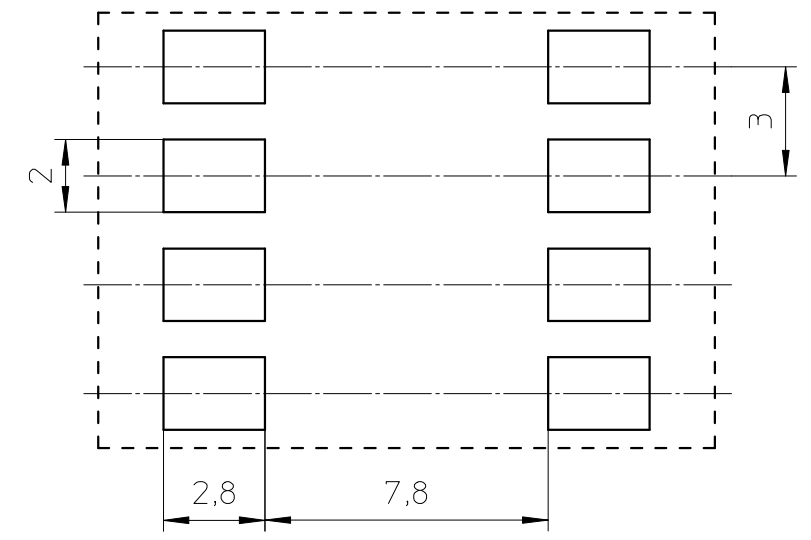

Coil former material: Sumikon PM9630 (PF), glass-reinforced.
 UL file number: E41429(M) - UL94V-0.
 Pin material: CuSn - Ni flash, Sn plated.
 Max. operating temp.: acc. to IEC 60 085 class F, 155°C.
 Resistance to soldering heat: acc. to IEC 60 068-2-20 Part 2, Test Tb, method 1B, 350°C - 3,5s.
 Solderability: acc. to IEC 60 068-2-20 Part 2, Test Ta, method 1, 235°C - 2s.

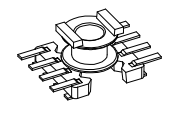

| | | | | | |
|--------------|---------------------|------------------|--------------------|-----------------------------|-------------------|
| CLASS.NO. | CSVS-RM4/LP-1S-8P-Z | | 4322 021 06551 | 06-07-14 | 06-07-20 |
| NAME NAAM | A.Wojtasz | SUPERS. VERY. | 001 SH SH BL BL | 112 - 001 | 069 |
| MPA | CHECK CONTR. | DAT. | 06-07-14 | Property of Eigendom van | © FERROXCUBE 2000 |