

TMCC02 High Voltage Ceramic Capacitor

Features:

- Low dissipation factor of 0.2% at 1 KHZ
- High frequency $\geq 550\text{KHZ}$
- High current $\geq 50\text{mA}$
- High voltage ≥ 1.5 times
- High insulation resistance $\geq 200000\text{M}\Omega$
- Long life ≥ 10 years

Application:

- High frequency & high voltage power supplies;
- CO2 lasers, high voltage pulse generator
- X-ray equipment
- NDT (Non-destructive testing)
- Airport security equipment
- Capacitance: 50PF~20000PF
- Voltage Class: 10KVDC~200KVDC

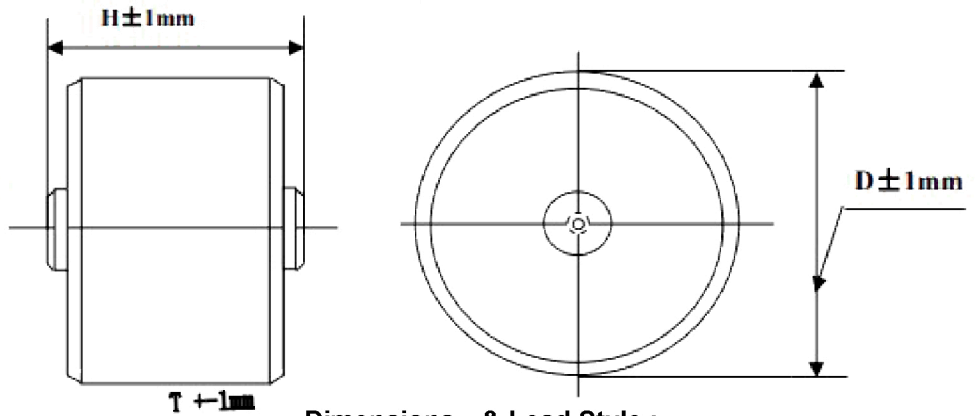

Dimensions & Lead Style :

Ceramic Dielectric Properties:

Ceramic Dielectric	Operating temperature Range(°C)	Insulation Resistance ($\geq \text{M}\Omega$)	Dissipation Factor \leq	Temperature characteristics
N4700(DL)	-25~+85 °C	200000	0.2%	+/-28%

Ordering Information

No.	Part Number	Ceramic Dielectric	Rated Voltage(KV)	Capacitance		Dimensions (mm)			
				C (pF)	Tol.(%)	D	T	H	Screw
1	TMCC02-501K50KVB	DL(N4700)	50	500	10	38	32	36	M5

About N4700 ceramic

N4700 ceramic capacitor is successfully developed in recent years, a new type of ceramic, a ceramic material widely used in high-end products, compared to other Class I ceramic dielectric constant large, suitable for larger capacitance, resistance higher voltage, dissipation factor less than 0.2%, much lower than the average class II ceramic; insulation resistance is greater than 200000MΩ, better frequency and characteristics of the temperature coefficient, withstand greater current, its temperature variation of capacitance is within $\pm 28\%$ from -25°C to +85°C, its life of more than 10 years.

Class I

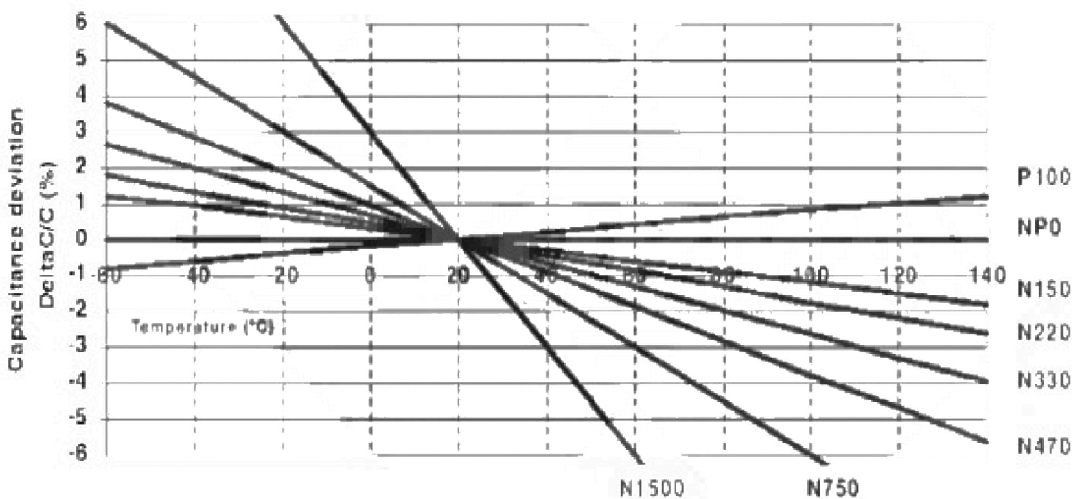

Precautions

- (1) During transportation and storage • Do not transport or store where the capacitor will be exposed to high temperature or high humidity. • Do not expose to poisonous gases such as H₂SO₄, HCL or HNO₃. • Avoid excessive impact such as that caused by falling.
- (2) During operation • Avoid contact with electrolytes such as perspiration. Do not touch with bare hands. • Avoid excessive impact such as that caused by falling. • Do not apply solder to stud terminals. • Do not re-machine the terminals.
- (3) Usage • When the capacitor is used for high-speed pulses such as with a laser, make sure that the impressed voltage (peak-to-peak volt-age) is within the capacitor's rated specifications. • Make sure that the capacitor is not exposed to radiant heat from cham.