

**LEPCOS (North-West Laboratory)**  
 http://ferrite.ru Tel/fax +7-812-369-11-54  
 St-Petersburg, Russia

REVISIONS

SYM	DRAFTER	CHECKER	DATE
	Joy.Liu	Mike.Wang	08/14/09

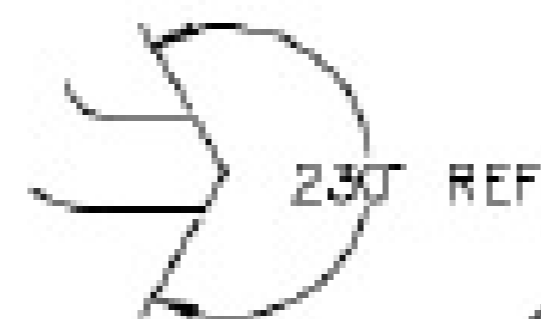
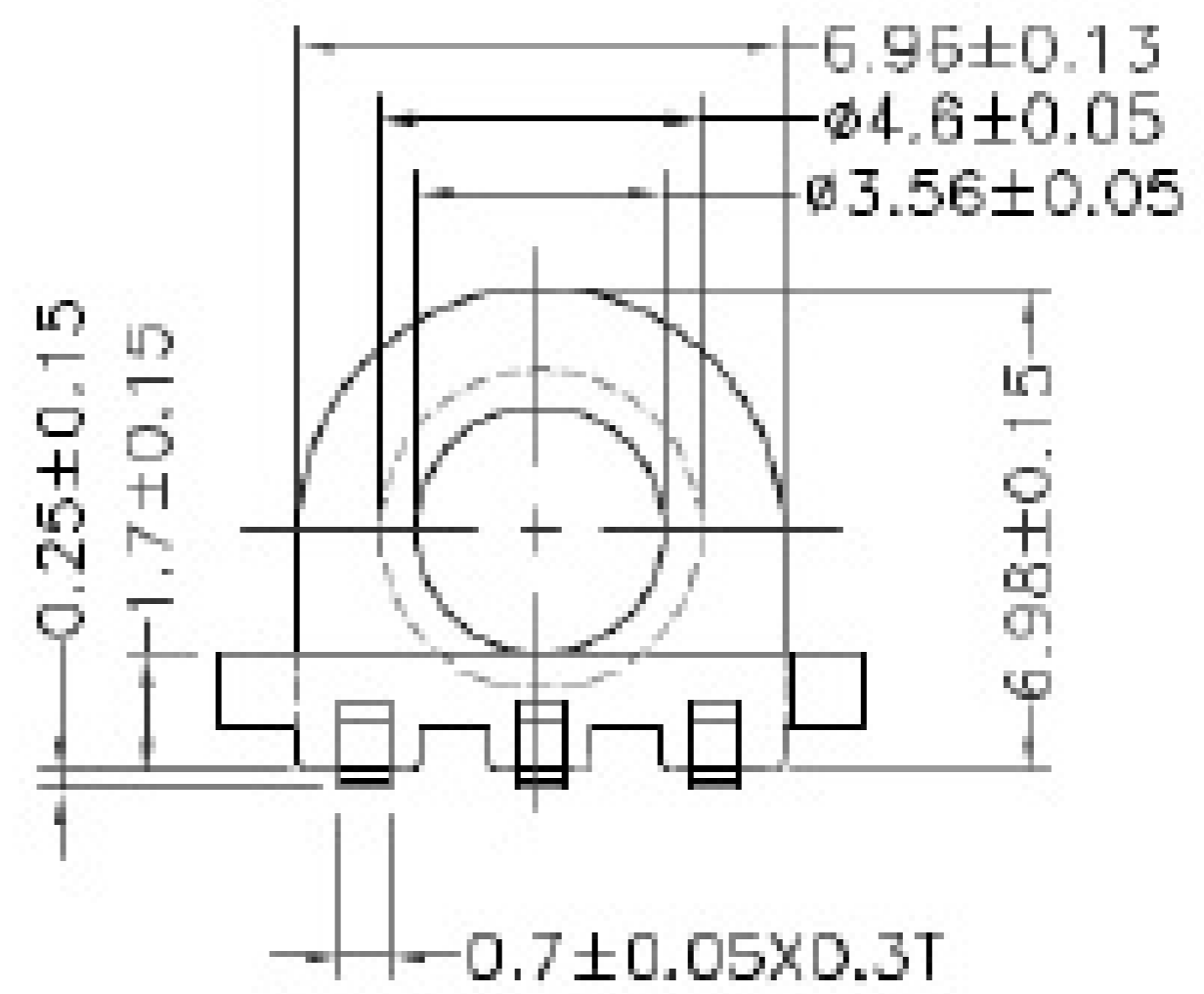
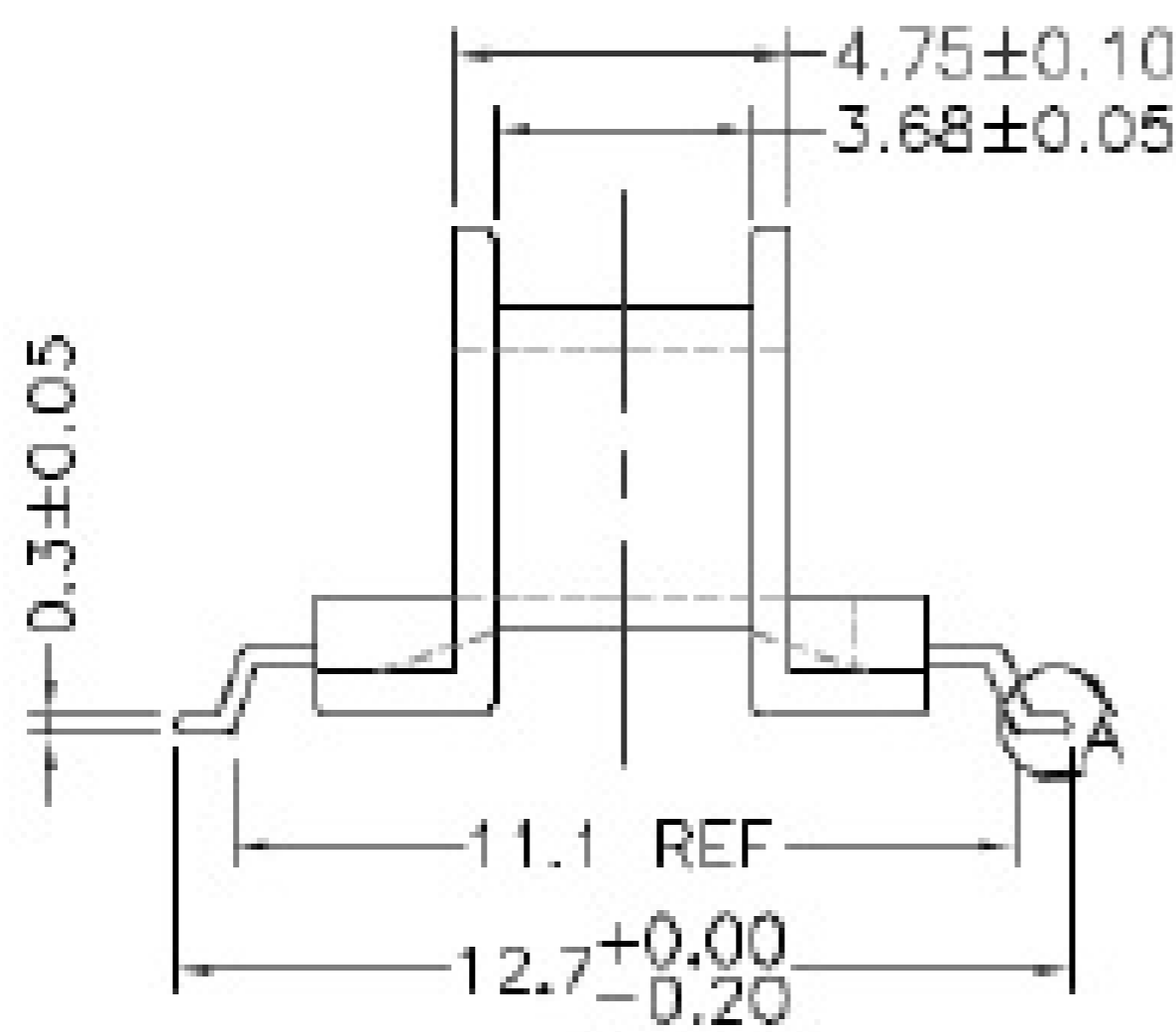
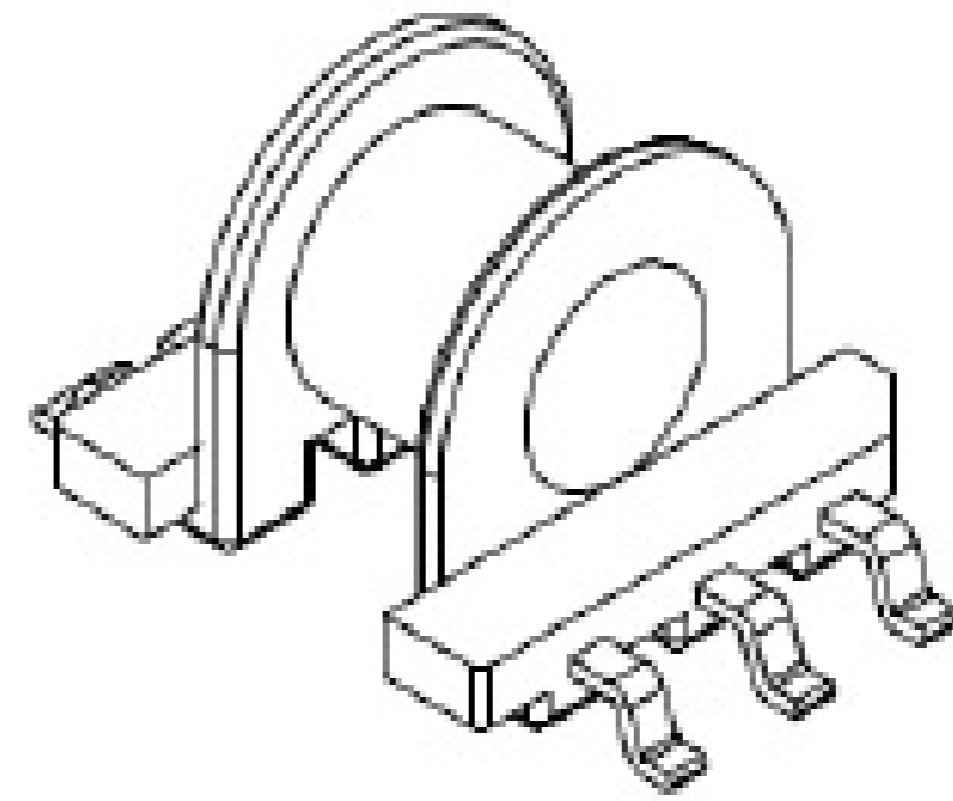
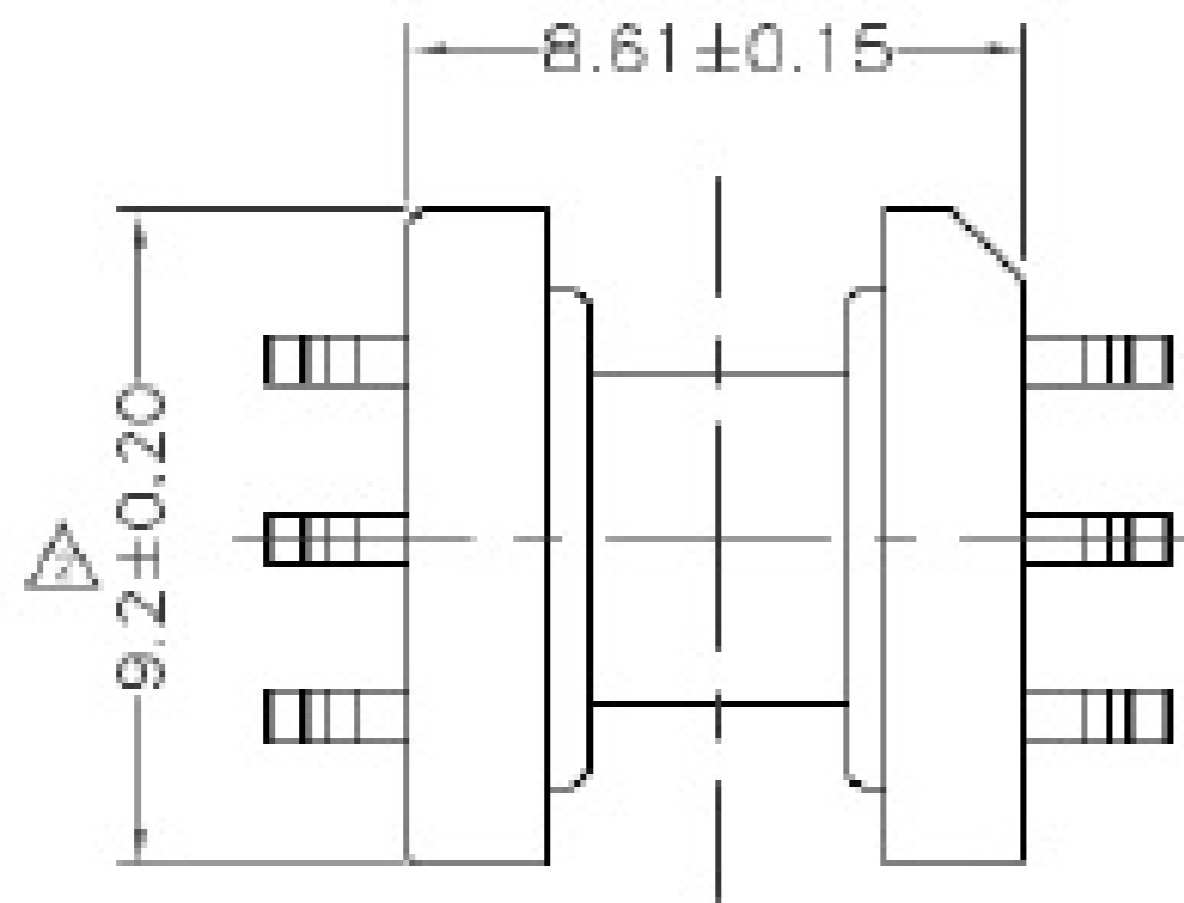

**DETAIL:A**  
**PATENTED**

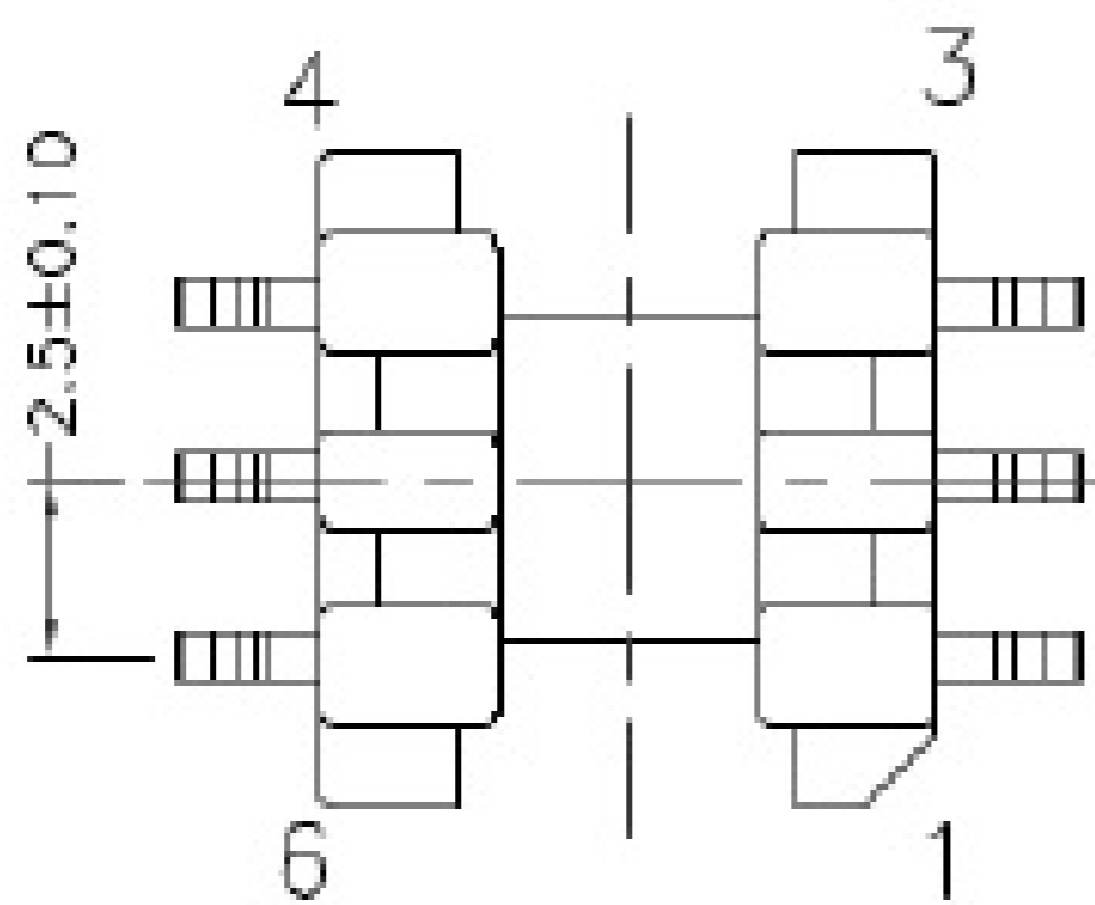
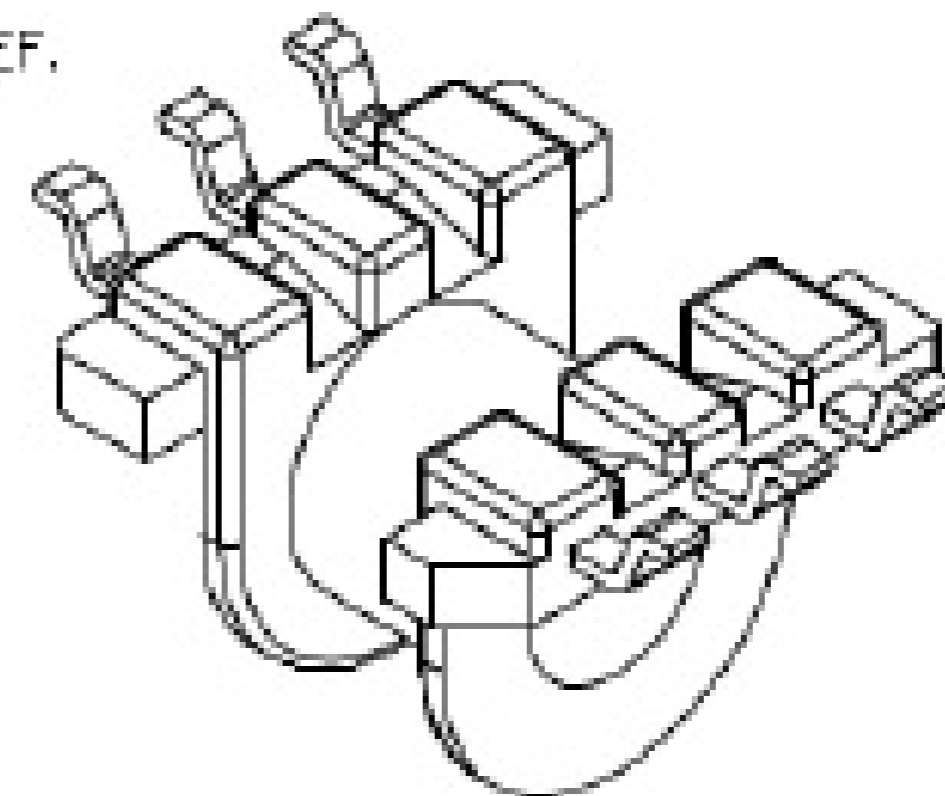

NOTE:  
 1 : pin (1.0 kg Min)

DWG NO. E-012 Bobbin EP-7 1 section 6 pin SMD

PART NO.	MATERIAL (BOBBIN)	MATERIAL (TERMINAL)	TERMINAL (PLATING)	PIN ALLOCATION	NOTE
WS-S089	PM-9630	P.B	Sn		
					H

TOLERANCE: X±0.15 XX±0.10 XXX±0.05 UNIT : m/m SCALE 4:1

Finish: 1. Pb wire Immersion Sn on terminal : Thickness:Sn plating, 100,5 μm (200 μ inches) min, Base nickel 0.625 μm (25 μ inches) min.  
 2. CP wire Immersion Sn on terminal : Thickness:Sn plating, 100,5 μm (200 μ inches) min.  
 3. Coplanarity deviation: 0.10 mm (0.004 inches) max.

REV **A**