

FERROXCUBE



c



d



e

f

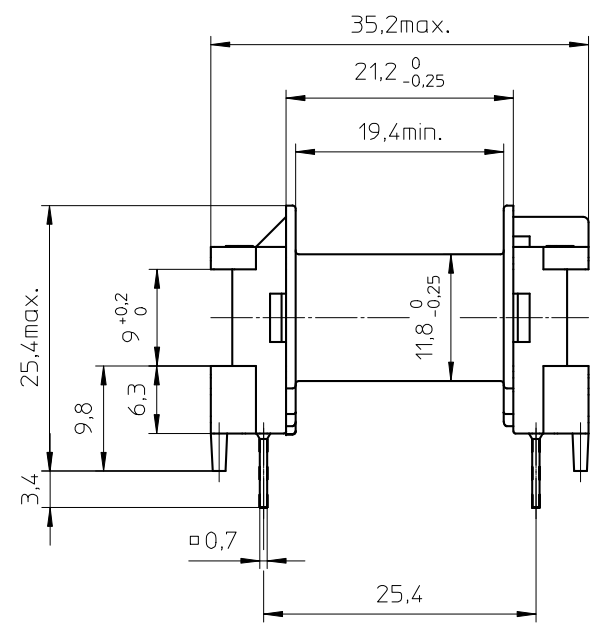
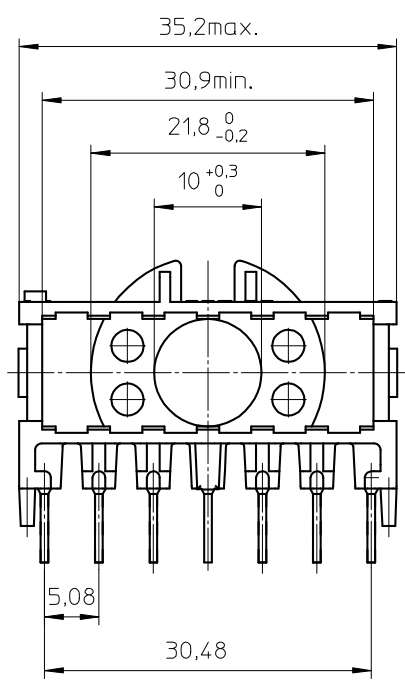

HOLE PATTERN:

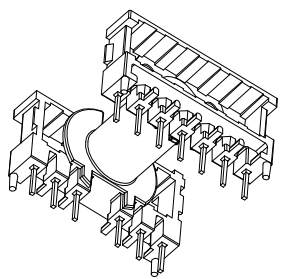
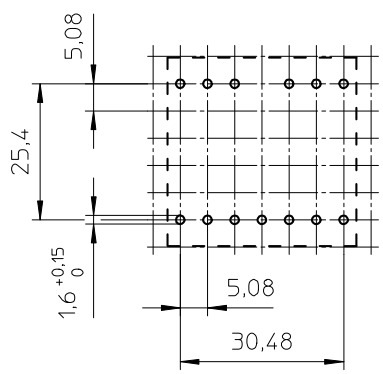

- Coil former material: Rynite FR 530 (PET), glass-reinforced.
UL file number: E41938 - UL94V-0.
- Pin material: CuSn - Ni flash, Sn plated.
- Max. operating temp.: acc. to IEC 60 085 class B, 130°C.
- Resistance to soldering heat: acc. to IEC 60 068-2-20 Part 2, Test Tb, method 1B, 350°C-3,5s.
- Solderability: acc. to IEC 60 068-2-20 Part 2, Test Ta, method 1, 235°C-2s.
- Min. winding area: 95 mm².
- Mean length of turn: 52 mm.

CLASSNO.		09-04-21	
09-04-21		CPH-ETD29-1S-13P-C	4322 021 07111
NAME NAAM	M. Tryngiel	SUPERS. VERV.	001
MPA	CHECK CONTR.	DAT.	Property of Eigenaam van
		SP/SH BL/BL	112 - 001
			069
			A3
© FERROXCUBE 2009			